

Electrical Power

W. J. R. H. Pooler



Download free books at

bookboon.com

W. J. R. H. Pooler

Electrical Power

Electrical Power

2nd Edition

© 2013 W. J. R. H. Pooler & Ventus Publishing ApS

ISBN 978-87-403-0145-8

Contents

Summary	6
Electromagnetism and Electrostatics	14
Induced EMF	24
DC Circuits	36
Alternating Current (AC)	40
Resistance, Inductance and Capacitance on AC	49
AC Circuits	55
Magnetic Properties of Materials	65
DC Motors and Generators	72
AC Synchronous Machines	100
AC Induction Motors	127
Insulation	132



www.sylvania.com

We do not reinvent
the wheel we reinvent
light.

Fascinating lighting offers an infinite spectrum of possibilities: Innovative technologies and new markets provide both opportunities and challenges. An environment in which your expertise is in high demand. Enjoy the supportive working atmosphere within our global group and benefit from international career paths. Implement sustainable ideas in close cooperation with other specialists and contribute to influencing our future. Come and join us in reinventing light every day.

Light is OSRAM

OSRAM
SYLVANIA



Transformers	133
Rectifiers	140
Power Lines	146
Neutral Earthing	148
Switchgear	150
Instruments	159
Protection	167
Power Systems	172
Generator Response to System Faults	177
Calculation of Fault Currents	195
Symmetrical Components	201
Commissioning Electrical Plant	209
Index	213



CHALLENGING PERSPECTIVES

Internship opportunities

EADS unites a leading aircraft manufacturer, the world's largest helicopter supplier, a global leader in space programmes and a worldwide leader in global security solutions and systems to form Europe's largest defence and aerospace group. More than 140,000 people work at Airbus, Astrium, Cassidian and Eurocopter, in 90 locations globally, to deliver some of the industry's most exciting projects.

An **EADS internship** offers the chance to use your theoretical knowledge and apply it first-hand to real situations and assignments during your studies. Given a high level of responsibility, plenty of learning and development opportunities, and all the support you need, you will tackle interesting challenges on state-of-the-art products.

We welcome more than 5,000 interns every year across disciplines ranging from engineering, IT, procurement and finance, to strategy, customer support, marketing and sales. Positions are available in France, Germany, Spain and the UK.

To find out more and apply, visit www.jobs.eads.com. You can also find out more on our **EADS Careers Facebook page**.

AIRBUS **ASTRIUM** **CASSIDIAN** **EUROCOPTER**

EADS



Summary

Units

cm/gm/sec (cgs) units are:

dyne = force to accelerate 1 gm at 1 cm/sec^2

erg = work done by 1 dyne cm

unit pole = magnetic pole that exerts 1 dyne on an identical pole 1 cm distant in a vacuum

G = gauss = magnetic field that exerts 1 dyne on a unit pole

maxwell (previously **lines**) = magnetic flux = magnetic flux of field of 1 gauss crossing 1 cm^2

emu of current = current flowing through an arc 1 cm radius, length 1 cm which causes a magnetic field of 1 gauss at the centre of the arc

Gilbert = magneto motive force (**mmf**) = magnetizing force due to an electric current

Oe = oersted = magnetizing force per cm length of the magnetic circuit. The symbol for magnetizing force per unit length is **H**.

Permeability is a property of a magnetic material. The symbol for permeability is μ .

In a vacuum, $\mu = 1$. In air, $\mu = \text{approx } 1$. For iron, μ can be over 1000 but is not a constant.

A magnetizing force of 1 Oe produces a magnetic field of μ gauss.

Engineering units are:

N = newton = force to accelerate 1 kg at $1 \text{ m/sec}^2 = 10^5$ dynes

J = joule = work done by 1 newton metre = 10^7 ergs

W = watt = 1 joule/ second = 10^7 ergs/sec

kW = kilowatt = 1000 watts

HP =horse power = 550 ft lbs/sec = 746 watts

I = amp = 1/10 of emu of current

T = tesla = magnetic field strength 10^4 gauss. The symbol for magnetic field is **B**

Wb = weber = magnetic flux = magnetic flux of magnetic field of 1 tesla crossing 1 m^2 .

The symbol for magnetic flux is Φ . $1 \text{ Wb} = 10^8$ maxwells.

Corkscrew Rule As current flows along a wire, the magnetic field rotates in the direction of a corkscrew.

Ampere turns = mmf. A coil N turns carrying a current I amps gives an mmf of N I ampere turns

In a vacuum, a magnetizing force of 1 ampere turn / metre produces a magnetic field of 1.26×10^{-6} tesla.

Magnetic field $B = \mu H$ where B is in tesla and $H = 1.26 \times 10^{-6}$ times ampere turns / metre

MMF in a solenoid, N turns and current I $\text{mmf} = (4 \pi / 10) N I$ Gilberts.

Magnetizing Force at the centre of a long solenoid $H = (4 \pi / 10) N I / L = 1.26 N I / L$ Oersteds

where L is the length in cm and (N I) is the ampere turns

Magnetic field at the centre of a long solenoid length L metres $B = 1.26 \mu N I 10^{-6} / L$ tesla.

In magnetic materials, μ is not a constant and the maximum useful value of B is about 1.5 Tesla

Magnetic flux $\Phi = B A$ where Φ is in weber, B is in tesla and A is in square metres.

Magnetic flux in a uniform closed magnetic circuit, length L metres and cross section A square metres is

$\Phi = 1.26 N I \mu A \times 10^{-6} / L$ weber.

Closed magnetic circuit eg a ring with an air gap or the field circuit of an electrical machine, mmf = sum of mmfs to drive same Φ in each part, hence

$$\Phi = 1.26 N I \times 10^{-6} / \Sigma(L_i/\mu_i A_i) \text{ Where } \Phi \text{ is in weber, } I \text{ in amps, } A \text{ in m}^2 \text{ and } L \text{ in metres.}$$

Force on a conductor in a magnetic field $F = B I L$ Newtons where B in tesla, I in amps and L in metres

Force on parallel conductors $F = [2 I^2 / d] 10^{-7}$ Newtons/metre where I is in amps and d is in metres

With currents in opposite directions, the force is pushing the conductors apart

Pull of Electromagnet $\text{Pull} = B^2 10^7 / (8 \pi)$ newtons per m² of magnet face where B is in tesla

Definition of Volts. The **potential difference** between two points is 1 **volt** if 1 watt of power is dissipated when 1 amp flows from one point to the other. $W = V I$

Ohms Law (for a direct current circuit with resistance R ohms) $V = I R$

Power loss in a resistor $W = I^2 R = V^2 / R$

Resistance $R = \rho L (1 + \alpha T) / A$ ohms where ρ is resistivity in ohms per cm cube, L cm is the length, A cm² is the cross sectional area, α is temp co-eff and T is the temperature in degrees Celsius.

Several sources give Copper $\rho = 1.7 \times 10^{-6}$ ohms per cm cube and $\alpha = 0.004$. At very low temperatures, the resistance of some materials falls to zero

Resistance R_1 in series with R_2 . Equivalent resistance = $R_1 + R_2$

Resistance R_1 in parallel with R_2 . Equivalent resistance = $1 / (1/R_1 + 1/R_2)$

Kirchoff's first law The total current leaving a point on an electrical circuit = total current entering

Kirchoff's second law The sum of the voltages round any circuit = net "I R" drop in the circuit

Induced emf $E = - N d\Phi/dt$ where E is in volts, N is number of turns and $d\Phi/dt$ is in Wb/sec

This equation is the foundation on which Electrical Engineering is based.

Self Inductance $E = - L dI/dt$ where E is in volts, L is inductance in henries and dI/dt is in amps/sec

Self inductance of a coil wound on a ring of permeability μ is $L = 1.26 N^2 \mu A / S \times 10^{-6}$ Henries

where N is number of turns, A is cross sectional area in m² and S metres is the length of the magnetic circuit. Experimental results for a coil length S metres, diameter d metres and radial thickness t metres with air core indicate $L = 3 d^2 N^2 / (1.2 d + 3.5 S + 4 t)$ micro Henries. (t = 0 for a single layer coil).

Energy stored in an inductance = $\frac{1}{2} L I^2$ Joules where L is in henries and I is in amps

Capacitance $q = C V$ where q is in Coulombs (ie amps times seconds), C is Farads and V is volts

Capacitance of a parallel plate condenser area A cm² and separated d cm and dielectric constant k

$$C = 1.11 \times 10^{-6} A k / (4 \pi d) \text{ microfarads}$$

Capacitance of co-axial cylinders radii a and b $C = 1.11 \times 10^{-6} k / [2 \ln(b/a)]$ microfarads per cm

Energy stored in a capacitance = $\frac{1}{2} C V^2$ Joules where C is in farads and V in volts

DC Motors and Generators

Motors obey the **left hand rule** and generators the **right hand rule**, (the gener - righter rule).

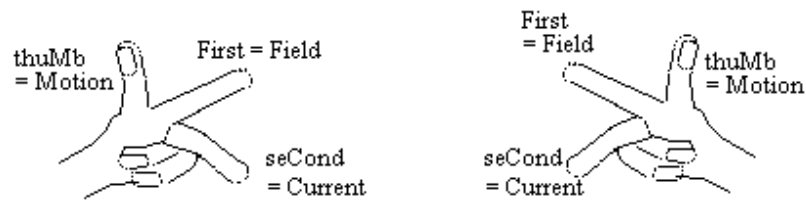

Back emf in DC machine $E = 2p Z_S \Phi rps$ where E is volts, 2p is number of poles, Z_S is number of conductors in series, Φ is in Wb and rps is speed in rev/sec

Power $W = 2p Z_S \Phi I_a rps$ where W is watts, I_a is the armature current in amps

Torque $Torque = 2p Z_S \Phi I_a / (2 \pi)$ Newton metres = $E I_a / (2 \pi rps)$ Newton metres

In Imperial units $Torque = 0.117 \times 2p Z_S \Phi I_a$ lb ft = $0.117 E I_a / (rps)$ lb ft)

Shunt motor $n = n_0 - m T$ where n is speed, n_0 is no load speed, m is approximately constant and T is Torque. $n_0 = V / (2p \Phi Z_S)$ and $m = 2 \pi R_a / (2p \Phi Z_S)^2$

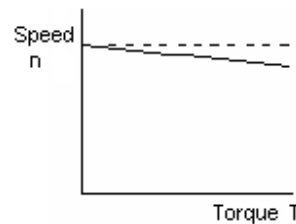
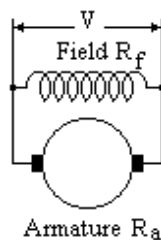

Series motor $T = T_0 / (1 + \alpha n)^2$ where T_0 and α are approximately constant

$T_0 = 2p K Z_S V^2 / (2 \pi R^2)$ and $\alpha = 2p K Z_S / R^2$ and $K = \Phi / I = 4 \pi N \times 10^{-7} / \Sigma(L / \mu A)$

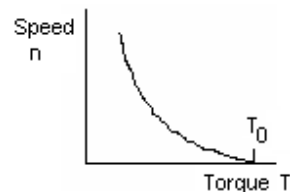
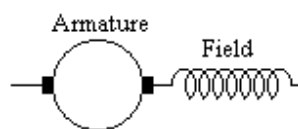

Compound motor has shunt and series windings. This can increase the starting torque for a shunt motor. If wound in opposition, the motor speed can be made nearly constant.

Armature reaction causes a magnetizing force centred between the poles distorting the field and slightly reducing it. **Compensating windings** between the main poles cancel the armature reaction.

Interpoles are small poles carrying armature current between the main poles to improve commutation.

Armature windings can be **lap** or **wave** wound.

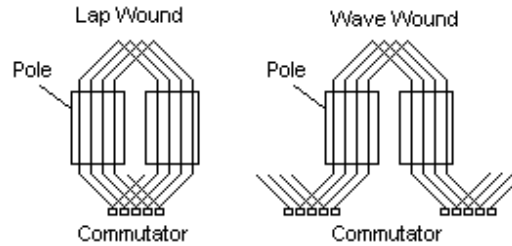

DC shunt generators will fail to excite if there is no residual magnetism or the field resistance is above the critical value for the speed.

DC series or compound generators require special treatment especially when two or more are in parallel.

Alternating Current AC

AC emf $E = E_p \sin(\omega t) = E_p \sin(2\pi ft)$ where E_p is peak value, f is frequency and t is seconds. **Mean value** of E for a half cycle = $2 E_p / \pi = 0.636 E_p$.

Root mean square (rms) value = $E_p / \sqrt{2} = 0.707 E_p$

peak factor = (peak value) / (rms value).

form factor = (rms value) / (average value for 1/2 cycle)

Square wave peak factor = 1, form factor = 1 Sine wave peak factor = 1.41, form factor = 1.11

Triangular wave peak factor = 1.73, form factor = 1.15

Vector representation of AC voltage and current.

The projection on a vertical surface of a vector rotating at constant speed anti clockwise is equal to the value of an AC voltage or current. The phase angle between V and I is the same as the angle between their vectors. The diagram shows the Vector representation of current and voltage where the current lags the voltage This diagram shows the vectors as the peak values. However the rms values are 0.707 times the peak value. Thus the vector diagram shows the rms values to a different scale. Vector diagrams are rms values unless stated otherwise.

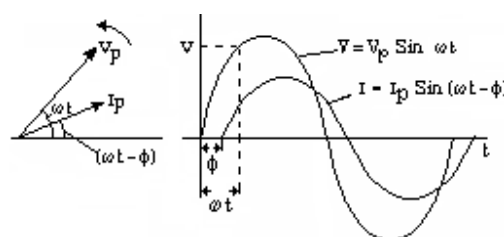

Power Factor is $\cos \phi$ where ϕ is the angle between the vectors for V and I

Power in a single phase AC circuit $W = V I \cos \phi$ watts

Three phase ac. Three voltages with phase angles of 120 degrees between each.

Power in a three phase AC circuit $W = \sqrt{3} V I \cos \phi$ watts where V is the voltage between lines

Resistance is higher on AC due to eddy current loss.

$R_f = R_0 [1 + 100 \pi^4 f^2 a^4 / (3 \rho^2)]$ where R_f and R_0 are the AC and DC resistances, f is the frequency, a is the radius of the conductor in metres and ρ is the resistance in microhms / cm cube.

$V = I R$ and the voltage V is in phase with the current I .

Inductance $V = I X_L$ where $X_L = 2 \pi f L$ where L is in Henries. I lags V by $\pi/2$.

At 50 cps, $X_L = 314 L$

Capacitance $V = I X_C$ where $X_C = 1/(2 \pi f C)$ where C is in farads. I leads V by $\pi/2$.

At 50 cps $X_C = 3183/C$ where C is in micro farads.

Inductive Impedance $Z = R + jX$. $V = I \sqrt{(R^2 + X^2)}$ I lags V by $\arctan(X/R)$

Capacitive Impedance $Z = R + jX$. $V = I \sqrt{(R^2 + X^2)}$ I leads V by $\arctan(X/R)$

Impedance $R_1 + jX_1$ in series with $R_2 + jX_2$ Equivalent impedance = $(R_1 + R_2) + j(X_1 + X_2)$

Impedance $R_1 + jX_1$ in parallel with $R_2 + jX_2$ Put X +ive for inductance, -ive for capacitance
Put $Z_1 = \sqrt{(R_1^2 + X_1^2)}$ and $Z_2 = \sqrt{(R_2^2 + X_2^2)}$ Put $A = R_1/Z_1^2 + R_2/Z_2^2$ and $B = X_1/Z_1^2 + X_2/Z_2^2$
Equivalent impedance is $R = A / (A^2 + B^2)$ and $X = B / (A^2 + B^2)$

Sum of two AC currents.

Add I_1 at phase angle θ_1 to current I_2 at phase angle θ_2 and the result is I_3 at phase angle θ_3

I_3 and θ_3 are obtained by the vector addition of I_1 and I_2 .

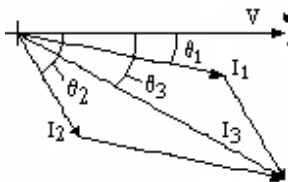

Hysteresis loss $\text{Loss} = f(\text{area of hysteresis loop})$ watts/cubic metre where the hysteresis loop is in tesla and ampere turns/ metre

Energy in magnetic field $\text{Energy} = B^2 10^7 / (8 \pi)$ joules per cubic metre where B is in tesla

Eddy current loss in laminated core $\text{Loss} = \pi^2 f^2 B_M^2 b^2 / (6 \rho)$ watts per cm^3

Where $B = B_M \sin(2\pi f t)$ is parallel to the lamination, f is the frequency in Hz, b is the thickness in cm of the lamination and ρ is the resistivity in ohms/ cm cube.

Star/Delta transformation

Three impedances $R + jX$ in star = three impedances $3R + 3jX$ in Delta

AC generators and motors

Fundamental EMF of generator $E_{\text{RMS}} = 4.44 k_p k_D N f \Phi_{\text{TOTAL}}$

where N is (number of turns) / (pairs of poles) and k_p is the pitch factor. If each coil spans an angle of 2λ instead of the full angle π between the poles, then $k_p = \sin(\lambda)$. k_D is the distribution factor due to the phase difference of the emf in each conductor. $k_D = (\text{vector sum of emfs}) / (\text{scalar sum of emfs})$

For N^{th} harmonic, $k_{\text{NP}} = \sin(n\lambda)$, and $k_{\text{ND}} = \sin(n\theta/2) / [c \sin(n\theta/2c)]$ where $\theta = \pi / (\text{no of phases})$ and $c = \text{slots / phase / pole}$. Harmonic content can be kept small by suitable values for λ , θ and c .

The third harmonic is blocked by a delta star transformer and can be ignored.

Armature reaction of a current in phase with V gives an mmf between the poles distorting the field.

Armature reaction of lagging currents give an mmf opposing the main field.

Armature reaction of leading currents give an mmf boosting the main field.



360°
thinking.

Discover the truth at www.deloitte.ca/careers

Deloitte.
© Deloitte & Touche LLP and affiliated entities.

Vector Diagram of the emfs, current and mmfs of a synchronous generator.

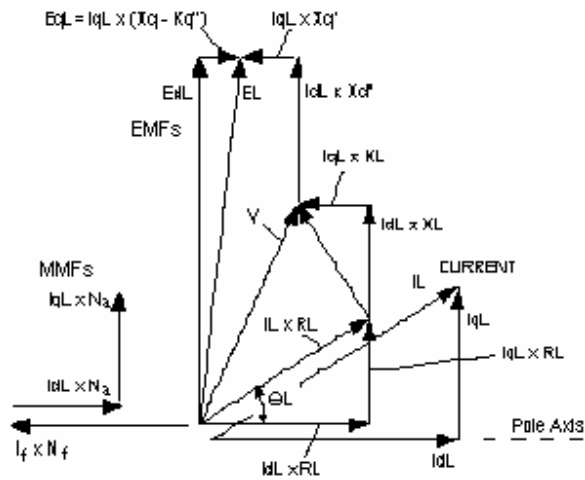

magnitude of E_{dL}
= magnitude of E_L

Suffix L signifies on load condition

Automatic Voltage Regulator adjusts the excitation so that at the system design power factor, the voltage is correct whatever the current. If however it adjusts the excitation to give the correct voltage at other power factors, then two machines will not run in parallel. One can supply a huge leading current and the other a huge lagging current. A “droop” is needed to give a lower voltage if the power factor lags by more than the system design. This is achieved by the **compounding**. Faulty Compounding causes unstable sharing of kVAr which can be quite violent.

System Faults. When a fault occurs, initially dc currents are induced in the damping winding and main field circuit opposing the demagnetizing effect of the low power factor fault current. These currents die away exponentially causing the fault current to fall. In extreme cases it can fall below the full load value.

Induction motor Power = $3 V^2 (1 - \Sigma) R_r \Sigma / (R_r^2 + X^2 \Sigma^2)$ watts where the slip $\Sigma = (n_0 - n) / n_0$

Power = $2 \pi T (1 - \Sigma) n_0$ watts where T is the torque in Newton metres and n_0 is the synch speed

Torque = $3 V^2 R_r \Sigma / [2 \pi n_0 (R_r^2 + X^2 \Sigma^2)]$ Torque is a maximum when $\Sigma = R_r / X$

Put $\Sigma = 1$, **Starting Torque** = $3 V^2 R_r / [2 \pi n_0 (R_r^2 + X^2)]$

If $R_r = X$, the maximum torque occurs when the speed is zero but the motor would be very inefficient.

However large motors sometimes have slip rings allowing an external resistance to be added for starting.

The Induction motor speed torque curve. Sometimes there is a kink in the curve at a speed below the speed for maximum torque due to harmonics in the supply. In such cases, the motor may get stuck at this speed, called “crawling”.

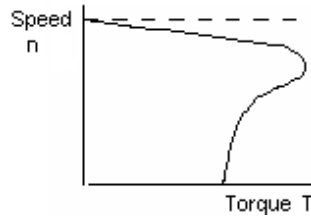

Transformers

Power transformers are usually delta primary and star secondary. The primary is supplied through three conductors.

Flux $\Phi_{max} = [4 \pi \mu A N I_{max} / L] \times 10^{-7}$ weber

EMF $E_{rms} = 4.44 N \Phi_{max} f$ volts

Delta Star Transformation

Three phase load, primary current equals secondary current times voltage ratio.

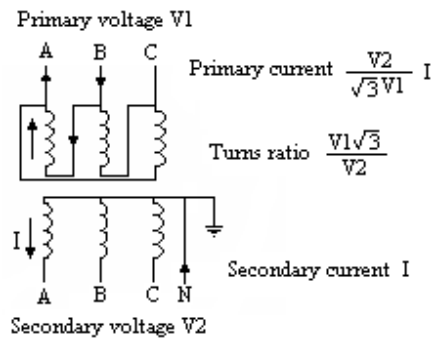

A single phase load on the secondary results in a current on two lines in the primary governed by the turns ratio, not the voltage ratio.

Third harmonic voltages are the same at each end of each primary winding. Therefore no third harmonic current flows in the primary and no third harmonic voltage appears in the secondary.

Electromagnetism and Electrostatics

Magnets, Magnetic Fields and Direct Currents

Units of Force, Work and Power

cm/gm/sec (cgs) units are

dyne = force to accelerate 1 gm at 1 cm/sec²

erg = work done by 1 dyne cm

Engineering units are

newton = force to accelerate 1 kg at 1 m/sec²

= 10⁵ dynes

joule = work done by 1 newton metre = 10⁷ ergs

watt = 1 joule/ second = 10⁷ ergs/sec

kilowatt = 1000 watts

horse power = 550 ft lbs/sec = 746 watts

The symbol “.” or a space will be used to signify “multiplied by”.

The symbol “•” signifies vector dot product.

Magnet

A magnet has two poles, a North pole and a South pole. When suspended, the North pole aligns towards the North and the South pole towards the South.

SIMPLY CLEVER

ŠKODA

We will turn your CV into
an opportunity of a lifetime



Do you like cars? Would you like to be a part of a successful brand?
We will appreciate and reward both your enthusiasm and talent.
Send us your CV. You will be surprised where it can take you.

Send us your CV on
www.employerforlife.com

Unit Pole

The pole of a magnet, whose strength is one **unit pole**, placed in a vacuum one cm from an identical pole repels it with a force of one dyne. At a distance r cm, they repel with a force of $1/r^2$ dynes.

Magnetic Field

The magnetic field at any point is the force on a unit North pole placed at that point, provided it does not disturb the magnetic field. The symbol used for magnetic field is **B**. It is a vector quantity. The cgs unit is dynes/unit pole or **gauss** (G). The Engineering unit is the **tesla** (T) = 10^4 gauss.

$$(\text{value in tesla}) = 10^{-4} \cdot (\text{value in gauss}).$$

Iron filings sprinkled on a card placed over the magnet align into lines from the North to the South pole and show the direction of the magnetic field.

Magnetic Flux

The magnetic flux crossing an area normal to a magnetic field is the product of the magnetic field and the area. The symbol used for magnetic flux is Φ . The cgs unit is the **maxwell** (previously **lines**) = gauss cm^2 . The Engineering unit is the **weber** (Wb) = tesla m^2 .

$$1 \text{ weber} = 10^8 \text{ maxwells}.$$

$$(\text{value in weber}) = 10^{-8} \cdot (\text{value in maxwells}).$$

$$\text{Flux } \Phi = \int \mathbf{B} \cdot d\mathbf{A} \quad \text{where B is in Tesla and A is } \text{m}^2$$

Magnetic Field due to an Electrical Current

Faraday was carrying out experiments in his laboratory with an electrical cell. There happened to be a magnetic compass on his table. He noticed that the compass needle was deflected whenever he switched on the electrical current. He investigated further and found that the current caused a magnetic field in a circular path round the wire. The direction of the magnetic field is in the clockwise direction when viewed in the direction of the current which flows from the positive to the negative terminal of the cell.

This is the **Corkscrew Rule**. As the corkscrew is wound forward in the direction of the current, it rotates in the direction of the magnetic field.

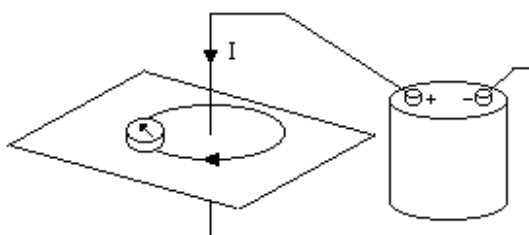
Magnetizing Force

The current produces a magnetizing force which is proportional to the current and inversely proportional to the square of its distance from the wire. The symbol for magnetizing force is **H** and the emu unit is the **oersted** (Oe). In a vacuum, a magnetizing force of one Oe produces a magnetic field of one G.

In a medium with permeability μ , one Oe produces a magnetic field of μ G.

The value of μ in a vacuum is 1 and in air is very close to 1.

For small values of H, μ for iron is approximately constant with a value in the order of 1000 or more.

$$\mathbf{B} = \mu \cdot \mathbf{H} \text{ provided H is small.}$$

However the relation between B and H in iron is not linear. Above about 1.5 tesla, the gradient falls dramatically. Thus magnetic circuits are often designed for a maximum B of about 1.5 tesla.

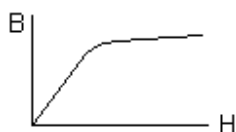

Furthermore, iron retains some magnetism when the magnetizing force is switched off. The magnetic field B therefore depends on both H and what has gone before.

Electromagnetic unit of current, Ampère’s or La Places’ Rule

Electrical current, strength one electromagnetic unit (1 emu), flowing through an arc of wire one cm long and one cm radius produces a magnetizing force of one oersted at the centre.

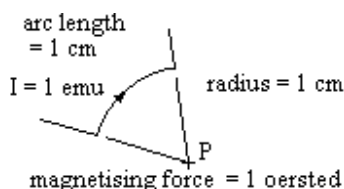

The symbol for current is **I**

The Engineering unit is the ampère or **amp**.

1 amp = 1/10 em unit of current.
 (value in amps) = 10 · (value in emu)

Quantity of Electricity

The emu for quantity of electricity is the quantity of electricity that crosses a cross section of the wire carrying 1 emu of current for 1 second.

The symbol for quantity of electricity is **q** and the Engineering unit is the **coulomb**.

1 coulomb = 1 amp second = 1/10 emu of quantity.
 $I = dq/dt$ where I is in amps, q is in coulombs and t is in seconds

Magnetizing force due to an element

The magnetizing force at P due to I emu of current through the element δs is;

$$\delta H = I \cdot \delta s \cdot \sin \theta / r^2$$

where H is in oersted, I is in emu, δs and r are in cm.



Mechanical Force on a conductor in a magnetic field

Place two unit poles P and Q a distance r cm apart in air ($\mu = 1$).

Pole P exerts a force of $1/r^2$ dynes on pole Q in the direction shown.

By the definition of magnetic field, the field at Q due to P is $1/r^2$ gauss.

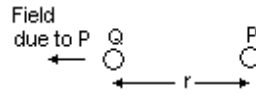

Replace pole Q by a length of wire δs long at an angle θ to the direction of P. The magnetic field at Q due to pole P remains at $1/r^2$ gauss.

Pass a current of I emu through the wire and it will cause a magnetic field of $I \cdot \delta s \cdot \sin \theta / r^2$ gauss at P
 By the definition of magnetic field, the element of wire exerts a force of $I \cdot \delta s \cdot \sin \theta / r^2$ dynes on pole P.
 By the corkscrew law the direction of the force is into the paper.

Action and reaction are equal and opposite, therefore the magnetic field of $1/r^2$ gauss due to pole P exerts a force of $I \cdot \delta s \cdot \sin \theta / r^2$ dynes on the element of wire.

Therefore a field of B gauss would exert a force of $B \cdot I \cdot \delta s \cdot \sin \theta$ dynes on the element of wire, the force being in a direction out of the paper.

I joined MITAS because
I wanted **real responsibility**

The Graduate Programme
for Engineers and Geoscientists
www.discovermitas.com

Month 16
I was a construction supervisor in the North Sea advising and helping foremen solve problems

Real work
International opportunities
Three work placements



In a uniform field of B gauss, a length of wire L cm long at right angles to the field and carrying a current of I emu will experience a force $F = B \cdot I \cdot L$ dynes in a direction complying with the left hand rule.

Converting to Engineering units,

$$F = B \cdot I \cdot L \text{ newtons}$$

where B is in tesla, I is in amps and L is in metres.

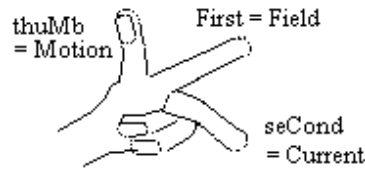

In diagrams, the direction of a vector into or out of the paper can be represented as a circle containing the tail or the point of an arrow.



The magnetizing force at the centre of a circle of wire radius R carrying a current I

$$H = 2 \cdot \pi \cdot r \cdot I / r^2 = 2 \cdot \pi \cdot I / r$$

where H is in oersted, I is in em units and r is in cms.

Magnetic field at the centre

$$B = (2 \cdot \pi \cdot \mu \cdot I / r) 10^{-7}$$

where B is in tesla, I is in amps and r is in metres.

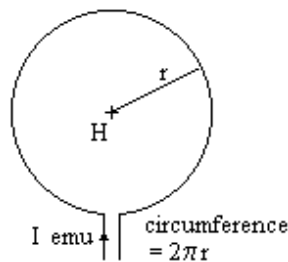

The magnetizing force at a point P distant x cm from a long straight wire carrying a current I emu

$$\delta H = I \cdot \delta s \cdot \sin \theta / r^2$$

But $r \cdot \delta \theta = \delta s \cdot \sin \theta$ and $x = r \cdot \sin \theta$

$$\delta H = I \cdot r \cdot \delta \theta / r^2 = I \cdot \delta \theta / r$$

$$= I \cdot \sin \theta \cdot \delta \theta / x$$

Integrate from 0 to π

$$H = \int (I \cdot \sin \theta / x) \delta \theta = (I/x) (-\cos \pi + \cos 0)$$

$$H = 2 \cdot I / x \text{ where H is in oersted, I is in em units and x is in cm.}$$

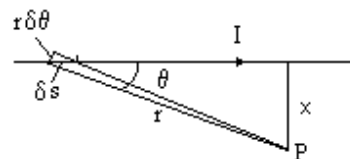

Let the conductor be radius a

Consider the magnetizing force in a circular element radius x cms and thickness δx within the conductor.

The current within this element is $I \pi x^2 / (\pi a^2)$ emu units

Therefore $H = 2 \cdot I x / a^2$ oersted

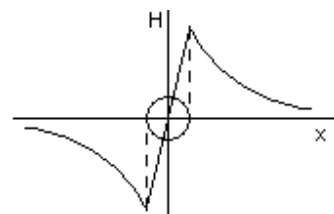

Thus the magnetic field a distance x metres from the centre of a conductor carrying I amps is given by;

Magnetic field within the conductor $B = (2 \cdot I \cdot \mu \cdot x / a^2) \cdot 10^{-7}$ tesla

Magnetic field outside the conductor $B = (2 \cdot I \cdot \mu / x) \cdot 10^{-7}$ tesla

Where $\mu = 1$ for air or non magnetic materials.

The force between two adjacent conductors

Two conductors lie parallel and d metres apart in air each carrying a current I amps in opposite directions.

Magnetic force at P due to left hand conductor

$B = (2 \cdot I / d) \times 10^{-7}$ tesla into the paper (corkscrew rule)

Mechanical force on δs at $P = B \cdot I \cdot \delta s$ newtons

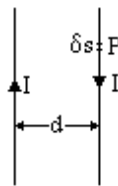

Mechanical force = $[2 \cdot I^2 / d] \cdot 10^{-7}$ newtons/metre

where I is in amps and d is in metres. The force is pushing the conductors apart (left hand rule).

Example

Two conductors are 2 cm apart and each carries a current of 400 amps in opposite directions. Find the force each exerts on the other.

The Force is $[2 \times 400^2 / (2 \times 10^{-2})] \times 10^{-7} = 400^2 \times 10^{-5} = 1.6$ newtons / metre

The magnetizing force at a point on the axis of a circle of wire carrying a current I em units

$$\delta H = I \cdot \delta s / d^2$$

Component along axis

$$\delta H \cdot \sin \theta = I \cdot \delta s \cdot \sin \theta / d^2$$

$$H = 2\pi \cdot I \cdot r \cdot \sin \theta / d^2$$

$$= 2\pi \cdot I \cdot \sin^3 \theta / r$$

By symmetry, the sum of the components of H perpendicular to the axis is zero

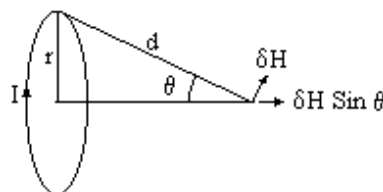

Magnetic field due to I ,

$B = [2\pi \mu I \sin^3 \theta / r] 10^{-7}$ where B is in tesla, I is in amps and r is in metres.

The magnetizing force on the axis of a solenoid

N turns uniformly wound

N δx /L turns in element δx

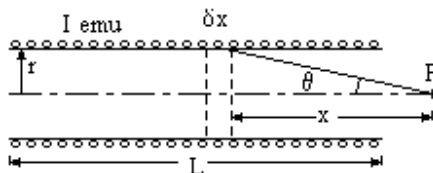

Magnetizing force at P due to element δx

$$\delta H = 2 \pi I \sin^3 \theta N \delta x / (L r)$$

But $x = r \cot \theta$

$$\delta x = -r \operatorname{Cosec}^2 \theta \delta \theta$$

$$\delta H = -2 \pi I \sin^3 \theta N r \operatorname{Cosec}^2 \theta \delta \theta / (L r)$$

$$\delta H = -(2 \pi I N / L) \sin \theta \delta \theta$$

$$H = \int [-(2 \pi I N / L) \sin \theta] \delta \theta \text{ from } \theta_1 \text{ to } \theta_2$$

$$= (2 \pi I N / L) (\cos \theta_2 - \cos \theta_1)$$

If P is at the centre of the solenoid,

$$\theta_2 = \phi \text{ and } \theta_1 = \pi - \phi$$

$$H = (4 \pi I N \cos \phi) / L$$

“I studied English for 16 years but...
...I finally learned to speak it in just six lessons”

Jane, Chinese architect

ENGLISH OUT THERE

Click to hear me talking before and after my unique course download



If the solenoid is very long, then $\cos \phi = 1$

$$H = (4 \pi / 10) I N / L$$

= 1.26 I N / L where H is in oersted, I is in amps and L is in cm

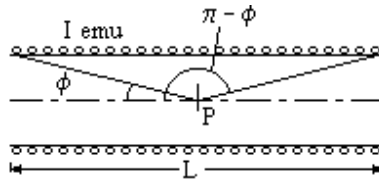

Magneto Motive Force

The current in a coil is said to produce a Magneto Motive Force (mmf) of $(4 \pi / 10) \times$ (Ampere Turns) **Gilberts**. Thus one Gilbert / cm produces a Magnetizing Force of one oersted. The symbol for mmf is **F**.

$$F = (4 \pi / 10) \times (\text{Ampere Turns}) \text{ where } F \text{ is in Gilberts}$$

Magnetic field (or Flux density) at the centre of a solenoid

$$B = 1.26 \mu I \text{ (N/L) gauss}$$

where B is in gauss, I is in amps and L is in cms

$$B = 1.26 \mu I \text{ (N/L) } 10^{-6} \text{ tesla}$$

where B is in tesla, I is in amps and L in metres

Magnetic Circuit

If the solenoid is wound on a ring, the magnetic circuit is complete within the ring.

The mmf $F = (4 \pi / 10) N I$ Gilberts

This causes flux $\Phi = (\mu F A / L) 10^{-6}$ weber

Where F is in Gilberts, A in m^2 and L in metres

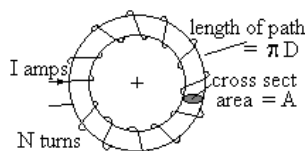

If the magnetic circuit consists of different materials, eg a ring with an air gap or the field circuit of a motor, then the total mmf to produce the flux is the sum of the mmfs to produce the flux in each part.

$$F = F_1 + F_2 + F_3 + \text{etc}$$

Where $F_1 = \Phi L_1 / (\mu_1 A_1) 10^6$ etc

$$\Phi = (4 \pi / 10) N I \times 10^{-6} / \Sigma(L_i / \mu_i A_i)$$

Where Φ is in weber, I in amps, A in m^2 and L in metres

Example

An iron ring, mean diameter 20 cms, with an air gap of 5 mm is wound with 680 turns.

It takes 5 amps to give a flux density of 0.8 tesla. Find μ for the iron.

Length of iron = $\pi \times 20 / 100 = 0.628$ metres

$$NI = \text{ampere turns} = 5 \times 680 = 3400 \text{ ampere turns}$$

The cross section area of iron $A_1 =$ cross section of air gap $A_2 = A$

$$B = \Phi / A = (4 \pi/10) N I \times 10^{-6} / [L_1/\mu_1 + L_2] \text{ tesla}$$

$$0.8 = (4 \pi/10) \times 3400 \times 10^{-6} / [0.628/\mu + 5/1000]$$

$$0.628 / \mu + 0.005 = 1.26 \times 3400 \times 10^{-6} / 0.8 = 5.355 \times 10^{-3}$$

$$1/\mu = 0.355 \times 10^{-3} / 0.628$$

$$\mu = 1770$$

What current is needed to give the same flux in a ring with the same number of turns and same air gap but twice the diameter.

$$B = (4 \pi/10) N I \times 10^{-6} / [L_1/\mu_1 + L_2]$$

$$0.8 = (4 \pi/10) 680 \times I \times 10^{-6} / [2 \times 0.628/ 1770 + 0.005]$$

$$I = 5.33 \text{ amps}$$

Example

Part of the B – H curve for a ring of iron is;

AmpTurns/cm	5.4	1.3	- 0.4	- 1.0	- 1.4	- 1.6
Tesla	1.1	1.0	0.8	0.6	0	- 0.3

The mean diameter of the ring is 15 cms and it is in two parts separated by 0.2mm

The iron is magnetized by a uniformly distributed coil to a maximum flux density of 1.1 tesla. What are the ampere turns?

The ampere turns for the iron = $5.4 \times \pi \times 15 = 254$

The ampere turns for the air gaps are given by

$$1.26 (\text{ampere turns}) \times 10^{-6} / (2 \times 0.2/1000) \text{ tesla} = B = 1.1$$

$$\text{ampere turns} = 349$$

Total ampere turns = $254 + 349 = 603$

Without altering the current, the ring is separated by a further 0.4 mm. Find B

Ampere turns for the air gaps

$$B = 1.26 (\text{ampere turns}) \times 10^{-6} / (2 \times 0.6/1000) \text{ tesla}$$

$$\text{ampere turns} = B \times (2 \times 0.6/1000) \times 10^6 / 1.26 = 955 \text{ B}$$

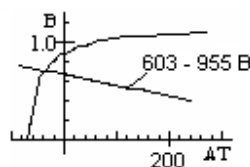

Plot the B-H curve in tesla against ampere turns

And plot (total AT – AT for air gaps)

$$\text{ie AT} = 603 - 955 \text{ B}$$

The plots cross when AT for iron + AT for air gaps = 603

This occurs at a negative AT of 44 and a flux density of 0.621 tesla

The mmf for the air gap is provided partly by the residual magnetism and partly by the ampere turns.

Magnetic Flux from a unit pole

The magnetic field 1 cm from a unit pole is by definition 1 oersted.

But the surface area of the sphere radius 1 cm is $4\pi \text{ cm}^2$

Thus the total magnetic flux leaving a unit pole is 4π maxwells.

In Engineering units, the total flux leaving a unit pole is $4\pi \times 10^{-8}$ weber.

Electrostatics

Electrostatic units (esu)

If an insulating particle becomes charged, it sticks to another insulated body. Particles of polystyrene stick to the window. A nylon shirt pulled over your hair charges up the nylon and it can discharge with visible sparks. This introduces a new set of units. A unit electrostatic charge placed one cm away from a similar unit charge experiences a force of one dyne. The work done in taking an esu unit of charge through an esu unit of voltage is one erg. Many textbooks state that this set of esu units is related to emu units by the velocity of light.

Force on electrostatic charge

A charge q_1 distant d cms from another charge q_2 in dielectric constant k experiences a force

$$F = q_1 q_2 / (k d^2)$$

Electrostatic field

The electrostatic field at any point is the force exerted on a unit charge.

$$f = q / (k d^2)$$

Electrostatic flux

Electrostatic field at the perimeter of a sphere radius d cm in air ($k = 1$) with a charge q at the centre

$$\text{Electrostatic field } f = q / (1 \times d^2) = q / d^2$$

Electrostatic flux = electrostatic field times area

Surface area of sphere radius d cm = $4\pi d^2$

Therefore the total electrostatic flux leaving a charge $q = q \cdot 4\pi$

Gauss's Theorem

Using es units, consider a unit charge q in a vacuum.

The electric induction at $P = q/r^2$

Consider an elemental area δA of the boundary

Electric induction through $\delta A = (q/r^2) \cdot \text{Cos } \theta \delta A$

$$= q \delta \omega$$

where $\delta \omega$ is the solid angle subtended by δA

Adding over the whole surface, total normal electric inductance = $q \cdot 4\pi$

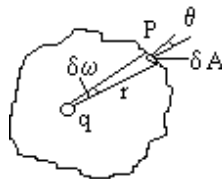

If ϕ is the electric induction at a point P ,

then electric force at P is $F = \phi / k$ where k is the relative permittivity (or dielectric constant)

Induced EMF

Potential Difference (pd)

The potential difference between two points is one volt if one watt of power is produced when one amp flows from one point to the other. The symbol for pd is **V** and the Engineering unit is the **volt**. One joule of work is done when one coulomb of electricity flows through a pd of one volt.

$W = V \cdot I$ where W is in watts, V is in volts and I is in amps

joule is 10^7 ergs and amp is 1/10 em unit

therefore the volt is joules / sec / amp = 10^8 emu

Electro Motive Force (emf)

An emf is generated when the magnetic flux linking with a coil is changed. It is measured in volts. The generated emf is one volt when one amp generates one watt of power.

Faraday's Law

Consider two parallel conductors L metres apart with a third lying across them which carries a current of I amps. Apply a uniform magnetic field B tesla perpendicular to the plane of the conductors

Move the top conductor at a constant velocity v metres/sec against the force on the conductor.



WHILE YOU WERE SLEEPING...

DUKE
THE FUQUA
SCHOOL
OF BUSINESS

www.fuqua.duke.edu/whileyouweresleeping

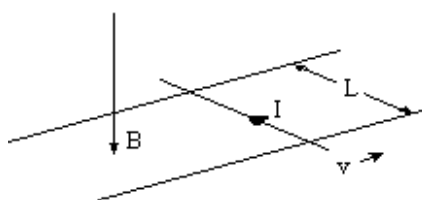

Mechanical power supplied to move the conductor = $B \cdot I \cdot L \cdot v$ watts
 This power is used to generate an emf E in the conductor generating power at the rate $E \cdot I$ watts.

Hence $E = B \cdot L \cdot v$

Where E is in volts, B is in tesla, L in metres and v in metres/sec

But $B \cdot L \cdot v =$ rate at which the top conductor cuts the magnetic flux = $d\Phi / dt$.
 If there are N turns of a coil linking the flux, then

$E = - N \cdot d\Phi / dt$ where E is in volts and $d\Phi/dt$ is in Wb/sec

This is the fundamental equation connecting emf and magnetic flux.

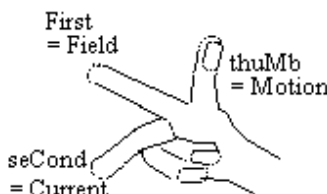

Lenz's law states that the generated emf E opposes the change. Therefore the polarity of E is usually chosen so that it is negative when the flux linked with the circuit is increasing.

Experiment shows that if a conductor is moved in the direction of the right hand thumb in a field in the direction of the right hand first finger then an emf will be generated causing a current to flow in the direction of the second finger.

This is the **right hand rule**, the “gener-right-or” rule.

Resistance (Ohm's law)

At constant temperature, the current in a wire is proportional to the pd between the ends.
 The ratio Volts / Amps is called the resistance in Ohms. The symbol for Ohms is Ω .

$R = V/I$ where R is in ohms, V is in volts and I is in amps

Legal Ohm is the resistance of a column of mercury 106.3 cms long and 1 sq cm cross section at $0^{\circ} C$

Resistance is proportional to the length of the wire and inversely proportional to the cross section.

$R = (\rho L / A)$ where R is in $\mu\Omega$, ρ is the resistivity in $\mu\Omega$ per metre cube, L is the length in metres and A is the cross sectional area of the wire in metres².

Power loss in a resistor

Power loss $W = V \cdot I = I^2 \cdot R = V^2 / R$

Resistance Temperature Coefficient of conductors

Resistance increases with temperature, the increase being approximately linear.

$R = R_0 (1 + \alpha T)$ where R_0 is the resistance at 0° Celsius, T is the temperature in Celsius and α is the temperature coefficient

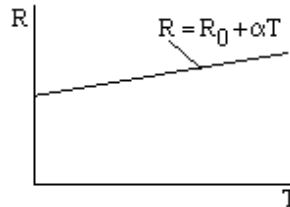

Typical values of ρ and α at 15°C

Copper	$\rho = 1.7 \mu\Omega$ per cm cube	$\alpha = 0.004$
Aluminium	$\rho = 2.9 \mu\Omega$ per cm cube	$\alpha = 0.004$
Silver	$\rho = 1.6 \mu\Omega$ per cm cube	$\alpha = 0.004$
Iron	$\rho = 10\text{-}160 \mu\Omega$ per cm cube	$\alpha = 0.002 - 0.006$

Absolute zero temperature is -273°C . At a temperature near absolute zero, R for some materials becomes zero. The material is said to be supercooled and can carry a huge current with no energy loss. This property is used in some large electro-magnets.

Temperature coefficient of insulation materials

Increase in temperature reduces the insulation resistance and the effect is logarithmic. An increase in temperature of 65°C reduces the insulation resistance by a factor of 10. The insulation resistance is also dependent on how dry it is. Records of insulation resistance should give the temperature at which the measurement was taken.

Work done in taking a unit pole round a closed path through a coil of N turns carrying a current of I amps

The total flux leaving the pole links with the coil.

Thus the total flux linkage is $4\pi N \times 10^{-8}$ weber

Thus the emf generated by moving the pole is;

$$E = 4\pi N \times 10^{-8} / t \text{ where } t \text{ is the time taken.}$$

Power generated = $E I$ watts = $4\pi N I \times 10^{-8} / t$ for t secs

Work done = $4\pi N I \times 10^{-8}$ joules

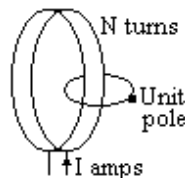

Self Inductance

The current in a coil causes a magnetic field that links with the coil. Therefore any change in the current will induce an emf in the coil. The coil is said to have self inductance. The symbol for self inductance is **L** and the Engineering unit is the **henry**. A coil is said to have an inductance of one henry if a rate of change in current of one amp per second induces an emf of one volt.

$E = -L \cdot dI/dt$ where E is in volts, L is in henries, I is in amps and t is in seconds. The minus sign signifies that the emf opposes the change.

Self Inductance of a coil

A coil is wound with N turns on a ring D metres mean diameter and cross sectional area A square metres and permeability μ .

Let the current be I amps

Magnetising force, $H = 4 \pi N I / (\pi D) \times 10^{-7}$

$\Phi = \mu H A$ Weber

$\Phi = 4 \pi \mu N I A / (\pi D) \times 10^{-7}$ Wb.

emf due to change in I is given by;

$E = -N d\Phi/dt = -N 4 \pi \mu N A / (\pi D) \times 10^{-7} dI/dt$ volts

$= - (4 N^2 \mu A / D) \times 10^{-7} dI/dt$ volts

But $E = -L dI/dt$

Therefore $L = (4 N^2 \mu A / D) \times 10^{-7}$ henries

For a magnetic circuit length S metres

$L = 1.26 N^2 \mu A / S \times 10^{-6}$ henries

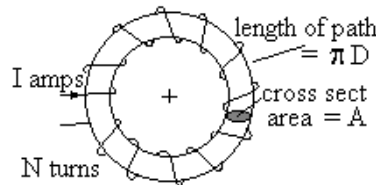

Example

A coil of 500 turns is wound on a wooden ring 20 cms diameter
The cross section of the ring is 4 cms diameter. Estimate the self inductance

$L = (4\pi/10) \times 500^2 \times [\pi \times (2/100)^2] \times 10^{-6} / (\pi \times 0.2) = 2\pi \times 10^{-4}$ henries

Self Inductance of two parallel lines spaced d metres apart

Conductors A and B form a coil of one turn in air
Each carries a current I amps

Flux at P due to conductor A $= (2 I / x) \times 10^{-7} L \delta x$

Total flux linkage $= (2 I L) \times 10^{-7} \int (1/x) dx$ from a to d
 $= [2 I L \ln(d/a)] \times 10^{-7}$

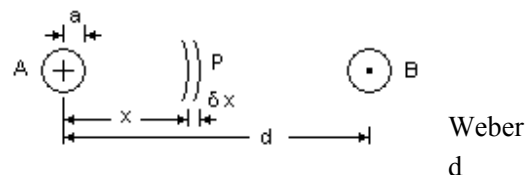

But there is also flux linkage within conductor A

Flux linkage in element within conductor A $= (2 I x / a^2) 10^{-7} L \delta x$ Weber

But this links with only (x^2 / a^2) of the conductor

Total flux linkage within conductor A $= (2 I x^3 / a^4) 10^{-7} L \delta x$ Weber

Total flux linkage within the conductor $= (2 I L / a^4) 10^{-7} \int x^3 dx$ from 0 to a
 $= (2 I L / a^4) 10^{-7} (a^4 / 4) = (I L / 2) 10^{-7}$

Hence the total linkage due to I amps in A $= [2 I L \ln(d/a) + I L / 2] 10^{-7}$

Total linkage due to I amps in conductors A and B $= I L [1 + 4 \ln(d/a)] 10^{-7}$

Self Inductance per metre length $= [1 + 4 \ln(d/a)] 10^{-7}$ **Henries**

Energy stored in an inductance

An inductance L henries carries a current I amps.

Let the inductance be disconnected from the supply but allowed to discharge through a resistor. The power supplied by the inductance;

$$w = e i \text{ watts}$$

where w, e and i are the values of power, emf and current at any instant during the discharge.

$$e = -L di/dt \quad w = -L i di/dt$$

Energy released during the discharge

$$= \int w dt = \int -L i di/dt dt$$

$$= \int -L i di \text{ from } i = I \text{ to } i = 0$$

$$= - (1/2) L i^2 \text{ from } i = I \text{ to } i = 0$$

$$= (1/2) L I^2 \text{ joules}$$

Discharge Resistor

When the current in an inductor is suddenly switched off, di/dt has a very high negative value. In practice this means that attempting to switch the current off results in severe arcing at the switch contacts.

Thus the switch for a large inductor is usually double pole which connects the inductor to a discharge resistor before the connection to the supply is broken.

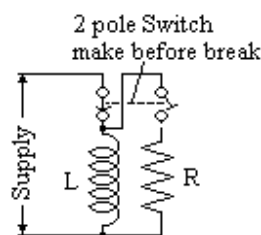

Inductance discharged through a resistance

When an inductance L henries is discharged through a resistance R ohms, the current decays exponentially with a time constant T

Let I_0 be the current at $t = 0$

$$E = -L \frac{di}{dt} \text{ and } E = iR$$

$$(L/i)di = R dt$$

$$\int (1/i) di \text{ from } I_0 \text{ to } i = - (R/L) \int dt \text{ from } 0 \text{ to } t$$

$$\ln(i/I_0) = - (R/L)t$$

$$i = I_0 e^{-(R/L)t}$$

But $i = I_0 e^{-(t/T)}$ for exponential decay with time constant T

Hence the current decays exponentially with a time constant $T = L/R$

Inductance charged through a resistance from constant volt supply

When $t = 0$, the current is zero

$$\text{At time } t, V = L \frac{di}{dt} + iR$$

Multiply by integrating factor $e^{R/L t}$

$$V e^{R/L t} = L e^{R/L t} \frac{di}{dt} + R i e^{R/L t}$$

$$= L \frac{d}{dt} [i e^{R/L t}]$$

Integrating

$$(L/R) V e^{R/L t} = L [i e^{R/L t}] + \text{Const}$$

When $t = 0, i = 0$ therefore Constant = $(L/R)V$

$$i = V/R - V/R e^{-R/L t} = (V/R) (1 - e^{-R/L t})$$

The current rises exponentially with a time constant $T = L/R$ towards $I = V/R$

Excellent Economics and Business programmes at:



university of groningen



“The perfect start of a successful, international career.”

CLICK HERE
to discover why both socially and academically the University of Groningen is one of the best places for a student to be

www.rug.nl/feb/education



Power to inductance charged through a resistance

Power to inductance $W = v i = i L di/dt$

$$W = [(V/R) (1 - e^{-R/L t})] [L (V/R) (R/L) e^{-R/L t}]$$

$$W = (V^2/R) (e^{-R/L t}) (1 - e^{-R/L t})$$

Put $x = (e^{-R/L t})$ $W = (V^2/R) (x - x^2)$

$$dW/dx = (V^2/R) (1 - 2x)$$

$$dW/dx = 0 \text{ when } x = 1/2$$

$$d^2W/dx^2 = (V^2/R) (-2) \text{ which is negative}$$

Therefore W is a maximum when $x = 1/2$

$$W_{MAX} = (V^2/R) [1/2 - (1/2)^2]$$

$$= V^2/(4R) \text{ and is independent of } L$$

Change in Flux and Quantity

A coil with N turns is connected to a circuit with a total resistance R ohms.

The Flux through the coil is Φ

$$- N d\Phi/dt = I R = dq/dt R$$

Integrate wrt t from 1 to 2

$$N (\Phi_1 - \Phi_2) = R (q_2 - q_1) \text{ where } \Phi \text{ is in weber, } q \text{ is in coulombs and } R \text{ is in ohms}$$

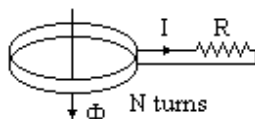

Electrostatic field inside a conducting sphere

Let the density of charge on the surface of a hollow conducting sphere be σ per unit area.

Point P experiences a force due to area ω_1 of

$$F = \sigma \omega_1 \text{ Cos } (\phi_1) / (k r_1^2) - \sigma \omega_2 \text{ Cos } (\phi_2) / (k r_2^2)$$

$\omega_1 \text{ Cos } (\phi_1) / r_1^2$ and $\omega_2 \text{ Cos } (\phi_2) / r_2^2$ are equal solid angles

The charge σ on the surface of the sphere exerts no Force on a charge at P
Hence there is no electrostatic field inside the sphere.

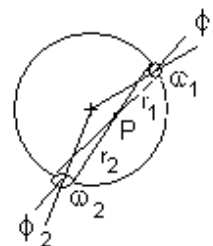

Electrostatic field external to the sphere

Force on a unit charge external to the sphere = $q / k x^2$

where x is the distance of the unit charge from the centre of the sphere

In any set of units, the voltage difference between two points is the work done in taking a unit charge from one point to the other. The electrostatic unit of voltage on the sphere is the work done in ergs when an electrostatic unit of charge is brought from infinity to the surface of the sphere.

$$V = (q / k) \int [x^{-2}] dx \text{ from infinity to the radius of the sphere } a \text{ cm.}$$

$$= q / k a$$

$$q = k a V \text{ where all quantities are in esu}$$

Capacitor

A capacitor stores a quantity of electricity. The storage is proportional to the voltage and capacitance.

The symbol for capacitance is C

The SI unit is the farad = coulombs/volt but this is too large for practical use. The Engineering unit is the microfarad (μF) = 10^{-6} farad.

$$q = C \cdot V \text{ where } C, q \text{ and } V \text{ are in the same units}$$

Conversion of esu units to mks units

1 esu of quantity = $1 / (3 \times 10^{10})$ emu of quantity = $1/(3 \times 10^9)$ coulomb

where 3×10^{10} cm/sec is the speed of light (actually 2.998×10^{10})

1 esu of pd = 3×10^{10} emu of pd = $3 \times 10^{10} \times 10^{-8}$ volts = 3×10^2 volts

thus 1 esu of capacitance = (1 esu of quantity) / (1 esu of pd)

$$= [1/(3 \times 10^9) \text{ coulomb}] / [3 \times 10^2 \text{ volts}]$$

$$= [1/(9 \times 10^{11})] \text{ coulombs / volt}$$

$$= [1.11 \times 10^{-12}] \text{ coulombs / volt or farads}$$

$$= [1.11 \times 10^{-12} \cdot 10^6] \mu\text{F}$$

$$= [1.11 \times 10^{-6}] \mu\text{F}$$

hence (value of C in μF) = $1.11 \times 10^{-6} \times$ (value of C in es units)

The quantity of electricity stored by an isolated sphere $q = k a V$

Therefore the capacitance of the sphere $C = k a$ in electrostatic units

Isolated sphere

$C = k a$ in es units

$C = 1.11 \cdot 10^{-6} \cdot k a$ μF where a is in cm

Voltage gradient = $V a / x^2$ Volts / cm

Where V is the potential of the sphere in Volts, a cm is the radius of the sphere and x cm is the distance from the sphere centre

Concentric spheres

Smaller sphere radius a cm, larger sphere radius b cm

Apply a charge q to sphere radius a and a charge $-q$ to sphere radius b .

Voltage on inner sphere $V = q / (k a)$ due to its own charge

Voltage inside the outer sphere $V = -q / (k b)$

Resultant potential of inner sphere $V = q / (k a) - q / (k b) = (q / k) [(b - a) / (ab)]$

$$C = q / V = k a b / (b - a)$$

$C = 1.11 \cdot 10^{-6} \cdot k a b / (b - a)$ microfarads

Parallel plate condenser

Let area of plate = A sq cm

and charge on the plate = σ per unit area

Total normal electric induction

$$= 4\pi \sigma / k \text{ per unit area}$$

V equals the work done in taking the charge from one plate to the other

$V = \int F dx = 4\pi \sigma d / k$ where d is the distance between the plates in cms

The capacitance of the condenser $C = q / V = A\sigma / V = A k / (4\pi d)$ in es units

$C = 1.11 \times 10^{-6} \times A k / (4\pi d)$ microfarads

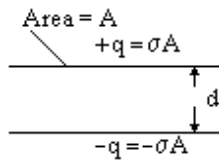

Parallel plate condenser with two insulations

Electric induction $\phi = 4\pi \sigma$

$F_a = \phi / k_a = 4\pi \sigma / k_a$ per unit area

$F_b = \phi / k_b = 4\pi \sigma / k_b$ per unit area

.....Alcatel-Lucent

www.alcatel-lucent.com/careers

One generation's transformation is the next's status quo. In the near future, people may soon think it's strange that devices ever had to be "plugged in." To obtain that status, there needs to be "The Shift".



$$V = 4\pi \sigma a / k_a + 4\pi \sigma b / k_b$$

Capacitance per unit area = $\sigma / V = 1/[4\pi(a / k_a + b / k_b)]$ es units

$$C = 1.11 \times 10^{-6} / [4\pi(a / k_a + b / k_b)] \mu\text{F per square cm}$$

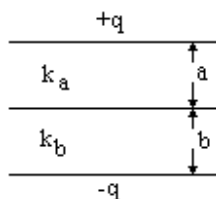

Co-axial cylinders radius a and b, length L

Let charge per unit length = σ

Gauss's theorem $\phi 2\pi r L = 4\pi \sigma L$

$$\phi = 2 \sigma / r$$

$$F = \phi / k = 2 \sigma / (r k)$$

$$V = \int F dr \text{ from } a \text{ to } b$$

$$= (2 \sigma / k) \ln (b / a)$$

Capacitance $C = \sigma / V = k / [2 \ln (b / a)]$ in es units

$$C = 1.11 \times k \times 10^{-6} / [2 \ln (b / a)] \mu\text{F per cm}$$

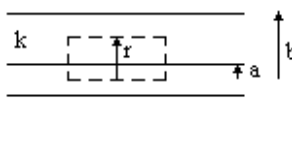

Example 1

Calculate the capacitance per kilometer of a lead covered cable where $a = 2.5$ mm and insulation is 2 mm thick and $k = 4$. Therefore $b = 4.5$ mm.

$$\text{Capacitance / cm} = 1.11 \times 4 \times 10^{-6} / [2 \ln (4.5 / 2.5)] \mu\text{F}$$

$$\text{Capacitance / kilometer} = 1.11 \times 4 \times 10^{-6} / [2 \ln (4.5 / 2.5)] \times 100 \times 1000 = 0.38 \mu\text{F}$$

Example 2

Calculate the capacitance if the outer 1 mm of the insulation has $k = 2$

$\phi = 2 \sigma / r$ throughout the cable.

$$\text{For inner 1 mm, } F_1 = \phi / 4 = 2 \sigma / (4 r)$$

$$\text{For outer 1 mm, } F_2 = \phi / 2 = 2 \sigma / (2 r)$$

$$V = \int F_1 dr \text{ from } .25 \text{ to } .35 + \int F_2 dr \text{ from } .35 \text{ to } .45$$

$$= 2 \sigma [(1/4) \ln(.35/.25) + (1/2)\ln(.45/.35)]$$

$$\text{Hence } \sigma / V = 2.37 \text{ esu / cm} = 2.37 \times 10^5 \text{ esu / km}$$

$$\text{Capacitance} = 1.1 \times 10^{-6} \times 2.37 \times 10^5 \mu\text{F per km} = 0.26 \mu\text{F per km}$$

Parallel conductors

The field at x from a sphere is $f = q / (k x^2)$ since the area covered by each line of flux is proportional to x^2

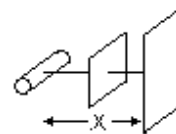

The field at x from a long cylinder is $f = q / (k L x)$ since the area covered by each line of flux is proportional to x not x^2

This is true if the cylinder is isolated and half the electrostatic flux leaves on the opposite side of the conductor. The presence of a second conductor with opposite charge means that all the flux leaves on the same side in effect doubling the field and therefore $f = 2 q / (k L x)$

Conductors A and B are each radius r with distance d between centres

Let charge per unit length on A = σ . Therefore $q = L \sigma$

And charge per unit length on B = $-\sigma$

Electrostatic field at P in due to A = $2 \sigma L / x L k$

Electrostatic field at P in due to B = $2 \sigma L / [L (d - x)]$ in the same direction

Therefore $V = \int 2 \sigma L [1/x + 1/(d - x)] dx$ from r to $d - r$

$$= 2 \sigma L [\ln(x) - \ln(d - x)] \text{ from } r \text{ to } d - r$$

$$= 4 \sigma L [\ln \{ (d - r) / r \}]$$

Capacitance $C = \sigma / V = k / [4 \ln \{ (d - r) / r \}]$ in es units per unit length

$$C = 1.11 \cdot 10^{-6} \cdot k / [4 \ln \{ (d - r) / r \}] \text{ } \mu\text{F per cm}$$

Voltage gradient at distance x cm from one of the conductors

$$= V d / [x (d - x) \ln \{ (d - r) / r \}] \text{ volts/cm}$$

Where V is difference in potential of the conductors in Volts, d cm is the distance between the conductor centres and r cm is the radius of each conductor

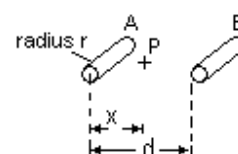

Energy stored in a capacitor

Work done in increasing the charge by $\delta q = V \delta q$

But $q = C V$

$$\delta q = C \delta V$$

Work done = $C V \delta V$

Energy stored $\int C V dV$ from $V = 0$ to $V = V$

Energy stored = $(1/2) C V^2$ where energy is in joules, C is in farads and V is in volts

Capacitor discharged through a resistance

At time t , $q = C v$ and $v = iR$ and $i = dq/dt$

$$q = CR dq/dt$$

Integrate from q_0 to q , $CR \ln(q/q_0) = -t$

$$q = CR i, \text{ therefore } CR \ln(i/i_0) = -t \text{ hence } i = i_0 e^{-(1/CR)t}$$

The current decays exponentially with a time constant $T = CR$

Capacitor charged through a resistance from a supply at constant voltage V

When $t = 0$, $q = 0$

At time t , $q = Cv$ and $V = iR + q/C$ and $i = dq/dt$

$$q/CR + dq/dt = V/R$$

Multiply by the integrating factor $e^{(1/CR)t}$

$$d/dt [q e^{(1/CR)t}] = (V/R) e^{(1/CR)t}$$

Integrating

$$q e^{(1/CR)t} = (V/R) (CR) e^{(1/CR)t} + \text{constant} = (CV) e^{(1/CR)t} + \text{constant}$$

When $t = 0$, $q = 0$ therefore constant = $-CV$

$$q = CV [1 - e^{-(1/CR)t}]$$

The charge rises exponentially with a time constant $T = CR$ towards $Q = CV$

Join the best at the Maastricht University School of Business and Economics!

Top master's programmes

- 33rd place Financial Times worldwide ranking: MSc International Business
- 1st place: MSc International Business
- 1st place: MSc Financial Economics
- 2nd place: MSc Management of Learning
- 2nd place: MSc Economics
- 2nd place: MSc Econometrics and Operations Research
- 2nd place: MSc Global Supply Chain Management and Change

Sources: Keuzegids Master ranking 2013; Elsevier 'Beste Studies' ranking 2012; Financial Times Global Masters in Management ranking 2012

Maastricht University is the best specialist university in the Netherlands (Elsevier)

Visit us and find out why we are the best!
Master's Open Day: 22 February 2014

www.mastersopenday.nl

DC Circuits

Internal resistance of a cell

The current I in a circuit of resistance R connected to a cell of voltage E and internal resistance r is

$$I = E / (R + r)$$

If V is the voltage across R

then $V = IR$

hence $r = (E - V) / I$

E is the voltage on open circuit and can be measured with a potentiometer

hence r can be found.

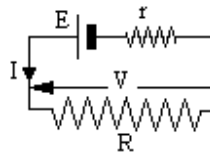

Alternatively;

If I_1 is the current with Resistance R_1 and I_2 is the current with Resistance R_2

Then $I_1 (R_1 + r) = E = I_2 (R_2 + r)$

Thus $r = (I_2 R_2 - I_1 R_1) / (I_1 - I_2)$

Resistances in series

$$V_1 = I R_1$$

$$V_2 = I R_2$$

$$V = I R$$

$$V = V_1 + V_2$$

$$I R = I R_1 + I R_2$$

$$\text{Hence } R = R_1 + R_2$$

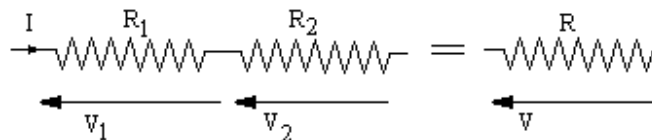

Resistances in parallel

$$V = I_1 R_1$$

$$V = I_2 R_2$$

$$V = I R$$

$$I_1 = V / R_1$$

$$I_2 = V / R_2$$

$$I_1 + I_2 = I = V / R$$

$$V / R = V / R_1 + V / R_2$$

$$R = 1 / [(1 / R_1) + (1 / R_2)]$$

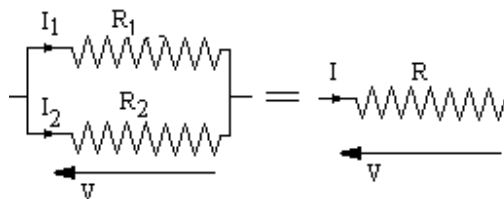

Kirchoff's first law

The total current leaving any portion of a network is equal to the total current entering that portion.

Kirchoff's second law

The algebraic sum of all the "IR" drops around any circuit is equal to the total emf applied in that circuit.

Example 1

In the diagram,

$$E_1 - I_1 r_1 = V = I_2 R$$

$$E_2 - (I_2 - I_1) r_2 = V = I_2 R$$

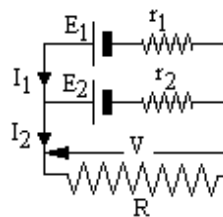

Hence $I_1 = (E_1 - I_2 R) / r_1$

$$E_2 + I_1 r_2 = I_2 (R + r_2)$$

$$E_2 + (E_1 - I_2 R) r_2 / r_1 = I_2 (R + r_2)$$

$$E_1 r_2 + E_2 r_1 = I_2 (R r_1 + R r_2 + r_1 r_2)$$

$$I_2 = (E_1 r_2 + E_2 r_1) / (R r_1 + R r_2 + r_1 r_2)$$

Example 2

Each edge of a tetrahedron is resistance R
Find the resistance between adjacent corners.

By symmetry, four bars carry I_1 , one bar carries zero and the sixth carries $I - 2I_1$

$$V = I_1 R + I_1 R \text{ therefore } I_1 = V / (2R)$$

$$V = (I - 2 I_1) R = IR - V$$

$$2V = IR$$

Resistance between adjacent corners = $V/I = R/2$

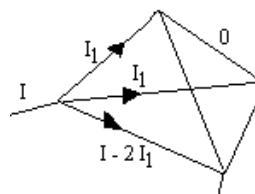

Thevenin's Theorem

To find the current in a resistance r , a branch of a network, remove the branch and find the voltage E across the ends of the branch. Short circuit all sources of emf and find the resistance R of the network between the ends of the branch with the branch removed. The current in the branch is $E / (R + r)$.

Example

Find the current in branch QS
All values are in ohms.

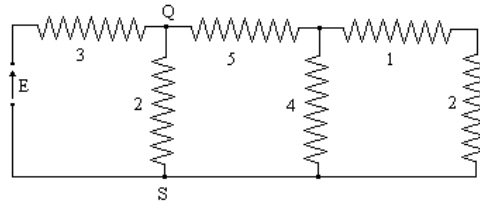

4 ohm resistor in parallel with 1 and 2

equals $1/(1/4 + 1/3) = 12/7$

Remove QS and

voltage between Q and S = $E (5 + 12/7) / (8 + 12/7) = 0.691 E$

Resistance between Q and S = $1/[1/3 + 1/(5 + 12/7)] = 2.074$

Current in QS = $0.691 E / (2.074 + 2) = 0.170 E$

> Apply now

REDEFINE YOUR FUTURE
AXA GLOBAL GRADUATE PROGRAM 2014

redefining / standards 

agence cdg © Photonistop



Wheatstone Bridge

A Wheatstone Bridge consists of four resistances connected as shown. D is a galvanometer to detect any current.

If the galvanometer cannot detect any current, then $P/Q = R/S$.

For example, P, Q and R are resistances that can be switched to any value within a range. An unknown resistance S is connected and P, Q and R adjusted till the galvanometer shows the bridge to be balanced. Hence the value of S can be found.

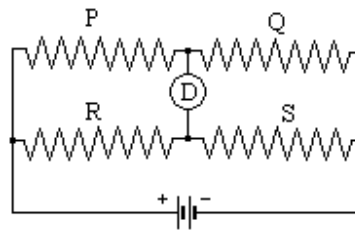
Potentiometer

A voltage V connected internally through a high resistance cannot be measured by a meter. As soon as the meter takes current, the voltage drops.

A potentiometer allows the voltage to be measured without taking any current. A dc supply and voltmeter E are connected across a uniformly wound rheostat

The slider is connected to the unknown voltage through a galvanometer D . The slider is adjusted till the galvanometer shows no current.

$$V = E L_1 / (L_1 + L_2)$$

As no current is flowing from V , there is no volt drop in its resistance.

The output from a thermocouple which measures temperature is usually connected to a potentiometer. The voltage is small (in the order of millivolts) and any resistance drop would introduce a significant error.

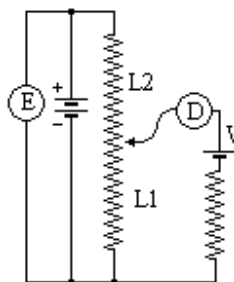

Alternating Current (AC)

Generating an AC voltage

The coil, area A , is rotated in a uniform magnetic field B at constant angular velocity ω

the flux linking the coil is $\Phi = BA \cos \theta$

hence $\Phi_{\max} = BA$ and $\Phi = \Phi_{\max} \cos \theta$

The coil is rotated at constant speed ω , thus $\theta = \omega t$

$$\text{emf } e = -N \frac{d(\Phi_{\max} \cos \omega t)}{dt}$$

$$= N\omega \Phi_{\max} \sin \omega t$$

$$= E_p \sin \omega t$$

where E_p is the maximum value of e

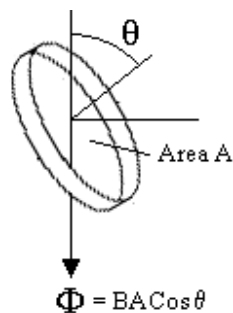

when this emf is applied to a circuit, the current flows in one direction for half a cycle then flows in the reverse direction for the next half cycle. This is called Alternating Current. Throughout the world, mains electricity is normally AC.

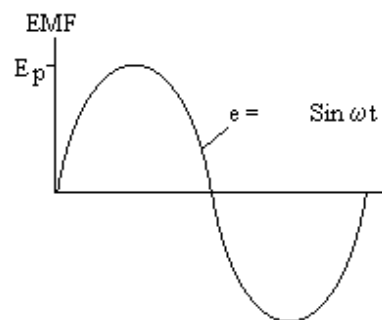

Average value

The average value for a full cycle is zero

Integrate over a half cycle to obtain the average value for half a cycle

$$E_{\text{mean}} \pi = \int_0^{\pi} E_p \sin \theta \, d\theta \quad \text{from } 0 \text{ to } \pi = E_p [-\cos \theta]_{\text{from } 0 \text{ to } \pi}$$

$$E_{\text{mean}} = 2 E_p / \pi = 0.636 E_p$$

Root Mean Square value (rms value)

Integrate the value of e^2 over a full cycle to obtain the average value of e^2

$$\begin{aligned}
 2\pi \text{ (average value of } e^2) &= \int E_p^2 \sin^2 \theta \, d\theta \text{ from } 0 \text{ to } 2\pi \\
 &= \frac{1}{2} E_p^2 \int (1 - \cos 2\theta) \, d\theta \text{ from } 0 \text{ to } 2\pi \\
 &= \frac{1}{2} E_p^2 [\theta - \frac{1}{2} \sin 2\theta] \text{ from } 0 \text{ to } 2\pi \\
 &= \frac{1}{2} E_p^2 (2\pi - 0 - 0 + 0) = \pi E_p^2
 \end{aligned}$$

Hence average value of $e^2 = \frac{1}{2} E_p^2$

Take the square root to obtain the rms value

$$E_{rms} = E_p / \sqrt{2} = 0.707 E_p$$

The power of an electrical circuit is proportional to e^2 hence the use of the E_{rms} value Unless stated otherwise, the value given for an AC voltage or current is the rms value. A DC voltage is equivalent to an AC voltage with the same rms value.

Peak factor and Form factor

Peak factor = (peak value) / (rms value)

Form factor = (rms value) / (av value for $\frac{1}{2}$ cycle)

$$\text{Sine wave form factor} = (0.707) / (0.636 E_p) = 1.11$$

Triangular wave form $E = E_p \theta / (\pi/2)$ between 0 and $\pi/2$

$$\begin{aligned}
 E_{av} &= 0.5 E_p \\
 E_{rms} &= E_p \sqrt{[\int \{\theta^2 / (\pi/2)^2\} \, d\theta / (\pi/2)]} \\
 &\quad \text{with the integral from } 0 \text{ to } \pi/2 \\
 E_{rms} &= E_p / (\pi/2)^{3/2} \sqrt{[\int \theta^2 \, d\theta]} \\
 E_{rms} &= E_p / (\pi/2)^{3/2} \sqrt{[\theta^3 / 3 \, d\theta]} \text{ from } 0 \text{ to } \pi/2 \\
 E_{rms} &= E_p / (\pi/2)^{3/2} \sqrt{[(\pi/2)^3 / 3]} = E_p / \sqrt{3} = 0.577 E_p
 \end{aligned}$$

$$\text{Triangular wave Form factor} = 0.577 E_p / 0.5 E_p = 1.15$$

Square wave $E_{av} = E_p$ and $E_{rms} = E_p$

$$\text{Square wave form factor} = E_p / E_p = 1$$

Summarising

Sine wave form factor = 1.11	peak factor = $\sqrt{2} = 1.41$
Square wave form factor = 1	peak factor = 1
Triangular wave form factor = 1.15	peak factor = $\sqrt{3} = 1.73$

Thus the form factor is a measure of how peaky the wave is.

Example

Find the average value for half cycle, the rms value and the form factor of the wave shown where $3T = \pi$

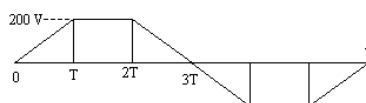

Average value for 1/2 cycle = $2 \times 200/3 = 133$ volts

$$\begin{aligned} \text{rms value} &= \sqrt{\left\{ 2 \times \int 200^2 (t/T)^2 dt + 200^2 \times T \right\} / \pi} \text{ where the integral is from 0 to } T \\ &= \sqrt{200^2 \times \left\{ 2 t^3 / (3T^2) + T \right\} / \pi} \text{ where the integral is from 0 to } T \\ &= \sqrt{200^2 \times \left\{ 2T^3 / (3T^2) + T \right\} / \pi} = 200 \times \sqrt{5T/3} / \pi \text{ where } T = \pi/3 \\ &= \sqrt{200^2 \times \left\{ 5\pi / 9 \right\} / \pi} = \sqrt{200^2 \times 5 / 9} \\ &= 200 \times \sqrt{5 / 3} = 149 \text{ volts} \end{aligned}$$

Form factor = rms value / average value = $149 / 133 = 1.12$

Frequency

The number of complete cycles per second is the frequency in Hertz (Hz)

Mains electricity is at a frequency of 50 Hz in Europe and 60 Hz in America.

$e = E_p \sin \omega t$ so the time taken for N cycles is given by $\omega T = 2 \pi N$

Therefore $T = 2 \pi N / \omega$ But the time taken for N cycles = N / f

Hence $N / f = 2 \pi N / \omega$ thus $\omega = 2 \pi f$

AC voltage $E = E_p \sin (2\pi f t)$

Empowering People. Improving Business.

BI Norwegian Business School is one of Europe's largest business schools welcoming more than 20,000 students. Our programmes provide a stimulating and multi-cultural learning environment with an international outlook ultimately providing students with professional skills to meet the increasing needs of businesses.

BI offers four different two-year, full-time Master of Science (MSc) programmes that are taught entirely in English and have been designed to provide professional skills to meet the increasing need of businesses. The MSc programmes provide a stimulating and multi-cultural learning environment to give you the best platform to launch into your career.

- MSc in Business
- MSc in Financial Economics
- MSc in Strategic Marketing Management
- MSc in Leadership and Organisational Psychology

BI NORWEGIAN BUSINESS SCHOOL

EFMD **EQUIS ACCREDITED**

www.bi.edu/master



Vector representation of AC

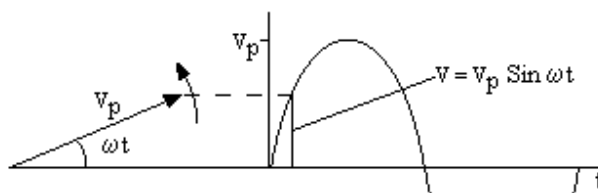

Let the vector V_p rotate anti-clockwise at a speed of ω radians/sec.
 The projection of V_p on a vertical is sinusoidal with respect to time.

Let another vector I_p at an angle of Φ with V_p also rotate anti-clockwise at the same speed of ω radians/sec.

The projection of I_p on the vertical is sinusoidal displaced Φ behind of V_p .

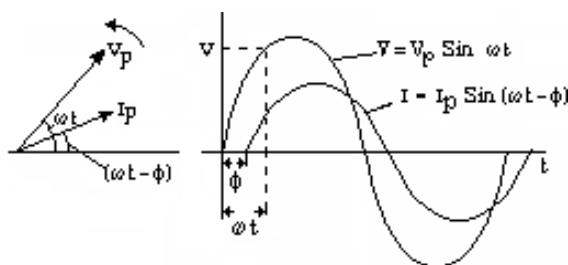

The vectors V_p and I_p represent the two sinusoidal quantities.
 Thus alternating currents and voltages can be represented by vectors.

Addition of two AC voltages or two AC currents

Let V_1 and V_2 be two AC voltages at the same frequency but of different magnitude and phase angle.

$$V_1 = V_{p1} \sin(\omega t + \theta_1) \text{ and } V_2 = V_{p2} \sin(\omega t + \theta_2)$$

$$V_1 + V_2 = V_{p1} [\sin \omega t \cos \theta_1 + \cos \omega t \sin \theta_1] + V_{p2} [\sin \omega t \cos \theta_2 + \cos \omega t \sin \theta_2]$$

$$= \sin \omega t [V_{p1} \cos \theta_1 + V_{p2} \cos \theta_2] + \cos \omega t [V_{p1} \sin \theta_1 + V_{p2} \sin \theta_2]$$

$$\text{Put } V_1 + V_2 = V_{p3} [\sin \omega t \cos \theta_3]$$

$$= \sin \omega t (V_{p3} \cos \theta_3) + \cos \omega t (V_{p3} \sin \theta_3)$$

$$\text{Thus } [V_{p1} \cos \theta_1 + V_{p2} \cos \theta_2] = V_{p3} \cos \theta_3$$

$$\text{And } [V_{p1} \sin \theta_1 + V_{p2} \sin \theta_2] = V_{p3} \sin \theta_3$$

Inspection of the vector diagram of the two voltages shows that this result could have been obtained directly from the vector diagram.

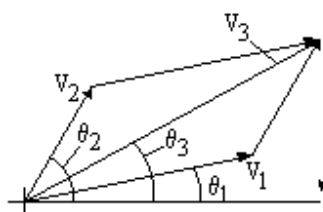

$$\tan \theta_3 = V_{p3} \sin \theta_3 / (V_{p3} \cos \theta_3)$$

$$= [V_{p1} \sin \theta_1 + V_{p2} \sin \theta_2] / [V_{p1} \cos \theta_1 + V_{p2} \cos \theta_2]$$

$$\text{and } V_{p3} = \sqrt{[(V_{p3} \sin \theta_3)^2 + (V_{p3} \cos \theta_3)^2]}$$

$$= \sqrt{[(V_{p1} \sin \theta_1 + V_{p2} \sin \theta_2)^2 + (V_{p1} \cos \theta_1 + V_{p2} \cos \theta_2)^2]}$$

If two AC voltages V1 and V2 (at the same frequency but different phase) are added together, the result is another AC voltage whose magnitude is the vector addition V1 + V2.

Similarly if two AC currents I1 and I2 (at the same frequency but different phase) are added together, the result is another AC current whose magnitude is the vector addition I1 + I2.

The vectors have been shown as the peak value of the vector. However the rms value of a sine wave is always $1/\sqrt{2}$ times the peak value. Thus the vector diagram of the rms values is exactly the same to a different scale as the vector diagram for the peak values.

The vector diagrams of voltage and current are therefore the rms values unless otherwise stated.

Power in a single phase AC circuit

The power in an AC circuit is the product of Volts and Amps.

Let the phase angle between voltage and current be ϕ .

$$\text{Let } v = V_p \sin x \text{ and } i = I_p \sin (x + \phi)$$

$$w = V_p I_p \sin x \sin (x + \phi)$$

$$= V_p I_p \sin x (\sin x \cos \phi + \cos x \sin \phi)$$

$$= V_p I_p [\sin^2 x \cos \phi + (1/2) \sin 2x \sin \phi]$$

The mean value of $\sin 2x$ over a complete cycle is zero,

$$w = V_p I_p \cos \phi \sin^2 x$$

$$\text{The mean value of } \sin^2 x = (1/2\pi) \int \sin^2 x \, dx \text{ from } 0 \text{ to } 2\pi$$

$$= (1/2\pi) \int [1 - \cos 2x]/2 \, dx \text{ from } 0 \text{ to } 2\pi$$

$$= (1/4\pi) [x - \sin 2x] \text{ from } 0 \text{ to } 2\pi$$

$$= (1/4\pi) [2\pi - 0 - 0 + 0] = 1/2$$

$$\text{But } V_p I_p = 2V_{\text{rms}} I_{\text{rms}}$$

$$\text{Hence } W = V_{\text{rms}} I_{\text{rms}} \cos \phi$$

Using the rms values $W = V I \cos \phi$

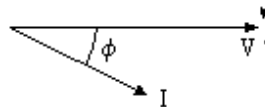

This can be written by the vector equation $W = \mathbf{V} \bullet \mathbf{I}$

$\cos \phi$ is called the power factor (or pf).

Three phase system

If the generator has three coils at 120° spacing, three voltages will be produced with a phase angle of 120° between them.

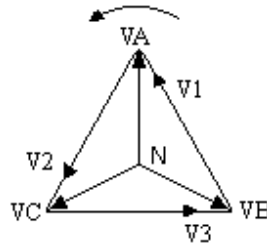

If each voltage is connected to a circuit with the same power factor and the three currents return along the same conductor, then the vector sum of the three return currents is zero. Thus instead of three full sized return cables, only one of smaller size is needed. If none of the load is single phase, then the neutral is not needed at all. High voltage supplies are nearly always three phase without a neutral conductor. There is a great economy in distribution costs if the electricity can be supplied in three phases.

The vector diagram shows the common return point, called the Neutral point, at N and a three phase supply with voltages V_A , V_B and V_C .

These are called the phase voltages or V_{ph} .

Need help with your dissertation?

Get in-depth feedback & advice from experts in your topic area. Find out what you can do to improve the quality of your dissertation!

Get Help Now



Go to www.helpmyassignment.co.uk for more info

 **Helpmyassignment**

The voltages V_1 , V_2 and V_3 are called the line voltages or V_{line} .

It can be seen by the 30° and 60° triangles that the magnitude of the line voltage is $\sqrt{3}$ times the magnitude of the phase voltage.

The voltage of a three phase supply is defined by the line voltage.

Thus a 415 volt three phase supply can provide three separate 240 volt single phase domestic supplies .

If all three phases have currents of the same magnitude and power factor, then the total power

$$W = 3 V_{ph} I \cos \phi = \sqrt{3} V_{line} I \cos \phi$$

$$W = \sqrt{3} V_{line} I \cos \phi$$

Power to a balanced three phase system is constant

$$E_a I_a = E \sin(\omega t) \times I \sin(\omega t - \phi)$$

$$E_b I_b = E \sin(\omega t + 120^\circ) \times I \sin(\omega t + 120^\circ - \phi)$$

$$E_c I_c = E \sin(\omega t - 120^\circ) \times I \sin(\omega t - 120^\circ - \phi)$$

$$\sin A \sin B = \frac{1}{2}[\cos(A - B) - \cos(A + B)]$$

$$E_a I_a = \frac{1}{2}E I [\cos(\phi) - \cos(2\omega t - \phi)]$$

$$E_b I_b = \frac{1}{2}E I [\cos(\phi) - \cos(2\omega t + 240^\circ - \phi)]$$

$$E_c I_c = \frac{1}{2}E I [\cos(\phi) - \cos(2\omega t - 240^\circ - \phi)]$$

$$W = E_a I_a + E_b I_b + E_c I_c$$

$$= \frac{1}{2}E I [3 \cos(\phi) - \cos(2\omega t - \phi) - [\cos(2\omega t + 240^\circ - \phi) + \cos(2\omega t - 240^\circ - \phi)]]$$

$$\cos A + \cos B = 2 \cos\{(A + B)/2\} \cos\{(A - B)/2\}$$

$$W = \frac{1}{2}E I [3 \cos(\phi) - \cos(2\omega t - \phi) - 2\{\cos(2\omega t - \phi) \cos(480^\circ)\}]$$

$$\cos(480^\circ) = -1/2$$

Hence $W = \frac{1}{2} EI 3 \cos(\phi)$ where E and I are peak values per phase

$$E = \sqrt{2} E_{rms} \text{ and } I = \sqrt{2} I_{rms}$$

$$W = 3 E_{rms} I_{rms} \cos(\phi) \text{ where } E_{rms} \text{ is the phase voltage}$$

$$W = \sqrt{3} E_{rms} I_{rms} \cos(\phi) \text{ where } E_{rms} \text{ is the line voltage}$$

This does not include t , ie it is constant for all values of t .

Measurement of power

The power in a three phase, three wire, system can be measured by two single phase wattmeters.

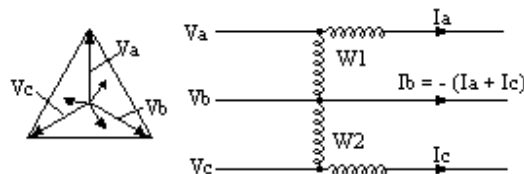

$W1$ reads the vector dot product $(V_a - V_b) \bullet I_a$

$$W1 = (V_a - V_b) \bullet I_a$$

$$W2 = (V_c - V_b) \bullet I_c$$

$$W1 + W2 = V_a \bullet I_a - V_b \bullet (I_a + I_c) + V_c \bullet I_c$$

For a three wire system, $I_a + I_b + I_c = 0$

$$W1 + W2 = V_a \bullet I_a + V_b \bullet I_b + V_c \bullet I_c = \text{total power in the three phases}$$

The sum of two wattmeter readings gives the power in a three phase three wire system. The phases do not need to carry the same current or have the same power factor.

If the load is an electric motor, the voltages are usually balanced

Power Factor measurement by two wattmeters.

Three phase system with the currents and power factors the same on each phase. In this case, the power factor can be obtained from the two wattmeter readings.

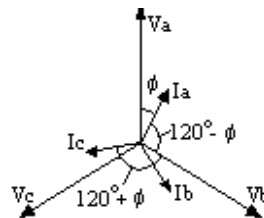

$$W1 = V_a I_a \cos \phi - V_b I_a \cos(120^\circ - \phi)$$

$$W2 = V_c I_c \cos \phi - V_b I_c \cos(120^\circ + \phi)$$

$$V_c I_c \cos \phi = (W1 + W2)/3$$

$$V_b I_c \cos(120^\circ + \phi)$$

$$= V I [\cos 120^\circ \cos \phi - \sin 120^\circ \sin \phi]$$

$$= V I \cos \phi [(-1/2) - (\sqrt{3}/2) \tan \phi]$$

$$= [(W1 + W2)/3] [(-1/2) - (\sqrt{3}/2) \tan \phi]$$

hence

$$W2 = [(W1 + W2)/3] [(3/2) + (\sqrt{3}/2) \tan \phi]$$

$$2 W2 = (W1 + W2) + (1/\sqrt{3}) (W1 + W2) \tan \phi$$

$$W2 - W1 = (1/\sqrt{3}) (W1 + W2) \tan \phi$$

$$\tan \phi = \sqrt{3} (W2 - W1) / (W1 + W2)$$

$$\text{Power factor} = \cos \phi = 1 / \sqrt{1 + \tan^2 \phi}$$

Machine Rating

Generators, Motors and Transformers are rated in kVA or MVA.

Suppose two machines are identical except that one machine operates on twice the voltage of the other. The higher voltage machine has twice the number of turns on the winding. The machines are the same size so the volume of the windings is the same on both machines. The higher voltage machine therefore has each coil approximately twice the length and half the cross sectional area of the other machine. The resistance of the higher voltage winding is therefore about four times the resistance of the lower voltage machine. For the same I^2R heat loss, the higher voltage machine has half the current.

Therefore the higher voltage machine is rated for twice the voltage and half the current. Thus both machines are the same kVA rating. Thus the kVA or MVA rating is a guide to the physical size of the machine and does not depend on the actual voltage or current rating.

For a three phase machine $kVA = \sqrt{3} \times (\text{rated kV}) \times (\text{rated amps})$

Rated power in kW = (rated kVA) x (Cos ϕ) where Cos ϕ is the design power factor

Harmonics

Power from an AC generators often contains harmonics, eg due to fluctuations caused by the slots in the generator rotor and stator. Any harmonics are usually odd harmonics since a wave that is symmetrical about $\pi/2$ can contain odd harmonics but not even harmonics.

The third harmonic is in phase in all three phases thus third harmonic returns through the neutral do not cancel, they add together. Problems in a neutral are often due to third harmonics.

If however a supply containing the third harmonic is connected to the delta winding of a transformer, the third harmonic voltages are in phase at each end of each delta winding. No third harmonic currents flow in the primary delta winding and none appear in the secondary.

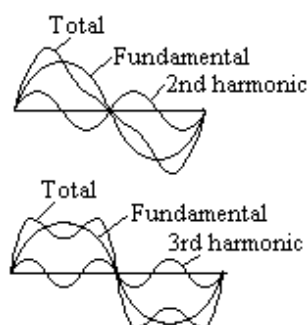

Resistance, Inductance and Capacitance on AC

AC Current through a Resistance

When an AC voltage is applied to a pure resistance,
at any instant, $v = iR$

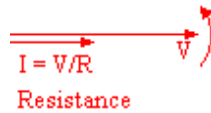

$$I = V/R$$

Resistance

$$V_{\text{rms}} = I_{\text{rms}}R$$

where V_{rms} is in volts, I_{rms} is in amps and R is in ohms
 I is in phase with V

However the Resistance is higher on AC than on DC. This is due to eddy currents causing a power loss.
 $I^2R = \text{copper loss} + \text{eddy current loss}$.



Brain power

By 2020, wind could provide one-tenth of our planet's electricity needs. Already today, SKF's innovative know-how is crucial to running a large proportion of the world's wind turbines.

Up to 25% of the generating costs relate to maintenance. These can be reduced dramatically thanks to our systems for on-line condition monitoring and automatic lubrication. We help make it more economical to create cleaner, cheaper energy out of thin air.

By sharing our experience, expertise, and creativity, industries can boost performance beyond expectations. Therefore we need the best employees who can meet this challenge!

The Power of Knowledge Engineering

Plug into The Power of Knowledge Engineering.
Visit us at www.skf.com/knowledge

SKF



Eddy Currents in a conductor

A conductor, radius a metres carries a current $I \sin(\omega t)$ amps

H outside the conductor is $(2I/r) \sin(\omega t) 10^{-7}$

where r is the distance in metres from the centre of the conductor

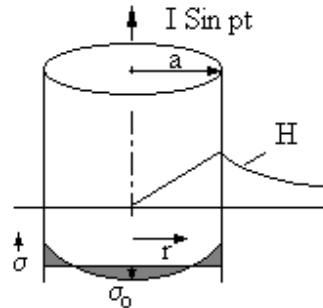

At the surface of the conductor

$$H = (2I/a) \sin(\omega t) 10^{-7}$$

At the centre of the conductor, $H = 0$

Thus inside the conductor

$$H = (2I r/a^2) \sin(\omega t) 10^{-7}$$

Let σ be the eddy current in amps/m^2 at radius r metres

and σ_0 be the current in amps/m^2 at the centre of the conductor

$$\begin{aligned} (\sigma + \sigma_0) \rho &= -\partial\Phi / \partial t \\ &= -\int [\partial H / \partial t] dr \text{ from } r = 0 \text{ to } r = r \\ &= -\int [(2 \rho I / a^2) \cos(\omega t)] 10^{-7} r dr \text{ from } r = 0 \text{ to } r = r \\ &= (\rho I r^2 / a^2) \cos(\omega t) 10^{-7} \end{aligned}$$

hence $\sigma = \rho I r^2 / (a^2) \cos(\omega t) 10^{-7} - \sigma_0$

But $2\pi \int \sigma r dr = 0$ from $r = 0$ to $r = a$
 $2\pi \int [\rho I r^2 / (a^2) \cos(\omega t) 10^{-7} - \sigma_0] r dr = 0$ from $r = 0$ to $r = a$
 $2\pi [\rho I r^4 / (4 \rho a^2) \cos(\omega t) 10^{-7} - \sigma_0 r^2/2] = 0$ from $r = 0$ to $r = a$
 $\rho I a^2 / (4 \rho) \cos(\omega t) 10^{-7} - \sigma_0 a^2/2 = 0$
 $\sigma_0 = \rho I / (2 \rho) \cos(\omega t) 10^{-7}$

hence $\sigma = (\rho I / \rho) \cos(\omega t) [r^2 / a^2 - 1/2] 10^{-7}$ and $\sigma = 0$ when $r = a/\sqrt{2}$

Total current density $i = \sigma + [I \sin(\omega t)] / (\pi a^2)$

Put $[I \sin(\omega t)] / (\pi a^2) = C$
 $i^2 = \sigma^2 + 2\sigma C + C^2$

Energy loss $= 2\pi \int i^2 \rho r dr$ from $r = 0$ to $r = a$
 $= 2\pi \int [\sigma^2 + 2\sigma C + C^2] \rho r dr$ from $r = 0$ to $r = a$

But as before, $2\pi \int \sigma r dr = 0$ from $r = 0$ to $r = a$

Therefore $2\pi \int 2 \sigma C \rho r dr = 0$ from $r = 0$ to $r = a$

Energy loss $= 2\pi \int [\sigma^2 + C^2] \rho r dr$ from $r = 0$ to $r = a$

Additional loss due to eddy currents = integral from 0 to a

$$\begin{aligned} 2\pi \int \sigma^2 \rho r \, dr &= 2\pi (p^2 I^2 / \rho) \text{Cos}^2(pt) 10^{-14} \int [r^5/a^4 - r^3/a^2 + r/4] \, dr \\ &= 2\pi (p^2 I^2 / \rho) \text{Cos}^2(pt) [a^2/6 - a^2/4 + a^2/8] 10^{-14} \\ &= \pi p^2 I^2 a^2 / (12 \rho) \text{Cos}^2(pt) 10^{-14} \end{aligned}$$

Mean value of $I_{\text{max}}^2 \text{Cos}^2(pt) = I_{\text{rms}}^2$

Mean value of energy loss = $\pi p^2 I_{\text{rms}}^2 a^2 / (12 \rho) 10^{-14}$

$$\begin{aligned} \text{Total loss} &= I_{\text{rms}}^2 [\rho / (\pi a^2) + \pi p^2 a^2 / (12 \rho) 10^{-14}] \\ &= I_{\text{rms}}^2 R_0 [1 + \pi^2 p^2 a^4 / (12 \rho^2) 10^{-14}] \end{aligned}$$

where a is in metres and ρ is in ohms per metre cube

hence $R_f / R_0 = 1 + \pi^2 p^2 a^4 / (12 \rho^2) 10^{-14}$

but $p = 2\pi f$

$$R_f / R_0 = 1 + 100\pi^4 f^2 a^4 / (3 \rho^2)$$

where f is in Hz, a is in metres and ρ is in $\mu\Omega$ per cm cube

Example

Conductor 1.29 cm radius, 50 Hz, $\rho = 1.65 \mu\Omega$ per cm cube

$$\begin{aligned} R_f / R_0 &= 1 + 100 \times 3.14^4 \times 50^2 \times (1.29/100)^4 / (3 \times 1.65^2) \\ &= 1.08 \end{aligned}$$

AC Current through an Inductor

Let the inductance be L henries

$$L \, di/dt = \text{back emf}$$

$$= \text{applied voltage } v$$

$$= V_p \text{Sin } 2\pi f t$$

Integrating,

$$L \, i = V_p (1 / 2\pi f) \text{Cos } 2\pi f t + \text{Const}$$

The constant is a DC current (usually zero)

$$i = - [V_p / (2\pi f L)] \text{Cos } 2\pi f t$$

$$I_{\text{rms}} = V_{\text{rms}} / (2\pi f L)$$

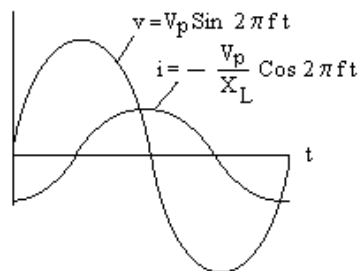

$$\text{But } V_{\text{rms}} = I_{\text{rms}} X_L$$

where X_L is the reactance of the inductor

$$\text{Thus } X_L = 2\pi f L$$

$$\text{At 50 Hz } X_L = 314 L$$

where X_L is in ohms and L is in henries

The current lags the voltage by 1/4 cycle

$$I = V/X$$

$$X = 2\pi f L$$

Inductance

Iron cored inductor

The iron core of an inductor can saturate as the sine wave approaches peak value. If an AC voltage is applied, the current will increase as the peak value is approached. The current wave has a peaky form factor.

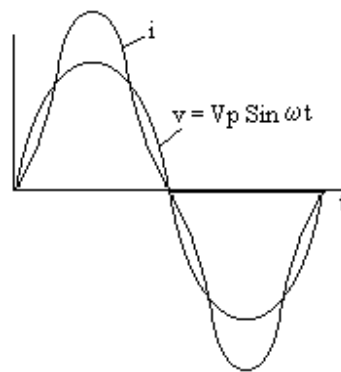

“I studied English for 16 years but...
...I finally learned to speak it in just six lessons”

Jane, Chinese architect

ENGLISH OUT THERE

Click to hear me talking before and after my unique course download



There is another effect. If the rms current through an iron cored reactor is increased, the reactance falls sharply as the iron saturates. If the current is increased in stages from zero and the voltage drop across the reactor is measured, the graph will have a kink as shown. This means that applying a fixed voltage V_c to the reactor, the current can take any one of three values. One of these values, I_2 in the diagram, is unstable but the other two are stable. So applying a voltage within the range can lead to either value of current and any transient can make the current flip to the other value.

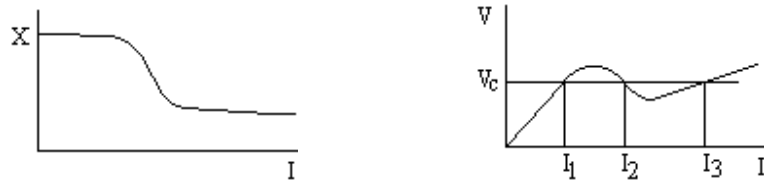

AC Current through a Capacitance (or Condenser)

Let the capacitance be C farads

Thus the charge $q = C v$

where $dq/dt = i$ amps

Put $v = V_p \sin 2\pi f t$

Hence $q = C V_p \sin 2\pi f t$

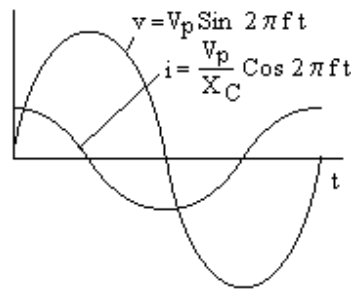

Differentiating wrt t

$$i = C V_p 2\pi f \cos 2\pi f t$$

Hence $I_p = 2\pi f C V_p$

$$I_{rms} = I_p / \sqrt{2} \text{ and } V_{rms} = V_p / \sqrt{2}$$

Hence $I_{rms} = 2\pi f C V_{rms}$

But $V_{rms} = I_{rms} X_C$

where X_C is the reactance of the capacitor in ohms (ie volts/amps)

Thus $X_C = 1 / (2 \pi f C)$

With C in μF then $X_C = 10^6 / (2 \pi f C)$

At 50 Hz $X_C = 3183 / C$

where X_C is in ohms and C is in μF

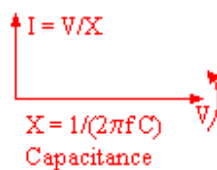

The current is established over several cycles,
but it then lags by $3/4$ cycle.

Thus, in effect, Capacitive Current leads the voltage by $1/4$ cycle

Examples

Find the current taken from the 240 volt 50 Hz mains by;

- (i) 0.12 henry inductance
- (ii) 40 μ F capacitance.

(i) $X = 314 \times 0.12 = 37.7$ ohms $I = V/X = 6.37$ amps

(ii) $X = 3183/40 = 79.6$ ohms $I = V/X = 3.02$ amps

AC Circuits

Series and Parallel Circuits

Resistance, Inductance and Capacitance in series

Let a circuit consist of a Resistor, Inductor and a Capacitor in series all carrying an AC current I

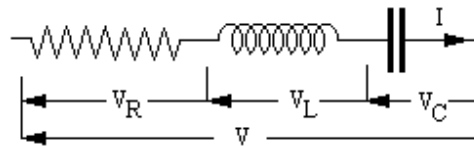

V_R is in phase with I, V_C lags I by 90° and V_L leads I by 90°

$$V_R = IR \text{ and } V_L = j IX_L \text{ and } V_C = -j IX_C$$

where X_L and X_C are the reactances of L and C

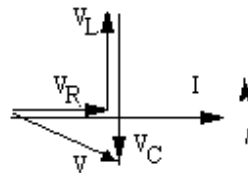

These voltages can be represented by vectors on the same diagram as I

It can be seen from the vector diagram that

$$V^2 = V_R^2 + (V_C - V_L)^2$$

And the current leads the voltage by

$$\text{arc tan } [(V_C - V_L) / V_R] = \text{arc tan } [(X_C - X_L) / R]$$

Where a circuit contains reactance and resistance, the combination is called impedance. The symbol for impedance is Z and the units are ohms.

$$V = I Z$$

$$IZ = IR + j IX_L - j IX_C$$

Thus $Z I = [R + j X_L - j X_C] I$

ie Z can be considered an operator $Z = [R + j X_L - j X_C]$

Magnitude of $Z = \sqrt{[R^2 + (X_L - X_C)^2]}$ by pythagoras, see the vector diagram.

Resonance of a Series LC circuit with a variable frequency AC supply

Let the coil have resistance R ohms and Inductance L henries and the Capacitance be C farads.

The impedance of the circuit

$$Z = R + j 2\pi f L - j / (2\pi f C)$$

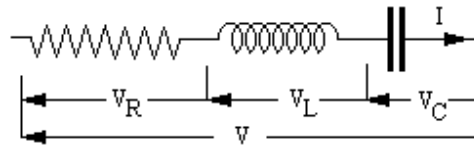

Z has a minimum when $j 2\pi f L = j / (2\pi f C)$ and this minimum value of Z is R
 This occurs at the Resonant Frequency

$$f_0 = 1 / [2\pi \sqrt{(LC) }]$$

The reactance of the coil at resonance = $2\pi f_0 L = \sqrt{(L / C)}$

If a variable frequency supply at a constant voltage is applied to the circuit, a plot of current against f will be of the form shown.

The exact shape depends on the relative values of R and L, ie on the Q factor of the coil where

$$Q \text{ factor} = \text{reactance at resonance} / R = [\sqrt{(L/C) }] / R$$

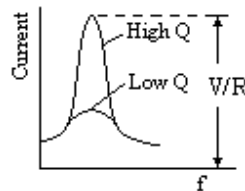

At a frequency $(f_0 + \delta f)$ near resonance,

$$\begin{aligned} Z &= R + j 2\pi(f_0 + \delta f) L - j / [2\pi(f_0 + \delta f) C] \\ &= R + j 2\pi f_0 L + j 2\pi \delta f L - j / [2\pi f_0 C (1 + \delta f / f_0)] \\ &= R + j 2\pi f_0 L + j 2\pi \delta f L - [j / (2\pi f_0 C)] (1 - \delta f / f_0) \\ &= R + j 2\pi \delta f L + [j / (2\pi f_0 C)] (\delta f / f_0) \\ &= R + j 2\pi \delta f L + [j 2\pi f_0 L] (\delta f / f_0) \\ &= R + j 4\pi \delta f L \end{aligned}$$

Hence near resonance, $I = V / (R + j 4\pi L \delta f)$

Phase angle changes rapidly from positive to negative as resonance is passed.

Resistances, Inductances and Capacitances in series on an AC supply

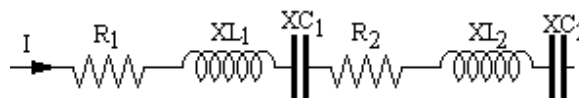

Let the circuit be equivalent to a single resistance R and a single reactance X

By inspection of the vector diagram of voltages, it can be seen that

$$R = R_1 + R_2$$

and $X = XL_1 - XC_1 + XL_2 - XC_2$

If X is positive then X is an inductance

If X is negative then X is a capacitance.

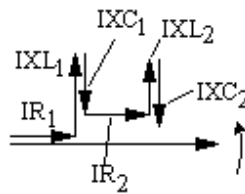

Thus in a circuit containing resistances and reactances in series,
 The equivalent circuit is a **resistance = sum of all the resistances**
 and **reactance = sum of all the reactances**, where inductive reactances are positive and capacitive reactances negative.

Inductive impedances in parallel

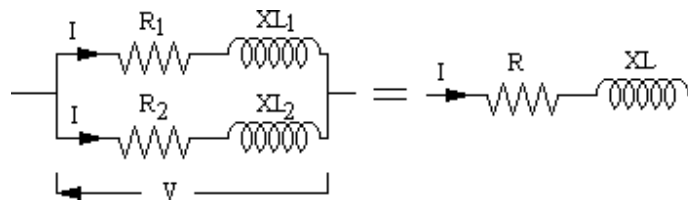

Impedances

$$Z_1 = \sqrt{(R_1^2 + X_1^2)} \text{ and } Z_2 = \sqrt{(R_2^2 + X_2^2)} \text{ and } Z = \sqrt{(R^2 + X^2)}$$

$I =$ vector sum of I_1 and I_2

Hence $I \cos \theta = I_1 \cos \theta_1 + I_2 \cos \theta_2$ and $I \sin \theta = I_1 \sin \theta_1 + I_2 \sin \theta_2$

$I_1 = V / Z_1$ and $I_2 = V / Z_2$ and $I = V / Z$

$$\cos \theta = R / Z$$

$$\cos \theta_1 = R_1 / Z_1$$

$$\cos \theta_2 = R_2 / Z_2$$

$$\sin \theta = X / Z$$

$$\sin \theta_1 = X_1 / Z_1$$

$$\sin \theta_2 = X_2 / Z_2$$

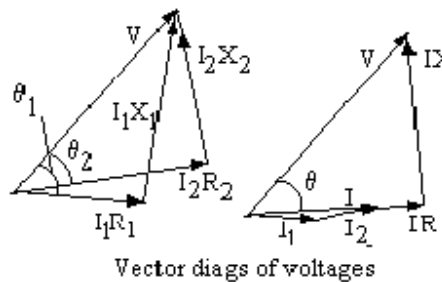

$$(V/Z)(R/Z) = (V/Z_1) (R_1/Z_1) + (V/Z_2) (R_2/Z_2)$$

$$R/Z^2 = R_1/Z_1^2 + R_2/Z_2^2$$

Similarly

$$X/Z^2 = X_1/Z_1^2 + X_2/Z_2^2$$

$$\text{Put } A = R_1 / Z_1^2 + R_2 / Z_2^2 \text{ and } B = X_1 / Z_1^2 + X_2 / Z_2^2$$

$$R/Z^2 = A \text{ and } X/Z^2 = B$$

$$1 / Z^2 = R^2/Z^4 + X^2/Z^4 = A^2 + B^2$$

$$R = A / (A^2 + B^2)$$

$$X = B / (A^2 + B^2)$$

$$\text{Where } A = R_1 / Z_1^2 + R_2 / Z_2^2 \text{ and } B = X_1 / Z_1^2 + X_2 / Z_2^2$$

Inductance and Capacitor or two Capacitors in parallel

If X_1 or X_2 (or both) is a capacitance, then the vector diagrams are still valid except that X has the negative value. The evaluation of R and X are still valid.



What do you want to do?

No matter what you want out of your future career, an employer with a broad range of operations in a load of countries will always be the ticket. Working within the Volvo Group means more than 100,000 friends and colleagues in more than 185 countries all over the world. We offer graduates great career opportunities – check out the Career section at our web site www.volvogroup.com. We look forward to getting to know you!

VOLVO
AB Volvo (publ)
www.volvogroup.com

VOLVO TRUCKS | RENAULT TRUCKS | MACK TRUCKS | VOLVO BUSES | VOLVO CONSTRUCTION EQUIPMENT | VOLVO PENTA | VOLVO AERO | VOLVO IT
VOLVO FINANCIAL SERVICES | VOLVO 3P | VOLVO POWERTRAIN | VOLVO PARTS | VOLVO TECHNOLOGY | VOLVO LOGISTICS | BUSINESS AREA ASIA



Resonance of a parallel LC circuit

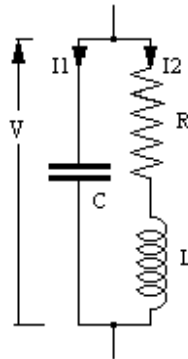

$$I_1 = V / [-j / (\omega C)]$$

$$I_2 = V / [R + j \omega L]$$

$$I_1 + I_2 = V [1 / \{-j / (\omega C)\} + 1 / (R + j \omega L)]$$

$$= V [R + j \omega L - j / (\omega C)] / [(R + j \omega L) \{-j / (\omega C)\}]$$

But $I_1 + I_2 = V / Z$

$$Z = [(R + j \omega L) \{-j / (\omega C)\}] / [R + j \omega L - j / (\omega C)]$$

At resonance, $\omega = \omega_0$ and $j \omega_0 L = j / (\omega_0 C)$

$$Z = [(R + j \omega_0 L) (-j \omega_0 L)] / R$$

$$Q = \omega_0 L / R$$

If Q is large, $R + j \omega_0 L \approx j \omega_0 L$

$$Z \approx j \omega_0 L (-j \omega_0 L) / R = (\omega_0 L)^2 / R$$

$$Z \approx Q^2 R$$

Z is a maximum at resonance

Delta / Star transformation of balanced load

Delta connection

$$I_a = (V_a - V_b) / (R + jX)$$

$$+ (V_a - V_c) / (R + jX)$$

$$= [2V_a - (V_b + V_c)] / (R + jX)$$

But $V_a + V_b + V_c = 0$

$$I_a = 3V_a / (R + jX)$$

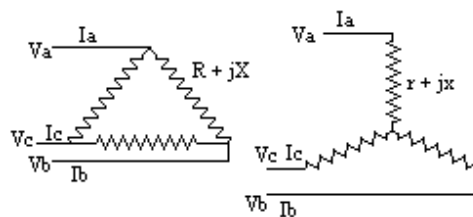

Star connection

$$I_a = V_a / (r + jx)$$

$$\text{Hence } 3 / (R + jX) = 1 / (r + jx)$$

$$R + jX = 3r + 3jx$$

Equate real and imaginary terms $R = 3r$ and $X = 3x$

Example on mains supply power loss

A single phase power line has resistance R ohms per mile in each of the phase and neutral lines.

It supplies a current I_1 to a consumer at the end of the line and a total of I_2 amps to consumers uniformly distributed along its total length of L miles.

Calculate the total power loss in the line.

Current in element δx of the line = $I_1 + I_2 x/L$

Power loss in each element of line and neutral

$$\delta W = (I_1 + I_2 x/L)^2 R \delta x$$

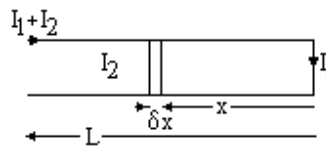

Total power loss in both line and neutral

$$\begin{aligned} W &= 2 \int (I_1 + I_2 x/L)^2 R \, dx \text{ from } 0 \text{ to } L \\ &= 2 R \int [I_1^2 + 2 I_1 I_2 x/L + (I_2 x/L)^2] \, dx \text{ from } 0 \text{ to } L \\ &= 2R [I_1^2 x + 2 I_1 I_2 x^2 / 2L + I_2^2 x^3 / 3L^2] \text{ from } 0 \text{ to } L \\ &= 2 R L [I_1^2 + I_1 I_2 + I_2^2 / 3] \end{aligned}$$

Example on mains supply volt drop

A supply cable has resistance X ohms/km and reactance X ohms/km

It supplies a load I_1 at pf_1 distant L_1 km from the source

and a load I_2 at pf_2 a further L_2 km from the source

and a load I_3 at pf_3 a further L_3 km from the source

Find the voltage required at the source of the supply to give the specified voltage V_3 at the last consumer

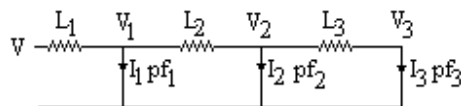

Draw the vectors V_3 and I_3 at $\text{Arc Cos}(\text{pf}_3)$, the angle between them

Draw the vectors $R L_3 I_3$ and $j X L_3 I_3$ to obtain V_2

Draw vector V_2 and I_2 at $\text{Arc Cos}(\text{pf}_2)$ relative to V_2

Complete the parallelogram to get vector $(I_2 + I_3)$

Draw vectors $R L_2 (I_2 + I_3)$ and $j X L_2 (I_2 + I_3)$ to obtain V_1

Repeat to obtain V

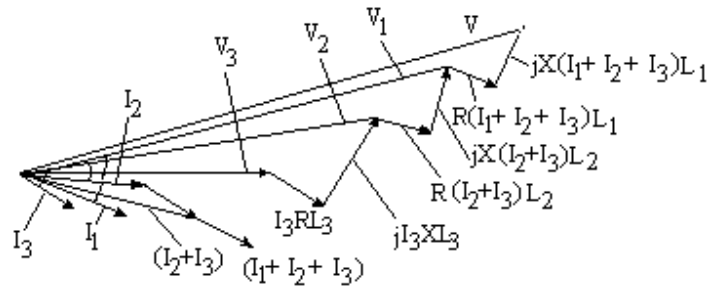

The volt drops are greatly exaggerated to show the construction. In practice the volt drop does not exceed a few per cent.

Example

A motor is taking a load of 10 amps at a power factor of 0.8 at 440 volt 50 Hz.

Find the size of condenser to be connected in parallel to bring the pf to unity.

Phase angle = Arc Cos (0.8) = 36.9° Wattless current = 10 Sin 36.9 = 6.0 amps

$X_C = 3183/C$ and $V = IX_C$ therefore $C = 3183/X_C = 3183 \times 6.0/440 = 43\mu F$

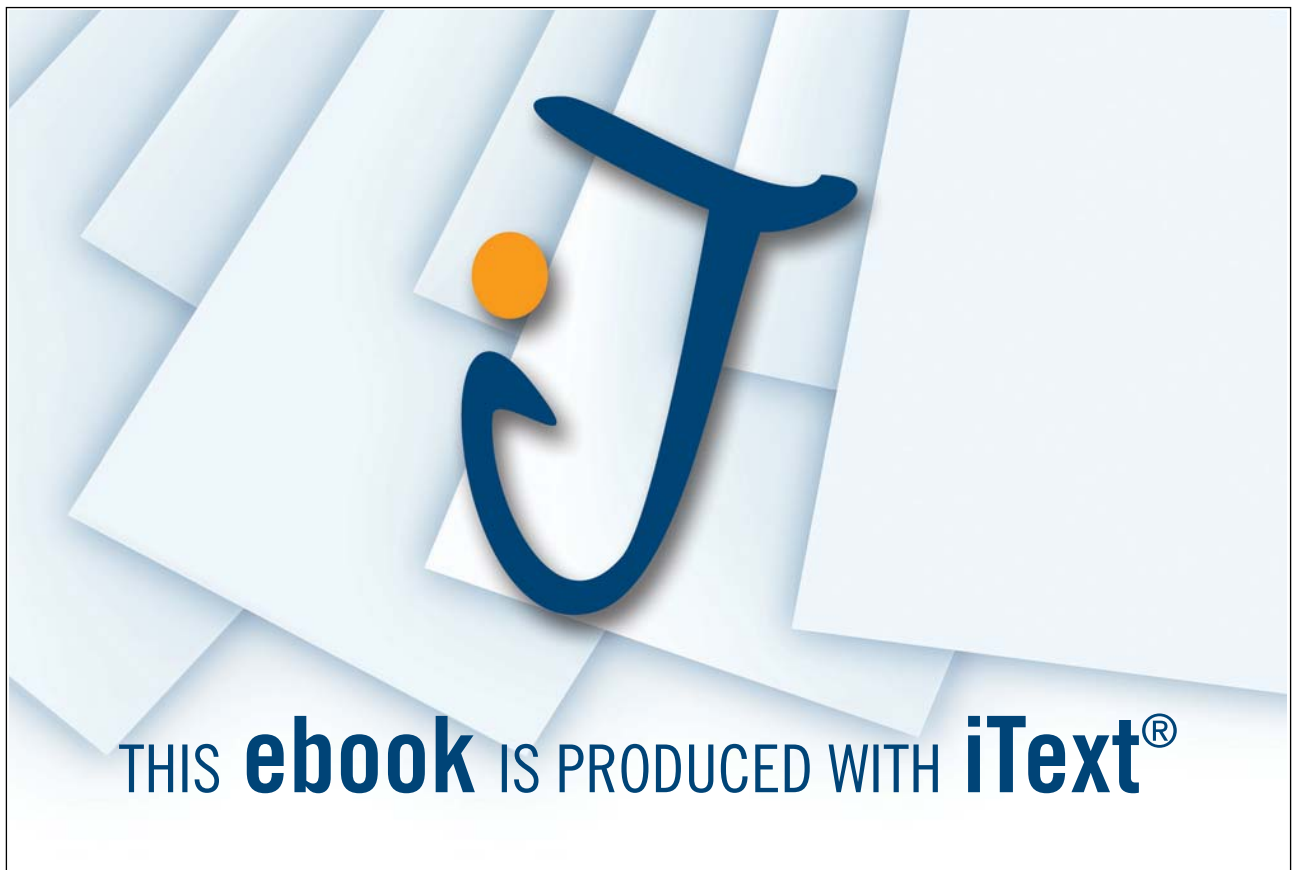

AC Bridge Circuits

AC Bridges

The total reactance X in each leg is the difference between the inductive reactance (+ ive) and the capacitive reactance (- ive)

For balance;

$$I_1 \cdot R_1 + j I_1 \cdot X_1 = I_2 \cdot R_2 + j I_2 \cdot X_2$$

And $I_1 \cdot R_3 + j I_1 \cdot X_3 = I_2 \cdot R_4 + j I_2 \cdot X_4$

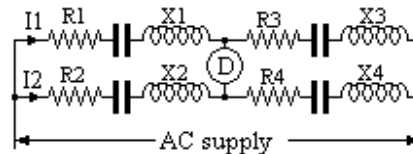

Hence $(R_1 + j X_1) / (R_3 + j X_3) = (R_2 + j X_2) / (R_4 + j X_4)$

And $(R_1 + j X_1) \cdot (R_4 + j X_4) = (R_2 + j X_2) \cdot (R_3 + j X_3)$

$$R_1 \cdot R_4 - X_1 \cdot X_4 + j(R_1 \cdot X_4 + R_4 \cdot X_1) = R_2 \cdot R_3 - X_2 \cdot X_3 + j(R_3 \cdot X_2 + R_2 \cdot X_3)$$

Equate real and imaginary terms

$$R_1 \cdot R_4 - X_1 \cdot X_4 = R_2 \cdot R_3 - X_2 \cdot X_3 \text{ and } (R_1 \cdot X_4 + R_4 \cdot X_1) = (R_3 \cdot X_2 + R_2 \cdot X_3)$$

These two conditions must be met for balance.

AC Bridge reactances both capacitive

(Reactances both inductive is similar)

When in balance (no current in D)

$$I_1 \cdot R_1 = I_2 \cdot (r_1 - jX_1)$$

$$I_1 \cdot R_2 = I_2 \cdot (r_2 - jX_2)$$

Hence

$$R_1 / R_2 = (r_1 - jX_1) / (r_2 - jX_2)$$

$$R_1 \cdot r_2 - j R_1 \cdot X_2 = R_2 \cdot r_1 - j R_2 \cdot X_1$$

Equate real and imaginary terms

$$R_1 \cdot r_2 = R_2 \cdot r_1 \quad \text{and} \quad R_1 \cdot X_2 = R_2 \cdot X_1$$

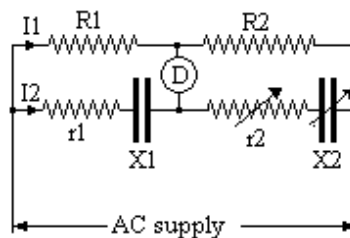

AC Bridge capacitive reactance balancing an inductive reactance

With no current through D

$$I_1 \cdot (P + jX_L) = I_2 \cdot R \text{ and } I_1 \cdot Q = I_2 \cdot (S - jX_C)$$

Hence $(P + jX_L)/Q = R / (S - jX_C)$

$$P \cdot S - j P \cdot X_C + j S \cdot X_L + X_L \cdot X_C = Q \cdot R$$

Equate real and imaginary terms

$$P \cdot S + X_L \cdot X_C = Q \cdot R$$

$$P \cdot X_C = S \cdot X_L$$

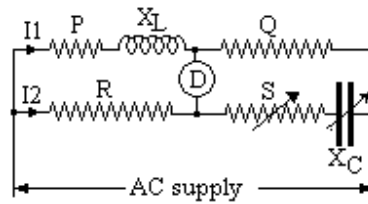

AC Bridge alternative arrangement

With no current through D

$$I_1 \cdot P + j I_1 \cdot X_L = I_2 \cdot R$$

$$I_1 \cdot Q = I_3 \cdot S = -j I_4 \cdot X_C$$

$$I_2 = I_3 + I_4$$

Hence $I_2 = [(P + j X_L)/R] \cdot I_1$

$$I_3 = (Q/S) \cdot I_1$$

$$I_4 = [Q/(-j X_C)] \cdot I_1$$

$$[(P + j X_L)/R] = (Q/S) + [Q/(-j X_C)]$$

Equate real and imaginary terms

$$P/R = Q/S \quad \text{and} \quad X_L/R = Q/X_C$$

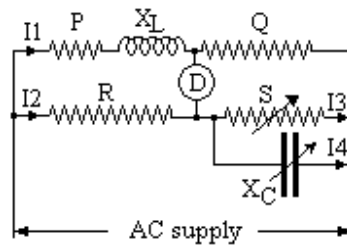

Bridge circuit to find R and L

$$I_1 \cdot (R + j\omega L) = I_2 \cdot [P - j/(\omega C)]$$

$$I_1 Q = I_2 \cdot [-j/(\omega K)]$$

$$(R + j\omega L) \cdot [-j/(\omega K)] = [P - j/(\omega C)] \cdot Q$$

$$-jR/(\omega K) + L/K = P \cdot Q - jQ/(\omega C)$$

Equate real and imaginary terms

$$L = P \cdot Q \cdot K \quad \text{and} \quad R = Q \cdot K / C$$

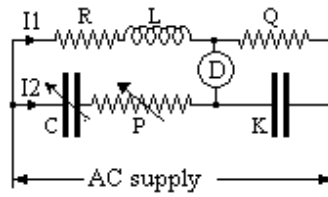

Note this result does not include ω , thus a buzzer which contains a multiple of sine waves can be used as the AC supply.

www.sylvania.com

We do not reinvent the wheel we reinvent light.

Fascinating lighting offers an infinite spectrum of possibilities: Innovative technologies and new markets provide both opportunities and challenges. An environment in which your expertise is in high demand. Enjoy the supportive working atmosphere within our global group and benefit from international career paths. Implement sustainable ideas in close cooperation with other specialists and contribute to influencing our future. Come and join us in reinventing light every day.

Light is OSRAM

OSRAM SYLVANIA



Magnetic Properties of Materials

B – H Curves

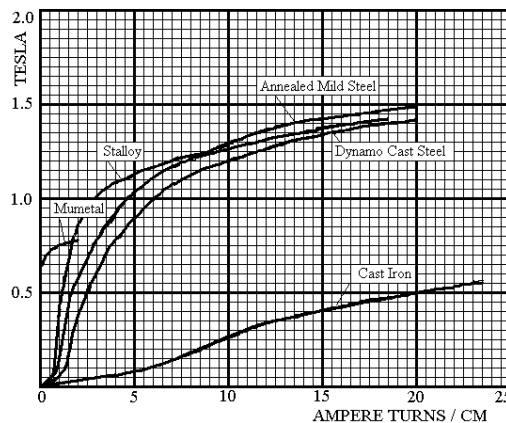

The graph shows typical B-H curves for some common magnetic materials.

The gradient near the origin is a measure of the permeability μ .

For many materials

$H = \alpha B^{1.6}$ in the range 0.5 to 1.2 tesla

$$\mu = B / H$$

where B is in tesla and $H = 1.26 \times (\text{NI/m}) \times 10^{-6}$

Hence

$$\mu = [B / \{1.26 \times (\text{Ampere Turns/cm})\}] \times 10^4$$

Thus for Dynamo Cast Steel, μ is about $[1 / (1.26 \times 5)] \times 10^4 = 1600$

Hysteresis

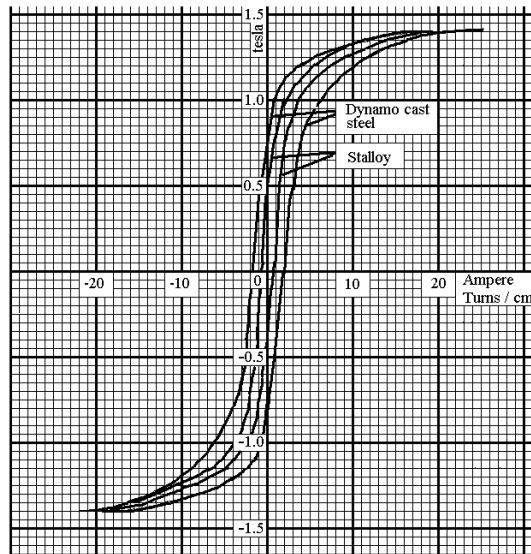

When a magnetic material is magnetized, it retains some magnetism when the magnetizing force is switched off. If H is raised from zero to a positive value then reduced to the same value negative and again to the positive, the magnetic field B lags behind the magnetising force. This is called the hysteresis loop. The area of the loop is a measure of work done in magnetizing the iron through this cycle.

The graph shows the hysteresis loops for Dynamo Cast Steel and for Silicon Iron (Stalloy). The Stalloy is the inner loop. As the area is a measure of the energy loss per cycle, the Stalloy has less energy loss per cycle than the Dynamo Cast Steel.

Flux Temperature relation

With a constant Magnetizing Force, the Flux rises slightly with Temperature till about 600 °C and then falls rapidly to zero at the Curie point.

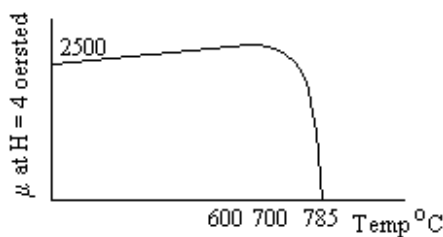

Energy spent in Hysteresis

Consider a laminated ring of the material, cross sectional area A cm² and circumference of the ring L cms. The ring has a coil of N turns taking a current i emu at time t.

$$H = 4\pi N i / L$$

(H in oersted, i in emu and L in cm)

Power taken = copper loss + loss in field

Loss in field = ei where e is the back emf

$$\text{But } e = -N d\Phi / dt = -N A dB / dt$$

Energy put into the field in time δt

$$= e i \delta t \text{ ergs}$$

$$= [N A dB / dt] H L / (4\pi N) \delta t$$

$$= (1/4\pi) H L A \delta B$$

Energy put into the field in element of time = $(1/4\pi) \cdot H \cdot L \cdot A \cdot \delta B$ ergs

Energy put into the field in finite time = $(1/4\pi) \cdot L \cdot A \cdot \int H \delta B$ ergs

$L \cdot A$ = volume of the core material in cc

$\int H \delta B$ over one cycle = area of the hysteresis loop

Hence Energy loss due to hysteresis = $(1/4\pi)$ (area of hysteresis loop) ergs / cycle / cc

where the hysteresis loop is in oersteds/cm and gauss

Let AT be the ampere turns / metre

AT / 100 is the ampere turns / cm

AT / 1000 is the emu of current turns / cm

H in oersted = 4π AT / 1000

Let F be the flux density in tesla

Flux density in gauss = 10^4 F

Area of the hysteresis loop in oersted and gauss = 4π AT F x 10

Hence Energy loss due to hysteresis

$$= (1/4\pi) (4\pi AT F x 10) \text{ ergs / cycle / cc}$$

$$= AT F x 10 x 10^6 \text{ ergs / cycle / cubic metre}$$

$$= AT F \text{ joules / cycle / m}^3$$

At frequency f cycles/sec

Power loss = f x (area of hysteresis loop) watts/ cubic metre

where the hysteresis loop is in tesla and ampere turns / metre

Example

Steel used for an armature has a B-H curve of area 4 sq ins for the relevant cycle. $B_{\max} = 1$ tesla. Scales 1"

= 2 oersted, 1" = 0.5 tesla

Find the approx hysteresis loss if stampings weigh 200 lb

Machine has 4 poles and runs at 600 rpm.

$$H = (4\pi/10) NI/cm = [(4\pi/1000) (\text{AmpTurns/metre})] \text{ oersted}$$

$$\text{Area of hysteresis loop} = 4 \times 2 \times 0.5 = 4 \text{ oersted} \times \text{tesla}$$

$$= 4 \times 1000 / (4\pi) (\text{Amp Turns/metre}) \times \text{tesla}$$

$$= 318.3 \text{ joules / cu metre}$$

Volume of steel = $200 \times 453.6 / 7.7$ cubic cms = 0.01176 cu metres

Cycles per sec = $2 \times 600 / 60 = 20$ cycles / sec

Hysteresis loss = $318.3 \times 0.01176 \times 20$ joules/sec = 74.9 watts

Energy in an electro-magnetic field in air

Let the current i amps be raised uniformly over T seconds from 0 to the final value I

The back emf during T is constant at $N \frac{d\Phi}{dt}$

$$E = - N \frac{d\Phi}{dt}$$

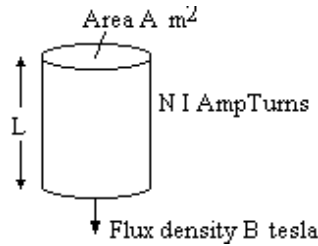

Energy input in joules during $T = \int E i dt$

$$= N(\Phi/T) \int i dt \text{ from } 0 \text{ to } T$$

$$= N(\Phi/T) \int (I t/T) dt \text{ from } 0 \text{ to } T$$

$$= N(\Phi/T) (I t^2/2T) \text{ from } 0 \text{ to } T$$

$$= N(\Phi/T) (I T^2/2T)$$

$$= NI \Phi / 2$$

CHALLENGING PERSPECTIVES



Internship opportunities

EADS unites a leading aircraft manufacturer, the world's largest helicopter supplier, a global leader in space programmes and a worldwide leader in global security solutions and systems to form Europe's largest defence and aerospace group. More than 140,000 people work at Airbus, Astrium, Cassidian and Eurocopter, in 90 locations globally, to deliver some of the industry's most exciting projects.

An **EADS internship** offers the chance to use your theoretical knowledge and apply it first-hand to real situations and assignments during your studies. Given a high level of responsibility, plenty of

learning and development opportunities, and all the support you need, you will tackle interesting challenges on state-of-the-art products.

We welcome more than 5,000 interns every year across disciplines ranging from engineering, IT, procurement and finance, to strategy, customer support, marketing and sales. Positions are available in France, Germany, Spain and the UK.

To find out more and apply, visit www.jobs.eads.com. You can also find out more on our **EADS Careers Facebook page**.









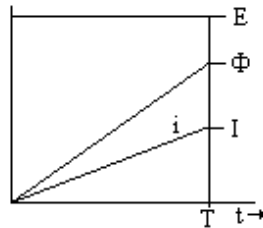

But in air, $B = (4\pi/10^7) NI / L$ and $\Phi = B A$
 where L metres is the length of path
 hence $NI = B L \times 10^7 / (4\pi)$
 Energy input = $[B L \times 10^7 / (4\pi)] B A/2$ joules
 $= B^2 \times 10^7 / (8\pi)$ joules per cubic metre



Energy stored in a uniform magnetic field in air = $B^2 \times 10^7 / (8\pi)$ joules per m^3
 where B is in tesla

Eddy Currents in laminated iron core all dimensions in metres

Consider an elemental path, distance x metres from the centreline and width δx in a flux density B tesla in a direction parallel to edge w .

emf induced in the loop $e = d/dt(B L 2x)$

Resistance = $2L \rho / (w \delta x)$ where ρ is ohms per metre cube

power loss = e^2 / R

$$= [d/dt(B L 2x)]^2 / (2L \rho / w \delta x)$$

$$= [(dB/dt)^2 2Lx^2 w / \rho] \delta x$$

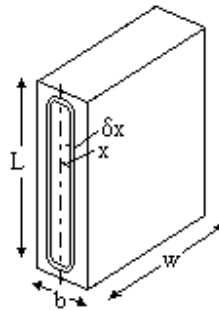

$$\text{total power loss} = [(dB/dt)^2 2L w / \rho] \int x^2 \delta x \text{ from } 0 \text{ to } b/2$$

$$= [(dB/dt)^2 2L w / \rho] (1/3) (b/2)^3$$

$$= (dB/dt)^2 L w / \rho] (1/12) b^3$$

Let $B = B_m \sin (2\pi f t)$

$dB/dt = B_m 2\pi f \cos (2\pi f t)$

Mean value of $(dB/dt)^2 = \frac{1}{2} (B_m 2\pi f)^2 = 2 \pi^2 f^2 B_m^2$

This is the loss in a volume Lbw

Power loss / cubic metre = $2 \pi^2 f^2 B_m^2 b^2 / (12\rho)$ metre = $\pi^2 f^2 B_m^2 b^2 / (6 \rho)$

Eddy current loss = $\pi^2 f^2 B_m^2 b^2 / (6 \rho)$ watts / cubic metre

where f is the freq, B_m is the maximum magnetic field in tesla, b is in metres and ρ is ohms/metre cube

Eddy current loss = $\pi^2 f^2 B_m^2 b^2 / (6 \rho)$ watts / cm³ where b is in cm and ρ is ohms/cm cube

Empirical formula

Iron loss = eddy current loss + hysteresis loss
 $= K_1 f^2 B^2 + K_2 f B^{1.6}$

where K_1 and K_2 are constants, f is the number of cycles / sec (or rps) and B is the flux density in the range 0.5 to 1.2 tesla.

K_2 depends on the material and is typically in range 500 – 5000 watts/cu metre

Electromagnet

Let A = total area of pole faces in contact in m², assume North and South faces are equal.

B = Flux density in the gap in tesla

z = air gap in metres

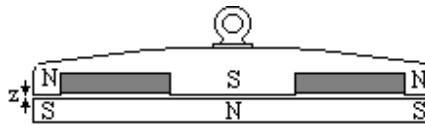

Let the gap be widened by δz metres and the current in the coil increased by δI to keep the flux density constant in the air gap.

There is no change in the flux turns linked with the winding.

Therefore no emf set up in the winding

Therefore no power change in the winding except for the I^2R loss.

In the non magnetic air gap,

energy stored = $B^2 \times 10^7 / (8 \pi)$ joules per cubic metre.

Increase in energy stored in the air gap = $(A \delta x) B^2 \times 10^7 / (8 \pi)$

This must have come from mechanical work done = $P \delta x$ joules

Hence Pull $P = B^2 \times 10^7 / (8 \pi)$ newtons per m²

where B is in tesla

Example

The total loss in a cylindrical core of steel stampings running at 400 rpm in a given field is 300 watts. At 600 rpm in the same field, loss is 525 watts. Estimate how much of loss at 400 rpm is due to hysteresis.

Let W_1 be hysteresis loss and W_2 be eddy current loss at 400 rpm

Then $W_1 + W_2 = 300$

At 600 rpm, $W_1 \times 600/400 + W_2 \times [600/400]^2 = 525$

$W_1 \times 400/600 + W_2 = 525 \times [400/600]^2 = 233$

$W_1 \times 1/3 = 300 - 233$

$W_1 = 200$ and $W_2 = 100$ watts

A new core is made of stampings 1.5 times the thickness, other dimensions unchanged. Estimate the iron loss in a flux density 20% higher and at 500 rpm.

New hysteresis loss = $200 \times (120/100)^{1.6} \times (500/400) = 335$ watts

$$\text{New eddy current loss} = 100 \times (120/100)^2 \times (500/400)^2 \times (1.5)^2 = 506$$

$$\text{Total loss} = 840 \text{ watts}$$

Example

At flux density B, the iron loss for Stalloy sheet 0.014" thick

at 50 Hz is 0.89 watts/lb and at 100 Hz is 2.17 watts/lb

Estimate the hysteresis loss at 50 hz and the total loss at 100 hz of 0.02" sheet

Let W1 be hysteresis loss and W2 be the eddy current loss at 50 hz

$$W1 + W2 = 0.89 \text{ watts/lb}$$

$$W1 \times (100/50) + W2 \times (100/50)^2 = 2.17 \text{ watts/lb}$$

$$W2 = (2.17 - 2 \times 0.89)/2 = 0.195 \text{ and } W1 = 0.89 - 0.195 = 0.695$$

New hysteresis loss = $0.695 \times (100/50) = 1.39$ watts/lb

New eddy current loss = $0.195 \times (100/50)^2 \times (0.02/0.014)^2 = 1.59$ watts/lb

Total loss = 2.98 watts/lb



360°
thinking.

Deloitte.

Discover the truth at www.deloitte.ca/careers

© Deloitte & Touche LLP and affiliated entities.



DC Motors and Generators

DC machines

DC Machines are usually built with the field magnetic circuit in the stator, through the Yoke, Pole Body and Pole Shoe. Field windings are round the pole body.

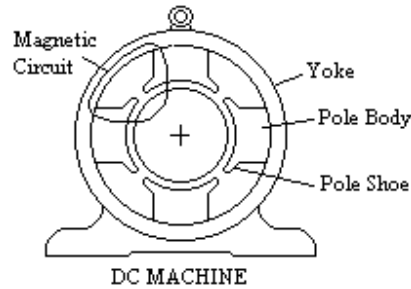

The rotor is made up of stampings, ie laminations of low hysteresis steel. Dynamo sheet steel is often used.

The armature windings are on the rotor and are put in slots on the laminated core and held in place by strips of insulating material. Each slot usually contains two layers, half a coil in each layer. The coil may be anything from a single conductor to a multitude of turns. The whole assembly is then impregnated with varnish to remove air and prevent any movement.

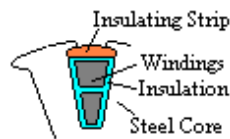

The rotor windings are connected to the commutator. The commutator is made with copper strips that have a wedge shaped cross section. These are stacked together with insulation between the strips. The assembly is clamped together onto the shaft between two discs each having a tapered flange. Each segment has a strip of copper or steel soldered in a slot in the segment to connect the segment to the windings.

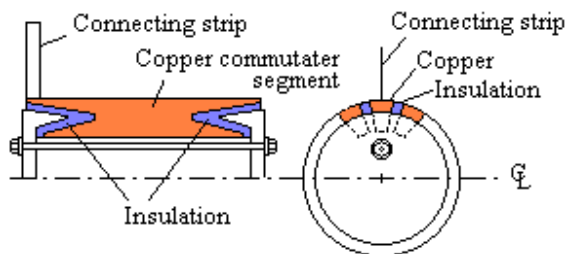

The connection to the commutator is by the “brushes”. These are carbon or graphite blocks spring loaded to rub against the commutator.

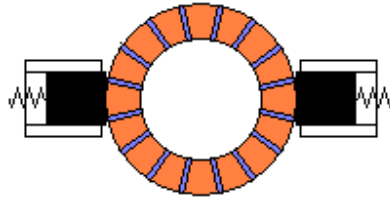

Output Coefficient

Output coefficient = kW / D²L x (rpm)

where D is the armature diameter and L is the armature Length

Output = E I watts ∝ B x πDL x Z_s x I x (rpm)

Output coefficient = kW / D²L x (rpm)

∝ [B x πDL x Z_s x I x (rpm)] / [D²L x (rpm)]

∝ B x Z_s x (I/D)

Output coefficient ∝ (flux density) x (ampere wires/cm)

SIMPLY CLEVER

ŠKODA



We will turn your CV into an opportunity of a lifetime



Do you like cars? Would you like to be a part of a successful brand? We will appreciate and reward both your enthusiasm and talent. Send us your CV. You will be surprised where it can take you.

Send us your CV on www.employerforlife.com



Back emf distribution

As one conductor moves past the pole face, an emf is induced in this conductor proportional to the flux density.

The armature contains many conductors in series spaced round the armature. The emf in each follows the same pattern. The total due to all the conductors in series is the mean value times the number of conductors.

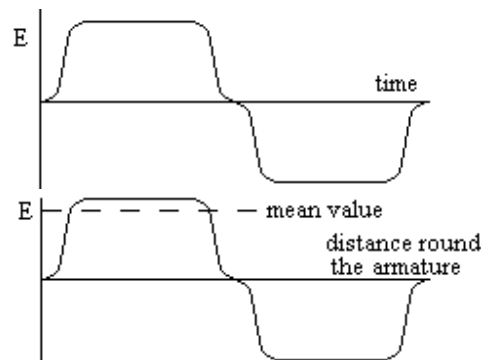
Total back emf.

In one revolution, each conductor on the rotor cuts the magnetic flux of each pole once. Poles are always in pairs, a North and a South pole.

Let there be p pairs of poles each with a magnetic flux Φ weber.

Therefore each conductor cuts $2p\Phi$ of magnetic flux in one revolution.

Assume that the conductor is connected to the commutator so that the emf generated is the same polarity under a North pole as under a South pole.

In one second, each conductor cuts a flux of $2p\Phi \times$ (revolutions per second).

Emf generated in one conductor = webers cut per second = $2p\Phi$ (rps)

Let there be Z_s conductors connected in series

Back emf = $2p \Phi Z_s$ (rps) volts

Power in a DC machine

Power = (back emf) \times (Armature Current)

Power = $E I_a$ watts

= $2p \Phi Z_s I_a$ (rps) watts

Torque of a DC machine

But Power in watts = (Torque in newton metres) \times (2π rps)

Torque = $2p \Phi Z_s I_a / (2\pi)$ newton metres

= $E I_a / [2\pi \times (\text{rps})]$ newton metres

= $0.117 \times 2p \Phi Z_s I_a$ lb ft

= $0.117 E I_a / (\text{rps})$ lb ft

DC Motor Shunt Connected

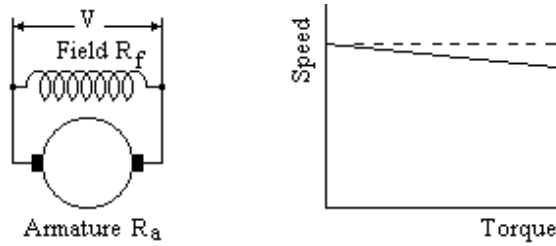

DC Shunt Motors have a field winding of many turns switched directly to the supply. The flux Φ is the flux due to the field current I_f where $I_f = V/R_f$.

V/R_f is constant, hence the flux Φ is constant.

In the armature circuit $V = E + I_a R_a$

hence the armature current is given by $I_a = (V - E) / R_a$

Substitute for E,

$I_a = (V - 2p \Phi Z_s n) / R_a$ where n is the speed in rps

$T = 2p \Phi Z_s I_a / (2\pi)$ where T is the Torque in newton metres

Thus (Output torque + torque due to losses) is proportional to I_a and Φ

Substitute for I_a ,

$T = 2p \Phi Z_s (V - 2p \Phi Z_s n) / (2\pi R_a)$

$[(2\pi R_a) / (2p \Phi Z_s)] T = V - 2p \Phi Z_s n$

$n = [V / (2p \Phi Z_s)] - [(2\pi R_a) / (2p \Phi Z_s)^2] T$

$n = n_0 - m T$

where n is the speed in rps and T is the input torque in newton metres

ie Torque = output torque + torque loss due to eddy currents, hysteresis, bearing friction, windage and brush friction.

and $n_0 = [V / (2p \Phi Z_s)]$ is the speed in rps when $T = 0$

and $m = [(2\pi R_a) / (2p \Phi Z_s)^2]$ is the gradient of the n - T curve

R_a is small, hence DC shunt motors run at nearly constant speed whatever the torque. They are used where a constant speed is required, eg to drive rolling mills, pit winding gear, machine tools etc.

DC Motor Series Connected

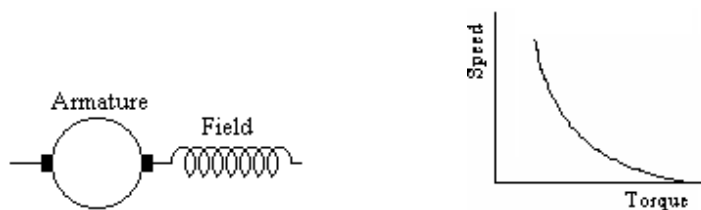

The DC series motor has a high current field winding in series with the armature.

Let the total resistance of armature and field be R ohms and the current be I amps.

Applied voltage $V = E + IR$

$$E = 2p \Phi Z_s \text{ (rps)}$$

$$\Phi = 4\pi N I / \Sigma[L / \mu A]$$

where $\Sigma[L / \mu A]$ is the sum of the several parts of the magnetic circuit

Put $4\pi N / \Sigma[L / \mu A] = K$

$$\Phi = K I \text{ and therefore } E = 2p K I Z_s \text{ (rps)}$$

$$\text{But } V - E = I R \text{ and } T 2\pi \text{ rps} = E I$$

$$V - I R = E = 2p K I Z_s \text{ (rps)}$$

$$V = I [R + 2p K Z_s \text{ (rps)}]$$

$$I = V / [R + 2p K Z_s \text{ (rps)}]$$

$$E = 2p K Z_s \text{ (rps)} V / [R + 2p K Z_s \text{ (rps)}]$$

$$T 2\pi \text{ rps} = E I = 2p K Z_s \text{ (rps)} V^2 / [R + 2p K Z_s \text{ (rps)}]^2$$

$$T = [2p K Z_s V^2 / 2\pi] / [R + 2p K Z_s \text{ (rps)}]^2$$

$$T = P / [1 + Q n]^2$$

Where P and Q are constants, $P = 2p K Z_s V^2 / (2\pi R^2)$ and $Q = 2p K Z_s / R^2$

T is the input torque in newton metres and n is rps

$$T [1 + Q n]^2 = P$$

I joined MITAS because
I wanted **real responsibility**

The Graduate Programme
for Engineers and Geoscientists
www.discovermitas.com





Month 16
I was a construction
supervisor in
the North Sea
advising and
helping foremen
solve problems

Real work
International opportunities
Three work placements







This is a hyperbola of $[1 + Q n]^2$ against T

The starting torque ($n = 0$) is $T = 2p K Z_s V^2 / (2\pi R^2)$

On light load, (ie T nearly zero) n is very high.

DC Series Motors have a high torque at low speed which makes them suitable for traction motors or starter motors for petrol and diesel engines.. They are not suitable for applications where they may be run without load as they may overspeed.

DC Compound Connected

A combination of Series and Shunt fields can give an alternative Speed/Torque relationship. For example, a shunt motor with a few turns on the field series connected in opposition to the shunt field can give a truly constant speed whatever the torque.

Armature Reaction

The current in the armature of a DC machine causes a magnetising force in a direction between the pole faces. This increases the magnetising force on part of the pole and reduces the magnetising force on the other part by the same amount. Due to saturation of the field magnetic circuit, the increase in flux in part of the pole is less than the decrease in the other part of the pole. Thus the effect of armature reaction is to give an overall reduction in flux. The magnetic field across the pole face is distorted and the neutral point is moved.

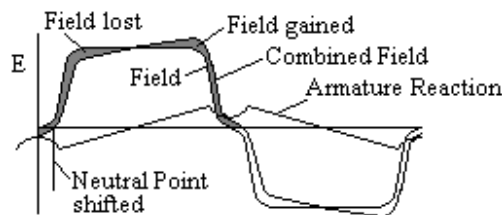

The effect can be reduced by;

- (i) Compensating windings on the stator connected in series with the armature. These are connected to give a field in opposition to the armature reaction. They can be installed on the pole face close to the armature conductors to almost completely eliminate armature reaction.
- (ii) A deep slot in the pole face that puts an air gap in the field due to armature reaction but not in the main field.
- (iii) Increased air gap on pole face.

Compensating Winding

Compensating windings are additional windings on the field that are connected in series with the armature and exactly oppose the armature reaction.

Interpoles

The current reversal is impeded by the self inductance of the winding. Lenz's law means that the change is opposed. Large DC Motors often have Interpoles. These are small poles, connected in series with the armature, sited between the main poles. Their purpose is to induce a voltage in the winding when the current reversal occurs. This voltage is arranged to oppose the self induced emf and assist the current reversal.

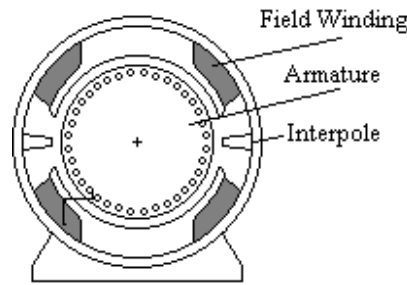

The brush short circuits each coil as the commutator passes the brush. Without the interpole, the current decays exponentially.

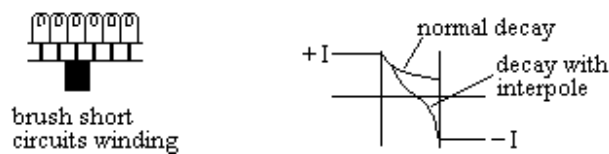

The interpole increases the decay and induces a current in the opposite direction. If L henries is the self inductance of the coil and T seconds is the time it is short circuited, then the interpole must induce an emf of $2IL/T$ volts.

For good commutation, the interpole winding is connected in series with the armature and has a large air gap to reduce the effect of saturation.

The self inductance of the coils can be reduced at the design stage by more commutator bars and more slots and fewer turns. Higher resistance brushes help as do wider brushes which increase the overlap. Without interpoles, moving the brush position so the coil picks up some of the main field can reduce sparking but a different position is needed for a different load.

If the voltage induced by the interpoles is too high, moving the brush position will reduce it. Altering the interpole air gap by packing behind the pole or by machining the face will increase or reduce the induced voltage

The effect of an interpole is not dependent on speed or load or on whether the machine is acting as a motor or generator.

The interpole windings oppose armature reaction, but the interpole introduces a magnetic path for the armature reaction mmf. Thus the interpole does not eliminate armature reaction and may even increase it.

Example

A DC Generator has coils with estimated self inductance $L = 8E-6$ henries and resistance 0.001 ohms. From the speed of rotation and brush and commutator dimensions, it is calculated that the coil is short circuited for 0.001 secs. Armature current = 180 amps.

$$I = 180 e^{-R/L t} = 180 e^{-(1/8)} = 0.882 \times 180 = 159$$

Average volts required = $L \, di/dt = 8E-6 \times 2 \times 180 / 0.001 = 2.88$ volts

Introduce 2.88 volts by interpoles, then $-L \, di/dt - e = iR$

$-8E-6 \, di/dt - 2.88 = 0.001 \, i$

Solving, $i = 180$ at $t = 0$ and $i = -172$ at $t = 0.001$

Example

A 4 pole lap wound generator has 516 conductors and the length of the interpole air gap is 0.4 cms. The maximum flux density under the interpole is to be 0.2 tesla when the armature current is 30 amps.

Estimate the turns on each interpole.

Number of conductors under one main pole is $516/4 = 129$

Number of armature paths number of poles = 4

Current in each armature conductor = $30/4 = 7.5$

$$\int H \, dl = (2000 \times 0.4) \times 2 \text{ poles} + 0$$

$$= (4\pi/10) \{ N \times 30 \times 2 - (516/4) \times (30/4) \}$$

$$60 N = 1273 + 968$$

$$N = 37$$

ie 16 turns to combat armature reaction + 21 turns to give required mmf

"I studied English for 16 years but...
...I finally learned to speak it in just six lessons"

Jane, Chinese architect

ENGLISH OUT THERE

Click to hear me talking before and after my unique course download

Example

6 pole 200 kW 500 volt generator 550 rpm, armature winding 75 cms diameter, active length 20 cms, simple lap winding of full pitch and 880 conductors, 2 turns / commutator bar (ie 220 segments). Calculated reactance volts at full load = 4.5 volts. Find mean flux density under an interpoleat full load (assume uniform). Interpole air gap is 0.5 cms. Find turns required on each interpole.

Output amps = $200 \times 1000 / 500 = 400$ amps

4.5 volts is to be generated in 2 x (4 conductors of short circuit coil)

But emf = (short circuit turns) x (swept area/sec) x (flux density)

$$E = 4 \times (\pi D \times L \times \text{rps}) \times B$$

$$= 4 \times (\pi 75 \times 20 \times 550/60) / 10^4 \times B$$

$$B = 0.26 \text{ tesla}$$

$$\int H dl = 2600 \times 0.5 \times 2$$

$$= (4\pi/10) [\text{amps} \times N \times 2 - (\text{number of cond/pole}) \times (\text{amps/path})]$$

$$= (4\pi/10) [400 \times N \times 2 - (880/6) \times (400/6)]$$

$$800N = 880 \times 400 / 36 + 2600 \times (10/4\pi)$$

$$N = 12.2 + 2.6 = 15$$

(12.2 turns to balance armature reaction + 2.6 turns to give voltage)

Armature Windings

Armature windings can be Lap Wound or Wave Wound.

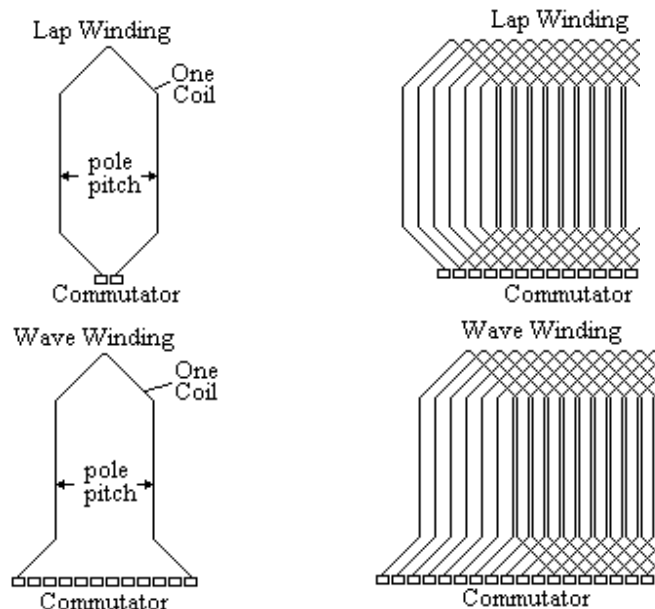

With a Lap winding,

$$Z_s = (\text{total number of conductors}) / (\text{number of poles})$$

With a Wave winding, $Z_s = (\text{total number of conductors}) / 2$

Other types of winding

i) Gramme Ring

The armature for this type of winding is a tube with spokes to the shaft. The winding is wound round and through the tube by hand secured in shallow slots. One end of the winding is bare and the brushes bear directly on the winding.

ii) Singly re-entrant winding

iii) Doubly re-entrant

iv) Duplex winding

Example

8 pole dynamo has $\Phi = 0.04$ weber and is to generate 220 volt at 250 rpm

Find a suitable number of conductors for a wave winding

Emf equation $E = (2p) \Phi Z_S \times (\text{rps})$

$$220 = 8 \times 0.04 \times Z_S \times 250/60$$

$$Z_S = 165$$

Wave winding, therefore number of conductors = $2 \times Z_S = 330$ conductors

If the coil sides are numbered as usual and pitches (measured in coil sides) are a_1 and a_2 , both a_1 and a_2 must be odd numbers and $(a_1 + a_2)$ must be even.

Hence with 8 poles, $4(a_1 + a_2) = Z_S \pm 2$

$$Z_S = (\text{a multiple of } 8) \pm 2$$

Nearest value for $Z_S = 170$

Hence total number of conductors = 340



WHILE YOU WERE SLEEPING...

www.fuqua.duke.edu/whileyouweresleeping

DUKE
THE FUQUA
SCHOOL
OF BUSINESS



Bearings

The bearings for small motors are in the end covers. Large motors usually have separate pedestal bearings. The motor end covers are then in two halves bolted together. This allows the windings to be inspected without disturbing the rotor.

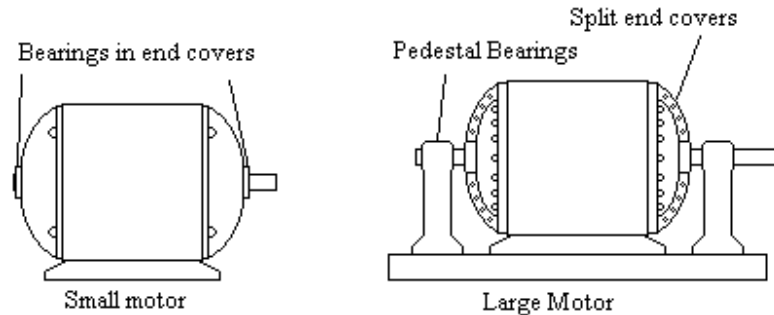

Starter for a DC motor

A DC motor will take a very large current if switched directly onto the supply. A series resistance is nearly always required to limit the current until the motor is spinning fast enough to generate back emf.

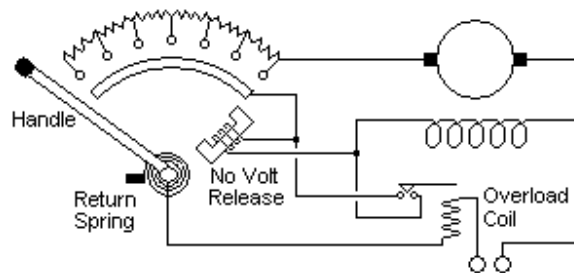

The diagram shows a typical spring loaded starter. The handle is moved manually against the spring over contacts sequentially cutting out the resistance. Finally when all resistance has been cut out, the handle comes up against a solenoid carrying field current. If the supply to the field fails, the handle is released and swings back to switch off the armature current.

The maximum current during starting is typically 150% full load current but for large motors may be as low as 110%. The starting resistors are only in use for a short time during starting and only need to be rated for this short time. Repeated attempts to start can overheat and damage the resistors.

The resistors typically consist of a stack of iron castings of a zig-zag shape as shown.

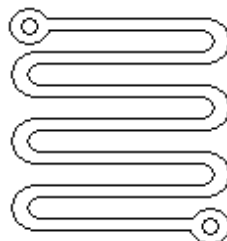

Example

Find the number and value of starting resistors for a DC shunt motor rated for 440 volts 100 amps full load. The armature resistance is 0.14 ohms and the current is to be limited to 150 amps during starting.

The initial total resistance of the armature circuit is $440/150 = 2.93$ ohms

When the current falls to 100 amps, the volt drop across the resistance of the armature circuit falls to $100 \times 2.93 = 293$ volts

As the next stage is switched in, the back emf remains the same so the voltage applied to the armature resistance remains at 293 volts

Total resistance at the next stage = $293 \text{ volts} / 150 \text{ amps} = 1.95$ ohms.

When the current falls to 100 amps, the IR drop falls to 195 volts

Total resistance at next stage = $195 / 150 = 1.30$ ohms

Similarly, the total resistance of the following stages are 0.87 ohms, 0.58 ohms, 0.39 ohms, 0.26 ohms, 0.17 ohms and 0.11 ohms.

The armature resistance is 0.14 ohms, therefore no added resistance is needed for the last stage.

Subtracting the armature resistance, the starter resistance at each stage becomes 2.79 ohms, 1.81 ohms, 1.16 ohms, 0.73 ohms, 0.44 ohms, 0.25 ohms, 0.12 ohms, 0.03 ohms and finally zero.

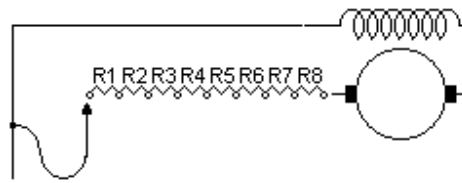

R1 = 0.98	R2 = 0.65
R3 = 0.43	R4 = 0.29
R5 = 0.19	R6 = 0.13
R7 = .09	R8 = 0.03

Speed control of DC shunt motors.

i. Field control

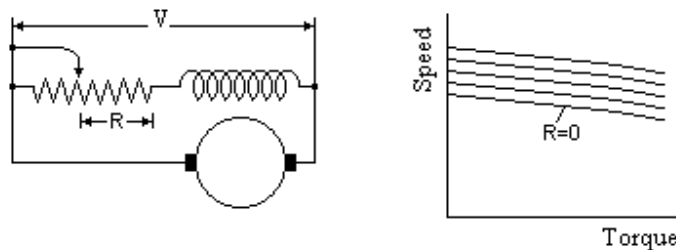

Speed control of a DC shunt motor is usually achieved by a variable resistance in the field circuit. The resistance increases the motor speed and cannot be used to give a low speed.

ii. Armature Resistance control

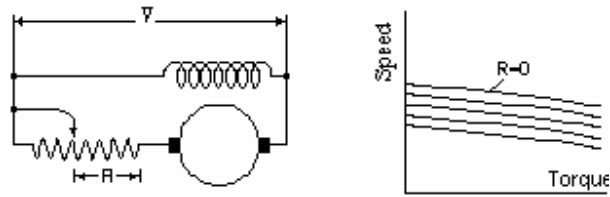

A resistor in the armature circuit reduces the speed but is very wasteful of energy.

iii. Armature shunt control

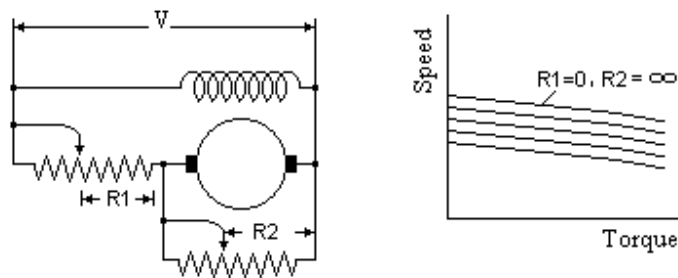

This is better and gives more stable speed control but is equally wasteful.

Excellent Economics and Business programmes at:



**university of
groningen**



**“The perfect start
of a successful,
international career.”**

CLICK HERE
to discover why both socially
and academically the University
of Groningen is one of the best
places for a student to be

www.rug.nl/feb/education



iv. Ward Leonard set

The motor generator set rotates at constant speed but the generator excitation can be varied. The final motor can have a fixed field but the voltage to the armature is variable. Speed control over a 25:1 ratio is possible.

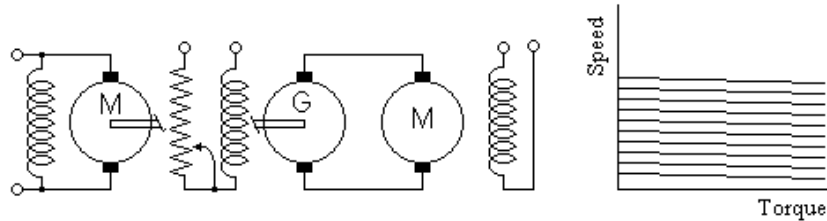

Ship propulsion systems often have a diesel electric drive. The diesel drives a generator directly connected to DC electric propulsion motor. This avoids the need for a gearbox or mechanical reverse gear and allows the diesel to be installed in the most suitable place on the ship.

Rolling Mill motors are usually Ward Leonard sets. The generator has a very large flywheel which stores up energy till the ingot reaches the rollers. Thus very high power is available for the short period of time that the ingot passes through without taking a high intermittent power from the electricity supply. Furthermore a severe overload can be tripped by circuit breaker before damage is done to the drive mechanism.

Speed control of a DC series motor

i. Series resistor

The speed of a DC series motor can be controlled by switching additional resistance in series. This in effect operates the motor on a reduced voltage.

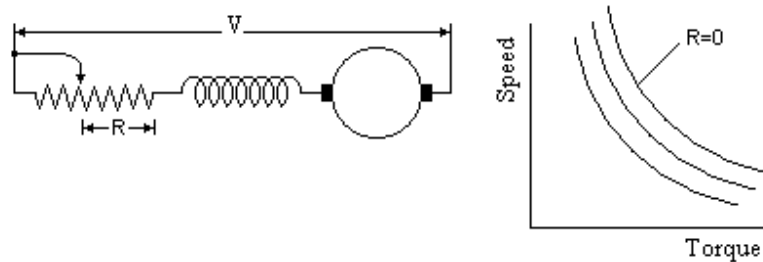

ii. Diverter resistor

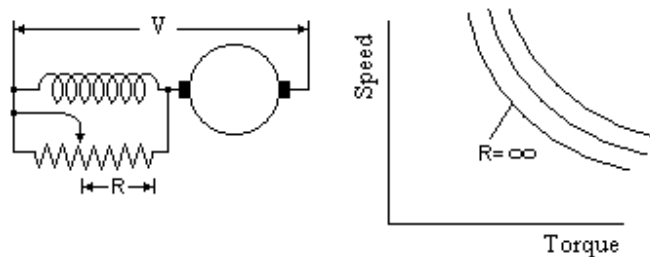

A diverter resistor allows higher speeds but is wasteful of energy.

iii. Series / parallel

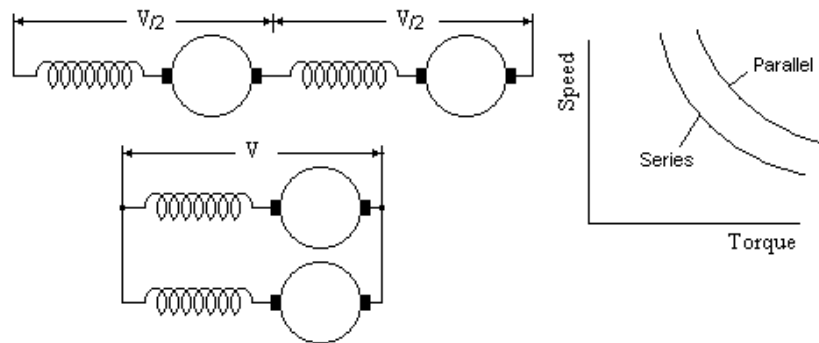

If two or more SC series motors are in use, then they can be switched between series and parallel connection giving two modes of operation.

Drum Controller

Electric trams usually have series motors which are controlled by a drum type controller. As a handle on top of the drum is rotated, a wiper moves across the contacts cutting out the series resistance in steps giving speed control. The controller usually incorporates a blow out coil. This coil carries the motor current giving a powerful magnetic field that acts on any arcing at the contacts drawing out the length of the arc and helping to extinguish it.

More sophisticated systems use two motors. At low speeds, the motors are connected in series then at a higher speed, they are switched into parallel operation.

Speed control resistances must be continuously rated and consume a lot of power when they carry armature current.

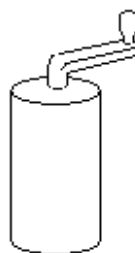

Forward/Reverse Control of a small series motor

Forward and reverse control of a conventional series or shunt motor requires a changeover switch to change both connections to the field in addition to the start/stop control.

If however the field winding is made twice the size with the centre connected to the armature, a single switch to either end starts the motor in forward or reverse. This is a popular arrangement for small motors such as the motor controlling the set point of a mechanical governor.

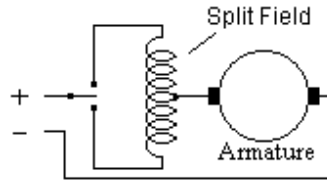

DC Shunt generator on no load

The output voltage of a DC shunt generator depends on the field strength. This depends on the output voltage and field resistance. If the field is supplied from another DC source, the voltage will follow the saturation curve for the magnetic circuit since V is proportional to the flux.

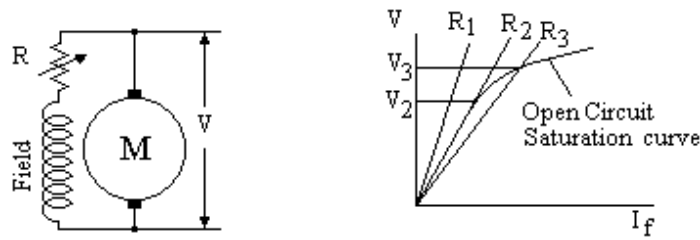

Thus if the field resistance is R_1 in the diagram, then the voltage will be only that due to the residual flux, ie nearly zero. If the resistance is reduced to R_2 , the voltage will rise suddenly to V_2 . Further reduction in field resistance to R_3 will cause the voltage to rise to V_3 .

Thus R_2 is the critical resistance, any resistance above this and the output voltage will be zero.

.....Alcatel-Lucent

www.alcatel-lucent.com/careers

What if
you could
build your
future and
create the
future?

One generation's transformation is the next's status quo. In the near future, people may soon think it's strange that devices ever had to be "plugged in." To obtain that status, there needs to be "The Shift".



DC Shunt generator on load

Neglecting armature reaction and brush drop

$$V = E - I_a R_a = I_f R_f$$

$$E = I_f R_f + I_a R_a$$

Thus for given I_a , the relation between E and I_f is linear.

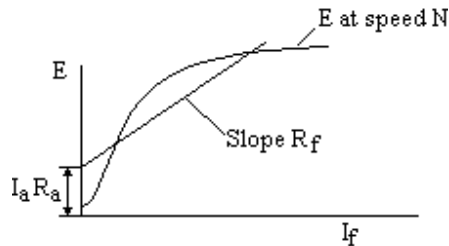

- A shunt generator will fail to excite if;
 - The field resistance is above the critical value
 - The speed is too low
 - There is no residual magnetism
 - The field connections or rotation are reversed
 - If the machine is run up with load resistance too low

DC Series generator



If R is the resistance of the armature plus field and R_L is the load resistance
 Then $E = I (R + R_L)$ This can be plotted by reducing R_L from above the critical value.

- The generator will not excite if;
 - The total resistance is above the critical value
 - The speed is too low
 - There is no residual magnetism
 - The field connections or rotation are reversed

DC Shunt Generators in parallel

Shunt generators will run in parallel.

With one generator on load, start the second and run up to rated speed. Close the field switch and adjust the voltage to exactly match the voltage on the running set.

Close the armature switch and increase the field current to put the set on load. Reduce the field on the first set as the field is increased on the second keeping the voltage at the correct value. Repeat step by step till the armature currents are balanced.

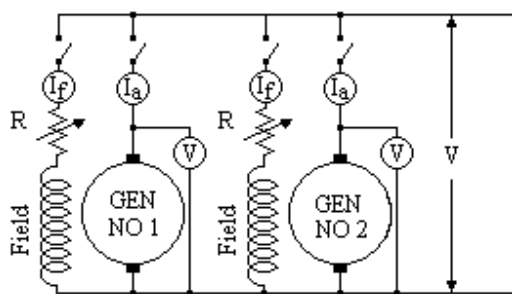

The load can be balanced between the generators either by adjusting the field resistors or by adjusting the speed of the prime movers.

DC Series Generators in parallel

DC series generators will not run in parallel unless there is an equalising connection between the fields. The equalising connection must be of low resistance for stable operation.

DC Compound Generators in parallel

An equalising bar of lower resistance than the series winding is required for stable operation. With No 1 machine on load, run up No 2 set to speed and adjust the voltage by the shunt regulator. Close No 2 machine armature switch and the equalising bar switch. Balance the loads by the shunt regulators keeping the voltage constant.

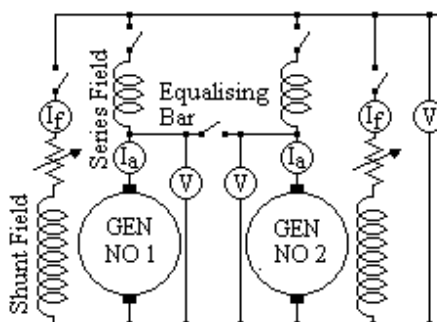

Example

The field of two DC shunt generators are adjusted to give a voltage of 520 volts on no load. The voltage of one generator on its own falls to 500 volts at 400 amps load. The voltage on the other generator falls to 490 volts on 400 amp load. Find the voltage with the generators in parallel and a total load of 500 amps.

At a current I_1 on machine 1, voltage $V_1 = 520 - 20 \times I_1/400$

At a current I_2 on machine 2, voltage $V_2 = 520 - 30 \times I_2/400$

When the machines are in parallel, $V_1 = V_2$

$$520 - 20 \times I_1/400 = 520 - 30 \times I_2/400$$

$$20 I_1 = 30 \times I_2$$

$$I_1 + I_2 = 500 \text{ amps}$$

$I_1 = 300$ amps and $I_2 = 200$ amps

$V = 520 - 20 \times I_1/400 = 520 - 20 \times 300/400 = 505$ volts

Motor and generator losses

- 1) Field copper loss is $I_f^2 R_f$ which depends on field current but not the speed
- 2) Bearing friction loss is dependent on speed but not the load.
- 3) Brush friction loss is dependent on speed but not the load
- 4) Windage losses are dependent on the speed but not the load.
- 5) Eddy current losses are dependent on the magnetic flux and speed but not the load.
- 6) Hysteresis losses in the armature is dependent on the magnetic flux and speed but not the load.
- 7) The armature loss is $I_a^2 R_a$ which depends on the load.

Swinburne's test to calculate the efficiency

This test enables the efficiency of the motor to be calculated without the need to put the motor on load. For this test, the field is supplied separately through a variable resistance.



Maastricht University

Leading in Learning!

Join the best at the Maastricht University School of Business and Economics!

Top master's programmes

- 33rd place Financial Times worldwide ranking: MSc International Business
- 1st place: MSc International Business
- 1st place: MSc Financial Economics
- 2nd place: MSc Management of Learning
- 2nd place: MSc Economics
- 2nd place: MSc Econometrics and Operations Research
- 2nd place: MSc Global Supply Chain Management and Change

Sources: Keuzegids Master ranking 2013; Elsevier 'Beste Studies' ranking 2012; Financial Times Global Masters in Management ranking 2012

Maastricht University is the best specialist university in the Netherlands (Elsevier)

Visit us and find out why we are the best!
Master's Open Day: 22 February 2014

www.mastersopenday.nl

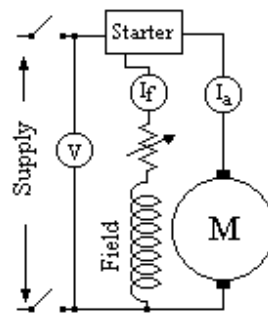

The armature and field resistances R_a and R_f are measured with the motor at rest. The motor is started and run up to the design speed on no load.

The Voltage, I_f and I_a are measured.

On no load, the losses equal the input

The total input power, $V (I_a + I_f)$ watts.

The friction, windage and iron loss = $V I_a - I_a^2 R_a$ watts

The field loss = $V I_f$ watts

The armature copper loss = $I_a^2 R_a$ watts

Let W = the sum of the friction, windage, iron and field loss

= $V I_a - I_a^2 R_a + V I_f$ watts

For a given speed, W is assumed to be constant as load is applied. (This is not exactly true since, at constant field, the speed falls slightly with load.)

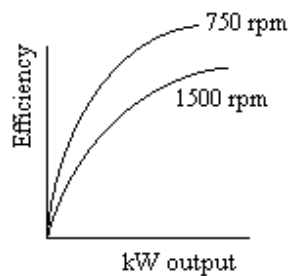

At any other armature current I_a , the loss = $W + I_a^2 R_a$ watts

The power input = $V (I_a + I_f)$ watts

The power output = power input – losses

= $V (I_a + I_f) - W - I_a^2 R_a$ watts

Efficiency = (power output) / (power input)

Thus the efficiency can be plotted against power output for this speed.

The no load test can be repeated at other speeds to obtain a family of curves of efficiency against power output at various speeds.

Swinburne’s test allows the efficiency to be calculated without having to measure the mechanical output. The efficiency is plotted against output at given speeds.

It is not exact as the speed and field cannot both be kept constant as the load is applied but is accurate enough for most practical purposes.

Swinburne's test does not test the motor or generator for other possible faults eg inadequate cooling, inadequate mechanical strength.

Hopkinson-Kapp test

When a batch of identical DC shunt motors are made, their performance can be found by the Hopkinson test. Two machines are coupled together on a common bedplate so that one machine drives the other which acts as a generator.

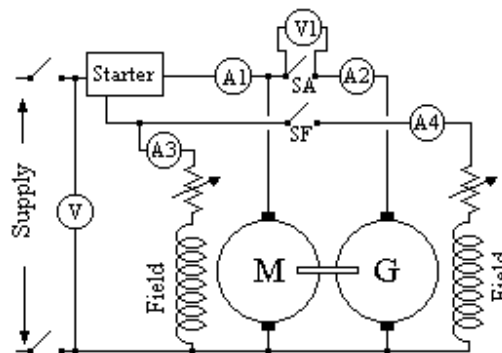

The generator output is fed back into the motor so the only power taken from the supply is to cover the losses.

The armature resistance R_m and R_g of the motor and generator are measured at standstill.

Choose a selection of speeds throughout the range. Start the motor through its starter and run up to each chosen speed with switches SA and SF open.

Tabulate A1 and A3 and $W1 = V \times A1$ for each speed.

$W1$ is the friction and windage loss of both machines plus the iron loss of the motor.

Close switch SF.

At each speed, adjust the generator field till $V1$ is zero and tabulate A1, A3, A4 and $W2 = A1 \times V$.

$W2$ is the friction and windage loss of both machines plus the iron loss of both machines. Hence at each speed the iron loss for one machine is $(W2 - W1)$ and the friction and windage loss of each machine is $\frac{1}{2}(2W1 - W2)$.

The brush friction loss of the generator can be found by measuring the power loss with the brushes in place and repeating the measurement with the generator brushes lifted but all other conditions identical. Choose a selection of armature currents between zero and full load rating.

At each speed, adjust the generator field till $V1$ is zero and close switch SA.

Adjust the generator field to give the selected armature current.

Tabulate the speed, V , A1, A2, A3, A4, $V \times A3$ (the field loss of the motor), $V \times A4$ (the field loss of the generator), $V \times A1$ (the total friction, windage, iron and armature loss of the two machines), $(A1 + A2)^2 R_m$ (the armature copper loss of the motor) and $(A2)^2 R_g$ (the armature copper loss of the generator).

Let W_3 be any loss unaccounted for (two machines)

$$W_3 = \text{total} - \text{friction \& windage loss (2 machines)} - \text{iron loss (2 machines)} \\ - \text{copper loss motor} - \text{copper loss generator}$$

$$W_3 = V \times A_1 - (2W_1 - W_2) - 2(W_2 - W_1) - (A_1 + A_2)^2 R_m - (A_2)^2 R_g$$

$$\text{Motor input} = V \times (A_1 + A_2 + A_3)$$

Let total motor loss be W_4

$$= \text{field loss} + \text{friction \& windage loss} + \text{iron loss} + \text{motor copper loss} + \frac{1}{2} W_3$$

$$W_4 = (V \times A_3) + \frac{1}{2} (2W_1 - W_2) + (W_2 - W_1) + (A_1 + A_2)^2 R_m + \frac{1}{2} W_3$$

$$\text{Motor output} = \text{motor input} - \text{motor loss} = V \times (A_1 + A_2 + A_3) - W_4$$

$$\text{Efficiency} = \text{motor output} / \text{motor input}$$

Hence a family of curves of efficiency, input and each of the losses can be drawn against output for each speed.

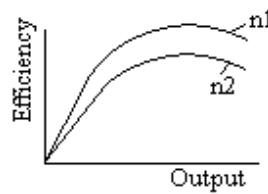



> Apply now

REDEFINE YOUR FUTURE
AXA GLOBAL GRADUATE
PROGRAM 2014

redefining / standards 



The motor and generator operate up to full load while taking a fraction of this power from the supply. Thus the machines can be tested and run for extended periods on full load in a location where the supply is inadequate to provide full load power, eg to measure the rise in the winding and bearing temperatures.

Deceleration tests

In this test, the weight and dimensions of a heavy flywheel are measured and the moment of inertia is calculated. The flywheel is fitted on the output shaft of a motor and the motor run up to speed. The motor is switched off and the speed is plotted against time as the motor slows down.

The test is repeated with a different flywheel.

At a given speed, the slope $d\omega/dt$ of each curve is measured.

(flywheel inertia + motor inertia) \times ($- d\omega/dt$) = torque due to losses

$$(I_1 + \text{motor inertia}) \times (-d\omega_1/dt) = (I_1 + \text{motor inertia}) \times (-d\omega_1/dt)$$

$$\text{motor inertia} = [I_1 \times (d\omega_1/dt) - I_2 \times (d\omega_2/dt)] / [(d\omega_1/dt) - (d\omega_2/dt)]$$

Loss in watts = (Torque in newton metres) \times 2π \times rps

Hence the friction and windage loss can be plotted against speed.

The test is repeated with the field energised during deceleration. The additional loss is the iron loss due to eddy currents and hysteresis.

Example

A torque of 2 ft lb will just keep the armature of a motor turning. With the field fully excited, the power required to keep the motor spinning at 600 rpm is 250 watts. The time taken to stop from 600 rpm is 30 sec with the field fully excited and armature open circuited.

Show the moment of inertia of armature is 38 lb ft²

At 600 rpm, power = 250 watts

Torque = power / speed = (250 \times 550) / (746 \times 20 π) = 2.93 ft lb

$T = \alpha + \beta\omega$ where $\alpha = 2$ ft lb and $\beta = 0.93/(20\pi)$

$K d\omega/dt = -g(\alpha + \beta\omega)$

$\int [K / (\alpha + \beta\omega)] d\omega$ from 20π to 0 = $-g \int dt$ from 0 to t

$K / \beta [\ln(\alpha + \beta\omega)]$ from 20π to 0 = $-g t$

$K = \beta g t / [\ln \{ (\alpha + 20\pi\beta) / \alpha \}] = 37.5 \text{ lb ft}^2$

[This assumes all the iron loss is hysteresis loss. What about eddy current loss which is proportional to ω^2]

Brush Drop

There is a voltage drop across the brushes, which is slightly different at the positive and negative brushes.

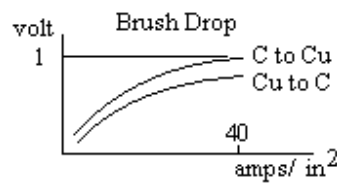

At current densities of 40 amps/sq in or more, the Carbon to Copper drop is about one volt and the Copper to Carbon drop is a little less. At lower current density, the drop is lower, almost zero at a small current. The drop depends on the type of brush, the state of the commutator and on the brush pressure and to a less extent on speed.

Brush position

The voltage of a DC generator follows a sine wave as the brush angle is moved through the position for the maximum. Thus the exact setting is difficult to find due to the flat response near the maximum. If however an AC voltage is applied to the field, the AC output at the brushes passes through zero as the brush angle is changed. This allows the neutral position to be set more accurately. In practice, rather than AC, a DC current is used and the kick of a voltmeter noted when the current is switched off. This is called the “kick test”. The best position for the brushes may be to one side of this neutral position due to self inductance of the armature which delays the current reversal.

Example

A 4 pole 75 kW, 525 volt, 750 rpm DC Generator is to be designed.
Flux per pole 0.0422 weber.

Armature OD 43.5 cms, ID 16.5 cms, length 22 cms and 3 vent ducts 0.75 cms
Net length of iron = [22 – 3 x 0.75] x 0.89 packing factor = 17.4 cms

Magnetic circuit

Part	Material	Length	Section	Flux	B (tesla)	H	HL
Core	Dynamo sh steel	20 cms	165 cm ²	0.0211	1.28	10	200
2 teeth	Dynamo sh steel	2x4	102.5	0.0211	2.06	280	2240
Air gaps	Air	2x0.25	256	0.0211	0.825	8250	4125
2 pole bodies	W.I.	52	157	0.0253	1.61	40	2080
Yoke	Cast steel	84	192	0.0253	1.32	12	<u>1008</u>
						Total	9653

Ampere Turns/pole = $(10/4\pi) \times 9653 / 2 = 3840$ on each pole

Equalising Connections

The air gaps at the pole faces may change with time, eg due to wear in the bearings. A Lap Wound machine has the same number of brushes as poles. All brushes of the same polarity are connected together on the stator. If the air gaps of the poles are not all the same, then some brushes will carry more current than others. This can be avoided if the commutator segments at the same voltage on the rotor are connected together.

Example

A 6 pole dynamo has a field circuit resistance of 120 ohms and there are 2000 turns/pole. For currents less than 2 amps, the flux/pole is nearly proportional to field current at 0.02 weber/amp. A constant pd of 480 volts is applied, find how long the current takes to reach 2 amps and the energy then stored in the field.

When the current is i amps, $\Phi = 0.02 i$ weber/pole

back emf due to self inductance of 6 coils

$$\begin{aligned} L \, di/dt &= 6 \times N \times d \Phi/dt \text{ volts} \\ &= 6 \times 2000 \times 0.02 \, di/dt = 240 \, di/dt \text{ volts} \end{aligned}$$

$$V = L \, di/dt + R \, i$$

Hence $480 = 240 \, di/dt + 120 \, i$

$$4 = 2 \, di/dt + i$$

$$4 e^{0.5t} = 2 e^{0.5t} \, di/dt + e^{0.5t} \, i = 2 \, d(i e^{0.5t})/dt$$

Integrate $8 e^{0.5t} = 2 (i e^{0.5t}) + \text{constant}$

$$4 = i + K e^{-0.5t}$$

$i = 0$ when $t = 0$, therefore $K = 4$

$$i = 4 \times (1 - e^{-0.5t})$$

when $i = 2$, $t = 1.38$ secs



The image shows the BI Norwegian Business School logo, which is a blue square with the letters 'BI' in white. Surrounding the logo are several colorful, 3D-style rectangular blocks representing different business programs: Business, Strategic Marketing Management, International Business, Leadership & Organisational Psychology, Shipping Management, and Financial Economics. The blocks are arranged in a fan-like pattern radiating from the center.

Empowering People. Improving Business.

BI Norwegian Business School is one of Europe's largest business schools welcoming more than 20,000 students. Our programmes provide a stimulating and multi-cultural learning environment with an international outlook ultimately providing students with professional skills to meet the increasing needs of businesses.

BI offers four different two-year, full-time Master of Science (MSc) programmes that are taught entirely in English and have been designed to provide professional skills to meet the increasing need of businesses. The MSc programmes provide a stimulating and multi-cultural learning environment to give you the best platform to launch into your career.

- MSc in Business
- MSc in Financial Economics
- MSc in Strategic Marketing Management
- MSc in Leadership and Organisational Psychology

www.bi.edu/master

BI NORWEGIAN BUSINESS SCHOOL

EFMD **EQUIS** ACCREDITED



Example

A 55 kW 4 pole shunt machine is 440 volt, 125 amp full load I_a , 600 rpm.

$E - I_f$ saturation curve, linear from origin to $E=150$ at $I_f = 0.3$

and linear from $E=400$ at $I_f = 1.5$ to $E=480$ at $I_f = 3.5$

$R_a = 0.14$ ohms Brush drop = 2 volt except at small loads when = 0

Shunt turns = 2000 turns/pole. Neglect armature reaction.

i) Find R_f to give $E = 440$ volts at no load and 600 rpm

Brush drop and $I_a R_a$ are negligible, hence from saturation curve, $I_f = 2.5$ amps

Therefore $R_f = V / I_f = 440 / 2.5 = 176$ ohms

ii) Find the output voltage as a generator on full load at $R_f = 176$ ohms.

Resistance drop in armature = $I_a R_a = 125 \times 0.14 = 17.5$ volts

Brush drop = 2 volts Total drop = 19.5 in armature circuit.

$E = V + 19.5 = 176 I_f + 19.5$

But from the saturation curve, $E = 400 + (480-400) \times (I_f - 1.5) / (3.5 - 1.5)$

$176 I_f + 19.5 = E = 400 + 40 I_f - 60$

$I_f = 320.5 / 136 = 2.36$

$V = I_f R_f = 2.36 \times 176 = 415$ volts

iii) Find R_f to generate 440 volts on full load

$E = 440 + 19.5 = 459.5$ volts

From saturation curve, $I_f = (459.5 - 340) / 40 = 2.99$ amps

$I_f R_f = 440$ volts therefore $R_f = 440 / 2.99 = 147$ ohms a reduction of 29 ohms.

iv) With $R_f = 176$ ohms, find the speed to generate $V = 440$ volts on full load.

$E = 440 + 19.5 = 459.5$ volts

$I_f = 440 / 176 = 2.5$

From the saturation curve, $I_f = 2.5$ gives $E = 440$ volts at 600 rpm

Speed to give $E = 459.5$, $N = 600 \times 459.5 / 440 = 627$ rpm

v) Find the minimum speed for self excitation at $R_f = 176$ ohms

The initial slope of the saturation curve at 600 rpm is $150 / 0.3 = 500$ ohms

Minimum speed for self excitation = $600 \times 176 / 500 = 211$ rpm

vi) A series coil is wound on each pole,

total resistance of all series coils = 0.1 ohm

Find the turns/pole for the machine to generate $V = 440$ at no load and full load.

On no load, from (i) above, $R_f = 176$ ohms.

On full load, $E = 440 + 125 \times (0.1 + 0.14) + 2 = 472$ volts

Hence from saturation curve at 600 rpm,

amp turns = $2000 \times (1.5 + 2 \times 72 / 80) = 6600$

shunt field amp turns = $2000 \times V / R_f = 2000 \times 440 / 176 = 5000$

series field amp turns = $6600 - 5000 = 1600$

series turns/pole = $1600 / I_a = 1600 / 125 = 12.8$

This must be an integer, therefore series turns/pole = 13

vii) Find series turns/pole to give 450 volts on full load, all other values as (vi)

Full load $E = 450 + 125 \times (0.1 + 0.14) + 2 = 482$ volts

amp turns = $2000 \times (1.5 + 2 \times 82/80) = 7100$

shunt amp turns = $2000 \times 450/176 = 5114$

series amp turns/pole = $7100 - 5114 = 1986$

series turns/pole = $1986/125 = 15.9$

nearest integer = 16 turns/pole

viii) The machine is run as a motor. Find the speed on 440 volts with armature load 125 amps and $R_f = 176$ ohms.

$E = 440 - 125 \times 0.14 - 2 = 420.5$ volts

$I_f = 440/176 = 2.5$ therefore $E = 440$ volts at 600 rpm

Speed = $(420.5/440) \times 600 = 573$ rpm

ix) What value of R_f is required for the machine to run as a motor on full load at 600 rpm on 440 volt supply.

$E = 420.5$ volts as (viii)

From the saturation curve, $I_f = 1.5 + (20.5/40) \times 1 = 2.01$ amps

$R_f = 440/2.01 = 219$ ohms

x) Find R_f to run as a motor on full load at 550 rpm on 440 volt supply

As before $E = 420.5$ volts

The field gives $E = 420.5$ volt at 550 rpm.

Therefore field would give $420.5 \times 600/550$ at 600 rpm = 459 volts

From saturation curve, for $E = 459$ volts, $I_f = 1.5 + 2 \times 59/80 = 2.98$

$R_f = 440/2.98 = 148$ ohms

xi) Find series turns/pole for the machine to run as a motor at 600 rpm on no load and on full load.

Assume series winding is 0.04 ohms.

On no load, $R_f = 176$ ohms as before

On full load, $E = 440 - 125 \times (0.14 + 0.04) - 2 = 415.5$ volts

From saturation curve, $I_f = 1.5 + (15.5/40) \times 1 = 1.89$ amps

Amp turns/pole = $2000 \times 1.89 = 3780$

Shunt field provides $2000 \times 440/176 = 5000$ amp turns

Series field must provide $5000 - 3780 = 1220$ amp turns

Series field carries 125 amps therefore $1220/125 = 9.8$ turns

Number of turns must be an integer, therefore 10 series turns/pole

The series field is in opposition to the shunt field

xii) Find the number of turns for the machine to run as a motor at 550 rpm on full load, otherwise as (xi).

$E = 415.5$ volts as above. This is obtained at 550 rpm

E at 600 rpm would be $415.5 \times 600/550 = 453$ volts

From saturation curve, $I_f = 1.5 + (53/80) \times 2 = 2.83$ amps

Amp turns required = $2000 \times 2.83 = 5650$

Shunt field provides 5000 amp turns as (xi)

Series field is to provide 650 amp turns with current 125 amps

Series turns = $650/125 = 5$ turns to nearest integer

These series amp turns are cumulative to the shunt amp turns.

Need help with your dissertation?

Get in-depth feedback & advice from experts in your topic area. Find out what you can do to improve the quality of your dissertation!

Get Help Now



Go to www.helpmyassignment.co.uk for more info

 **Helpmyassignment**

AC Synchronous Machines

AC Machines

AC Generators have slip rings instead of the commutator. These are solid copper or brass rings insulated from the shaft. Spring loaded carbon brushes rub against the rings to make the connection. The generator speed is determined by the supply frequency and the number of magnetic poles. A two pole machine on a 50 cycle/sec system rotates at 3000 rpm. (50 cycles/sec times 60 sec/minute). A four pole machine rotates at 1500 rpm. Brushless generators do not need slip rings. The exciter is on the same shaft and the exciter rotor supplies the ac generator field through silicon diode rectifiers.

Back emf on AC machine

Flux linking a coil on the machine is $BA \sin \theta$

The coil rotates at an angular velocity ω

$$\theta = \omega t = 2\pi f t / p$$

where p is pairs of poles

$$d\theta/dt = \omega = 2\pi f / p$$

Back emf

$$e = -N p d\Phi/dt \text{ where } N \text{ is turns / pairs of poles}$$

$$= -N p d[BA \sin(2\pi f t / p)] / dt$$

$$= -N BA 2\pi f \cos(2\pi f t / p)$$

$$\text{But } BA = \Phi_{\max}$$

$$E_{\text{rms}} = (1 / \sqrt{2}) N 2\pi f \Phi_{\max} = 4.44 N f \Phi_{\max}$$

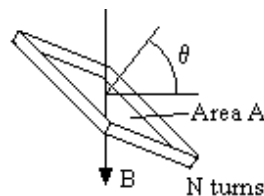

This emf equation is for a single coil rotating in a uniform magnetic field. A practical generator has windings distributed round the machine.

Large generators have the field winding on the rotor and three phase armature windings on the stator.

Three phase generation

Advantages are

Generation and transmission costs are less

Motors have a rotating field, which makes starting easy

The power and torque are constant, unlike single phase

Star/Delta transformation gives a choice of voltage

Voltage and Frequency

Most machines in the UK generate at 11 kV and in the USA at 13.8 kV. The frequency in the UK is 50 hertz and in the USA is 60 hertz.

Peripheral speed

The peripheral speed of a 34 inch diameter 2 pole rotor is nearly 300 mph.

Damping windings

Damping windings are heavy copper conductors set in the pole face and brazed at the ends to heavy copper strips to short circuit the winding. They help to reduce oscillations or sudden changes in the magnetic flux. They play an essential part in the event of a fault on the system connected to the generator.

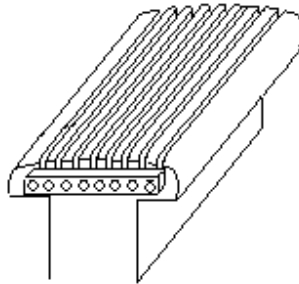
Hydrogen cooling

Hydrogen cooling reduces the windage loss by 90%, eg from 400 kW to 40 kW and the rating could be increased by 20%. First used in the USA in 1930 where the 60 hz system means higher windage loss than a 50 hz system. Used in the UK in the 1950s but the additional cost was enormous. The machine had to be in an explosion proof gas tight enclosure with complicated seals on the shaft. Further costs included expensive gas detection alarms, oil contamination, CO₂ fire protection etc.

Electrical and physical angles

The angle between adjacent pole centres is 180° electrical degrees whereas the physical angle is 180° / (number of pairs of poles).

Span of coils

The span of the coils may be less than 180° electrical degrees.

Let the coil span be 2λ electrical radians

This reduces the emf by a factor k_p

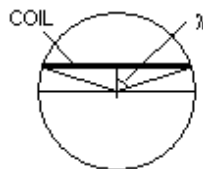

Where $k_p = \frac{\int \text{Sin}\theta \, d\theta \text{ from } \pi/2-\lambda \text{ to } \pi/2+\lambda}{\int \text{Sin}\theta \, d\theta \text{ from } \pi/2-\pi/2 \text{ to } \pi/2+\pi/2}$

hence $k_p = \frac{[-\text{Cos}\theta] \text{ from } \pi/2-\lambda \text{ to } \pi/2+\lambda}{[-\text{Cos}\theta] \text{ from } 0 \text{ to } \pi}$

$$k_p = \frac{-[\text{Cos}(\pi/2+\lambda) - \text{Cos}(\pi/2-\lambda)]}{-[\text{Cos}(\pi) - \text{Cos}(0)]}$$

$$k_p = (2 \text{Sin } \lambda) / 2 = \text{Sin } \lambda$$

$E_{\text{rms}} = 4.44 k_p N f \Phi_{\text{total}}$ where $k_p = \text{Sin } \lambda$ is the pitch factor

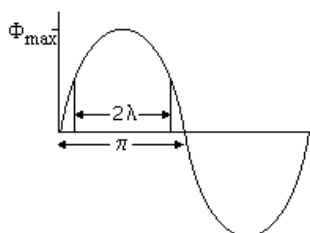

The reduction in coil pitch causes a much larger reduction in the harmonic content. The pitch factor for the n th harmonic is $\text{Sin}[\pi/2 - n(\pi/2 - \lambda)]$.

For n th harmonic where $n = 2m + 1$, pitch factor $k_{np} = (-1)^m \text{Sin}(n \lambda)$

Thus for the 3rd harmonic the pitch factor $k_{3p} = -\text{Sin}(3 \lambda)$

5th harmonic $k_{5p} = \text{Sin}(5 \lambda)$

7th harmonic $k_{7p} = -\text{Sin}(7 \lambda)$

Example

6 slots / pole pitch and 5 slots / coil pitch

$$2\lambda = (5/6) \pi$$

Pitch Factor $k_p = \text{Sin } \lambda = \text{Sin}(75^\circ) = 0.966$

Hence the smaller coils cause a reduction in emf of only 3.4%

$\lambda = 75^\circ$ thus the pitch factor for the 3rd harmonic is $-\text{Sin}(225^\circ) = 0.707$

and for the 5th harmonic the pitch factor is 0.259.

Factor due to phase difference in conductor emfs

With the conductors evenly distributed round the machine, the voltages induced in each conductor are not in phase. The conductors of a single phase machine generate voltages whose vectors follow the circumference of a circle. The vector sum is proportional to D while the scalar sum is proportional to $\pi D/2$. Thus the voltage generated with a large number of conductors is $D/(\pi D/2)$ of the possible maximum, ie 64%.

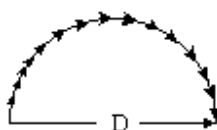

If the conductors are divided into three phases, the vector sum for one coil is $D/2$ and the maximum possible is $\pi D/6$.

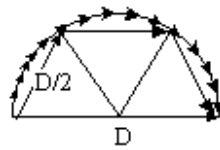

The generated voltage is $3/\pi = 95\%$ of the maximum.

The windings of the three phases are spaced 120 electrical degrees apart.

The diagram shows a typical winding with two conductors in each slot and the coil pitch one slot less than π .

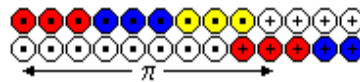

The completed winding for a 2 pole machine would be like this.

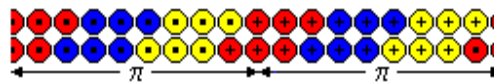

Brain power



By 2020, wind could provide one-tenth of our planet's electricity needs. Already today, SKF's innovative know-how is crucial to running a large proportion of the world's wind turbines.

Up to 25 % of the generating costs relate to maintenance. These can be reduced dramatically thanks to our systems for on-line condition monitoring and automatic lubrication. We help make it more economical to create cleaner, cheaper energy out of thin air.

By sharing our experience, expertise, and creativity, industries can boost performance beyond expectations. Therefore we need the best employees who can meet this challenge!

The Power of Knowledge Engineering

Plug into The Power of Knowledge Engineering.
Visit us at www.skf.com/knowledge





In this example, the coil pitch is $(8/9)\pi$
Hence the pitch factor $k_p = \sin(80^\circ) = 0.985$

But the voltages in each conductor are not in phase. It can be seen that the voltage in each of the three conductors is $2r \sin(10^\circ)$ where r is their vector sum.

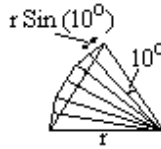

The distribution factor $k_d = (\text{vector sum}) / (\text{scalar sum})$

$$k_d = 2 \sin(\theta/2) / [2c \sin\{\theta/(2c)\}]$$

where $\theta^\circ = \pi/\text{number of phases}$ and $c = \text{slots/phase/pole}$

If the number of phases = 3, then $2 \sin(\theta/2) = 1$

and $k_d = 1 / [2c \sin\{\pi/(6c)\}^\circ]$ or $k_d = 1 / [2c \sin(30^\circ/c)]$

If $c = 1$, $k_d = 1$

If c is very large $k_d = 1 / [2c \pi/(6c)] = 3/\pi = 0.955$

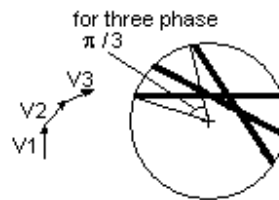

In this example, phases = 3 and $c = 3$

$$k_d = 1 / [6 \sin(10^\circ)] = 0.960$$

Total factor = $k_p k_d = 0.985 \times 0.960 = 0.946$

For the n^{th} harmonic

$$k_{np} = \sin(n\lambda)$$

$$k_{nd} = \sin(n\theta/2) / [c \sin\{n\theta/2c\}]$$

For the 5th harmonic

$$k_{5p} = \sin(400^\circ) = 0.642$$

$$k_{5d} = \sin(150^\circ) / [3 \sin\{300^\circ/6\}] = 0.5 / (3 \sin 50^\circ) = 0.218$$

Total factor = $k_{5p} k_{5d} = 0.642 \times 0.218 = 0.140$

The factor for the 5th harmonic is only 15% of the fundamental factor.

In the example, suppose there are 30 turns per phase, ie 10 conductors in each layer in each slot

The generated emf would be

$$\begin{aligned} E_{\text{rms}} &= 4.44 \times 0.946 \times 30 \times f \times \Phi_{\text{total}} \\ &= 6300 \Phi_{\text{total}} \text{ at 50 hertz} \end{aligned}$$

If the maximum flux density is 1.2 tesla and the generated emf is 240 volts per phase, the area of the pole face is 317 cm².

Fractional Slots per pole per phase

In the above example. There were 3 slots per pole per phase.

It is possible to have fractional slots per pole per phase.

The following arrangement has 3 ½ slots per pole per phase.

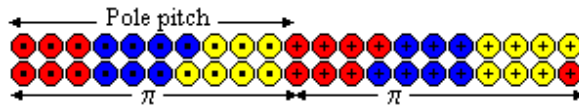

Fractional slots have a number of advantages.

- The same laminations can be used for a different number of poles
- There is greater flexibility in the make up of the winding
- Certain harmonics are killed

Example

An 8 pole generator has a flux density in the air gap

1/12 th pole pitch	0	1	2	3	4	5	6	7
B tesla	0	0.06	0.5	0.76	0.83	0.85	0.86	0.85

Armature dia 100 cms, conductor length 25 cms speed 750 rpm

Speed of conductor $750 \times \pi \times 1 / 60 = 39.3$ m/sec

Area swept by conductor = $0.25 \times 39.3 = 9.825$ m² / sec

emf = B x 9.825 volts

1/12 th pole pitch	0	1	2	3	4	5	6	7
B tesla	0	0.06	0.5	0.76	0.83	0.85	0.86	
emf	0	0.59	4.91	7.47	8.15	8.35	8.45	
emf ²	0	0.35	24.1	55.8	66.4	69.7	71.4	

emf_{rms} per conductor = $\sqrt{[\Sigma(0.35 \text{ to } 69.7) + 71.4/2]/6} = 6.45$ volts

Example

8 pole machine, 3 phase, star winding, 2 layer, 90 slots, coil pitch 1 – 10

Phase A	Phase band no	1	4	7	10	13	16	19	22
	Number of coil side	4	3	4	4	4	3	4	4
Phase B	Phase band no	3	6	9	12	15	18	21	24
	Number of coil side	4	4	4	3	4	4	4	3
Phase C	Phase band no	5	8	11	14	17	20	23	2
	Number of coil side	4	3	4	4	4	3	4	4

Show the emfs are balanced and contain no 3rd or 5th harmonics

Calculate the factors for the fundamental and 7th harmonic

Slots / pole = $90/8 = 45/4$

Winding diag repeats itself after 4 poles and is symmetrical if there are a multiple of 4 poles. There are 8 poles so the winding is symmetrical.

$\lambda = (9 / 11\frac{1}{4}) \times 180^\circ / 2 = 72^\circ$

$c = 15$ and $\theta = 60^\circ$

Fundamental

$k_p = \text{Sin} (\lambda) = 0.951$

$k_d = \text{Sin} (\theta/2) / [c \text{Sin} \{ \theta / (2c) \}] = 0.955$

Total factor for the fundamental = $k_p k_d = 0.91$

"I studied English for 16 years but...
...I finally learned to speak it in just six lessons"

Jane, Chinese architect

ENGLISH OUT THERE

Click to hear me talking before and after my unique course download



3rd harmonics are in phase in each winding and cancel out in the line voltage and in the secondaries of delta star transformers.

5th harmonic pitch factor = $\sin(5\lambda)$

$$\sin(5\lambda) = \sin(360^\circ) = 0 \text{ Hence } 5^{\text{th}} \text{ harmonic is zero}$$

7th harmonic pitch factor = $-\sin(504^\circ) = -\sin(144^\circ) = -0.588$

$$k_{7d} = \sin(7 \times \theta/2) / [c \sin\{7 \times \theta / (2c)\}]$$

$$= \sin(210^\circ) / [15 \sin(14^\circ)] = 0.138$$

Total factor for the 7th harmonic = $k_{7p} k_{7d} = 0.081$

In fact there is a further reduction as the 7th harmonic is not generated at the same level as the fundamental before this factor is applied, the fundamental is generated by the main flux whereas the harmonics are only generated by irregularities in the flux.

Effect of harmonics on the rms value of the generated voltage

Let $E = E_1 \cos(\phi_1 + \omega t) + E_3 \cos(\phi_3 + 3\omega t) + E_5 \cos(\phi_5 + 5\omega t) + \dots$

$$E^2 = E_1^2 \cos^2(\phi_1 + \omega t) + E_3^2 \cos^2(\phi_3 + 3\omega t) + E_5^2 \cos^2(\phi_5 + 5\omega t) + \dots$$

$$+ E_1 E_3 \cos(\phi_1 + \omega t) \cos(\phi_3 + 3\omega t) + \dots$$

$$\text{Average value of } E_q^2 \cos^2(\phi_q + q\omega t) = E_q^2/2$$

$$\text{Average value of } E_q E_r \cos(\phi_q + q\omega t) \cos(\phi_r + r\omega t) = 0$$

$$\text{Hence } E^2 = \frac{1}{2} [E_1^2 + E_3^2 + E_5^2 + E_7^2 + \dots]$$

$$\text{Hence } E_{\text{rms}} = 1/\sqrt{2} [\sqrt{\{E_1^2 + E_3^2 + E_5^2 + E_7^2 + \dots\}}]$$

$$= E_1/\sqrt{2} [\sqrt{\{1 + (E_3^2/E_1^2) + (E_5^2/E_1^2) + (E_7^2/E_1^2) + \dots\}}]$$

Suppose 3rd harmonic = 15%, 5th = 7% and 7th = 5% of fundamental

$$E_{\text{rms}} = E_1/\sqrt{2} [\sqrt{(1 + 0.0225 + 0.0049 + 0.0025)}] = 1.015 E_1/\sqrt{2}$$

Harmonics are reduced by winding factors and have little effect on E_{rms}

The effect of slot ripple on the generated voltage.

Suppose the slots exactly line up with the pole face. When the rotor moves $\frac{1}{2}$ slot width, the flux is altered because one tooth is replaced by one air gap.

The flux pulsates with one complete cycle for every time a slot passes.

The fundamental frequency is $f = (\text{rps}) \times p$ where p is the pairs of poles.

There are c slots/phase/pole

Therefore in one revolution, $c \times (3 \text{ phases}) \times 2p$ slots pass any one point

The flux pulsates at a frequency of $6 c p \times (\text{rps}) = 6c f$

$$\Phi = \Phi_0 [1 + A \sin(6c 2\pi f t)]$$

$$e = E_{\text{max}} [1 + A \sin(6c 2\pi f t)] \sin(2\pi f t)$$

$$e = E_{\text{max}} \sin(2\pi f t) + \frac{1}{2} E_{\text{max}} A [\cos(6c-1)2\pi f t] - \frac{1}{2} E_{\text{max}} A [\cos(6c+1)2\pi f t]$$

Slot ripple causes harmonics of a high order that interferes with communication equipment. There is no easy way to eliminate these harmonics, but they can be reduced by;

- Using fractional slot windings
- Axial skewing of slots (on the stator or rotor) by one pole pitch.
- Axial skewing of poles
- Rounding off corners of pole shoes
- Use of better ratio of tooth width to slot width
- Offsetting of damper bars

EMF with the winding in slots

In actual machines there are two sets of coils for each phase. Each set for each phase of a three phase machine covers $\pi/3$ of the circumference. The diagram shows a typical arrangement with three slots for each phase. Each slot contains the lower half of one coil and the upper half of another, ie half of each coil is in the lower part of one group of slots and half in the upper part of another group of slots. The diagram shows one coil in full with a coil span of 2λ .

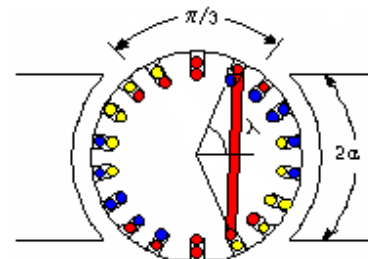

Let E_1 be the emf in the upper conductors of one set of coils. The emf in the lower conductors of the same coils is the same shaped wave but at an angle of $(\pi - 2\lambda)$ later. It is shown as E_2 . The total emf in one set of coils is $E_1 + E_2$. The emf in the other set of coils is the same $E_1 + E_2$.

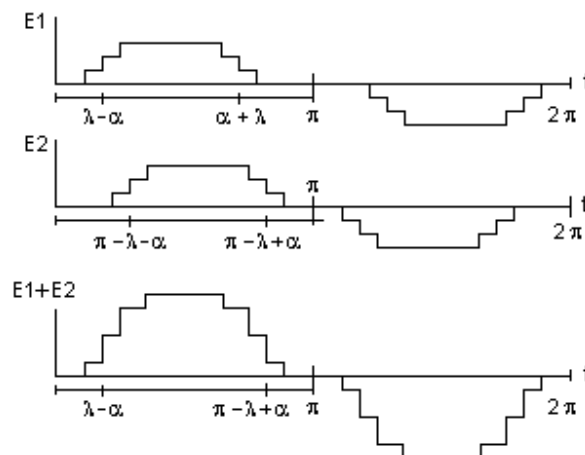

The $E_1 + E_2$ voltage curve for a half cycle is symmetrical about $\pi/2$. With a large number of slots, the steps become blurred into slopes.

Generated harmonics.

The shape of the generated emf E can be plotted out and then analysed by Fourier Analysis.

This can easily be done by computer.

Let the generated emf be represented by

$$E = A_1 \cos(2\pi ft) + A_3 \cos(6\pi ft) + A_5 \cos(10\pi ft) + A_7 \cos(14\pi ft) + \dots + B_1 \sin(2\pi ft) + B_3 \sin(6\pi ft) + B_5 \sin(10\pi ft) + B_7 \sin(14\pi ft) + \dots$$

The value of the n th harmonic is;

$$A_n = (1/\pi) \int E \cos(n x) dx \text{ from } 0 \text{ to } 2\pi \quad (\text{all zero with a symmetrical wave form}).$$

$$B_n = (1/\pi) \int E \sin(n x) dx \text{ from } 0 \text{ to } 2\pi$$

With x in degrees, the value of the n th harmonic is;

$$A_n = (1/180) \int E \cos\{n x(3.14159/180)\} dx \text{ from } 0 \text{ to } 360$$

$$B_n = (1/180) \int E \sin\{n x(3.14159/180)\} dx \text{ from } 0 \text{ to } 360$$

Example

Pole angle $\alpha = 60^\circ$, coil pitch angle $\lambda = 80^\circ$, large number of slots.
 Find the relative values of the fundamental and the harmonics

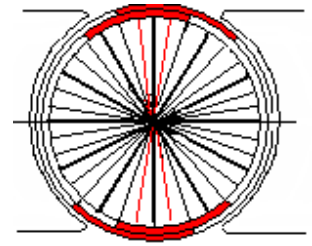

Consider one phase. At any angle of the rotor, the emf is proportional to the number of conductors under a pole face. This is proportional to the total angle of conductors under the pole face.

In the position shown, the emf is zero as the conductors under each pole are two halves of the same coil. Plot the total angle of conductors under a pole face as the rotor is rotated clockwise in steps of 10°

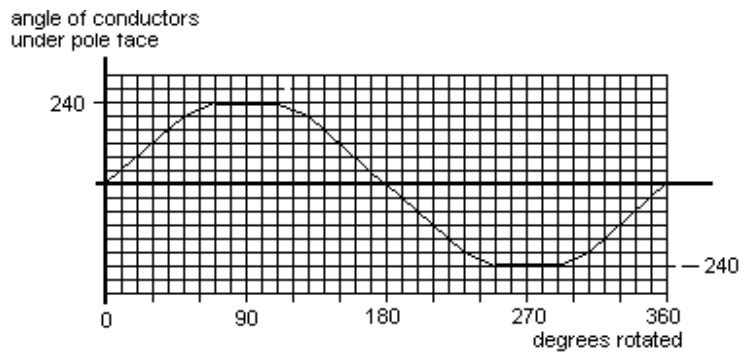

What do you want to do?

No matter what you want out of your future career, an employer with a broad range of operations in a load of countries will always be the ticket. Working within the Volvo Group means more than 100,000 friends and colleagues in more than 185 countries all over the world. We offer graduates great career opportunities – check out the Career section at our web site www.volvogroup.com. We look forward to getting to know you!

VOLVO
 AB Volvo (publ)
www.volvogroup.com

VOLVO TRUCKS | RENAULT TRUCKS | MACK TRUCKS | VOLVO BUSES | VOLVO CONSTRUCTION EQUIPMENT | VOLVO PENTA | VOLVO AERO | VOLVO IT
 VOLVO FINANCIAL SERVICES | VOLVO 3P | VOLVO POWERTRAIN | VOLVO PARTS | VOLVO TECHNOLOGY | VOLVO LOGISTICS | BUSINESS AREA ASIA



The qBASIC program, which uses steps of 1/10 degree for x , evaluates the fundamental and first 15 harmonics (even harmonics are zero);

```
CLS
FOR q = 1 TO 15 STEP 2
Eq# = 0
FOR x = 1 TO 3600
I# = 0
IF x <= 500 THEN E# = .4 * x
IF x > 500 AND x <= 700 THEN E# = 200 + (x - 500) * .2
IF x > 700 AND x <= 1100 THEN E# = 240
IF x > 1100 AND x <= 1300 THEN E# = 240 - (x - 1100) * .2
IF x > 1300 AND x <= 2300 THEN E# = 200 - (x - 1300) * .4
IF x > 2300 AND x <= 2500 THEN E# = -200 - (x - 2300) * .2
IF x > 2500 AND x <= 2900 THEN E# = -240
IF x > 2900 AND x <= 3100 THEN E# = -240 + (x - 2900) * .2
IF x > 3100 AND x <= 3600 THEN E# = -200 + (x - 3100) * .4
I# = E# * SIN(q * x * 3.14159 / 1800)
Eq# = Eq# + I#
NEXT x
Eq# = Eq# / (240 * 1800)
PRINT "E"; q; " = "; Eq#
NEXT q
```

The results rounded to 0.001 are;

Harmonic	Fundamental	3 rd	5 th	7 th	9 th	11 th	13 th	15 th
Magnitude	1.037	0	-0.027	0.007	0	0.003	-0.004	0

Capacitive loading

For resistive or inductive loading, harmonics content is usually small.

However for capacitive loading (eg a long high voltage line with no load), the harmonics will be magnified and can be troublesome.

Equivalent Circuit for a synchronous machine

The emf and output voltage are related by the vector equation

$$e = v + i \cdot R + j(i \cdot X)$$

X is the leakage reactance and R is the resistance. In a practical machine, R is negligible compared to X .

The effect of R can be ignored in the impedance but R is required for calculations of copper loss.

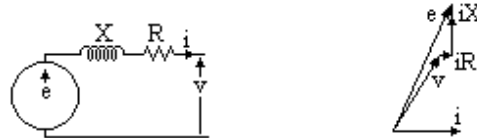

Leakage reactance and Armature reaction

The effect of mmf due to armature currents in producing flux linking with the main flux is called the armature reaction.

The effect of mmf due to armature currents in producing flux linking with the armature windings only is called the leakage reactance effect.

Leakage Reactance

Leakage reactance is due to flux paths round the conductors in the slots, at the ends of the conductors outside the core and zigzag flux between the armature windings and the pole face.

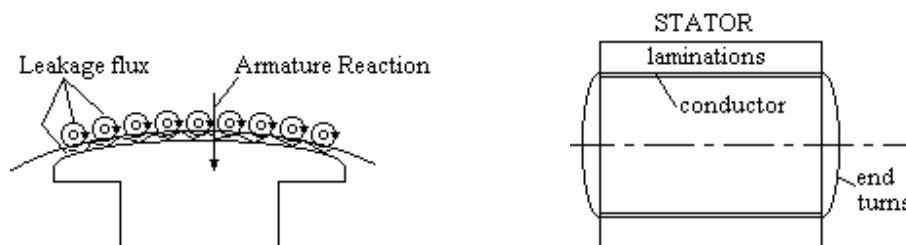

All the effects of leakage flux are summed up by $X_{Leakage}$ and can be determined from the dimensions of the machine. In most machines the value is about right, but in turbo-alternators it must be increased, eg by not filling the slots with winding so the slot leakage is increased.

On short circuit, the initial current is E / X_d'' where E is the emf and X_d'' is the subtransient reactance. The leakage reactance is the main limiting factor in the initial value of the short circuit current. Thus X_d'' is usually taken as the leakage reactance.

Percentage Reactance

$$X_d'' = (\text{Reactance in ohms}) \times I_{ph} \times 100 \% / V_{ph}$$

Armature Reaction

The armature reaction has a big effect on the magnetising force. The unity power factor component distorts the field which has the effect of rotating the field and slightly reducing its magnitude. The zero power factor inductive component directly opposes the exciter magnetising force and greatly reduces the magnitude of the field.

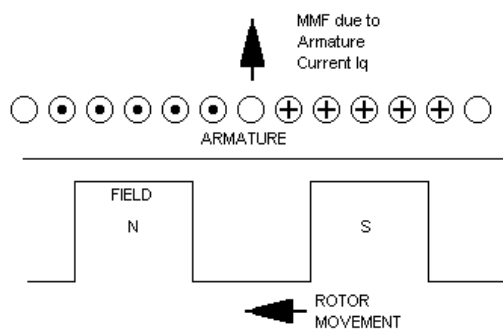

This effect is quantified as the synchronous reactance. It is measured by the open circuit and short circuit tests.

However the mmf due the wattles component of the current is centred on the pole axis. Zero power factor lagging currents are directly demagnetizing while zero power factor leading currents boost the field.

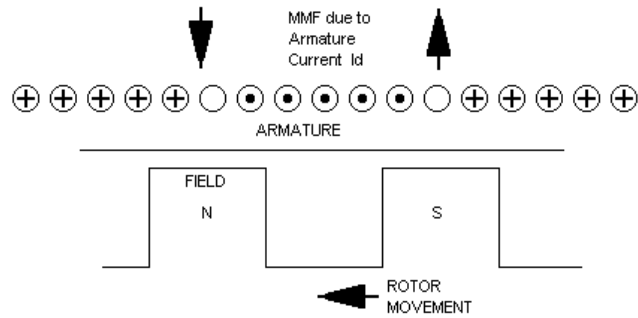

The armature reaction due to the unity power factor component rotates the axis of the field while the zero power factor component alters its value.

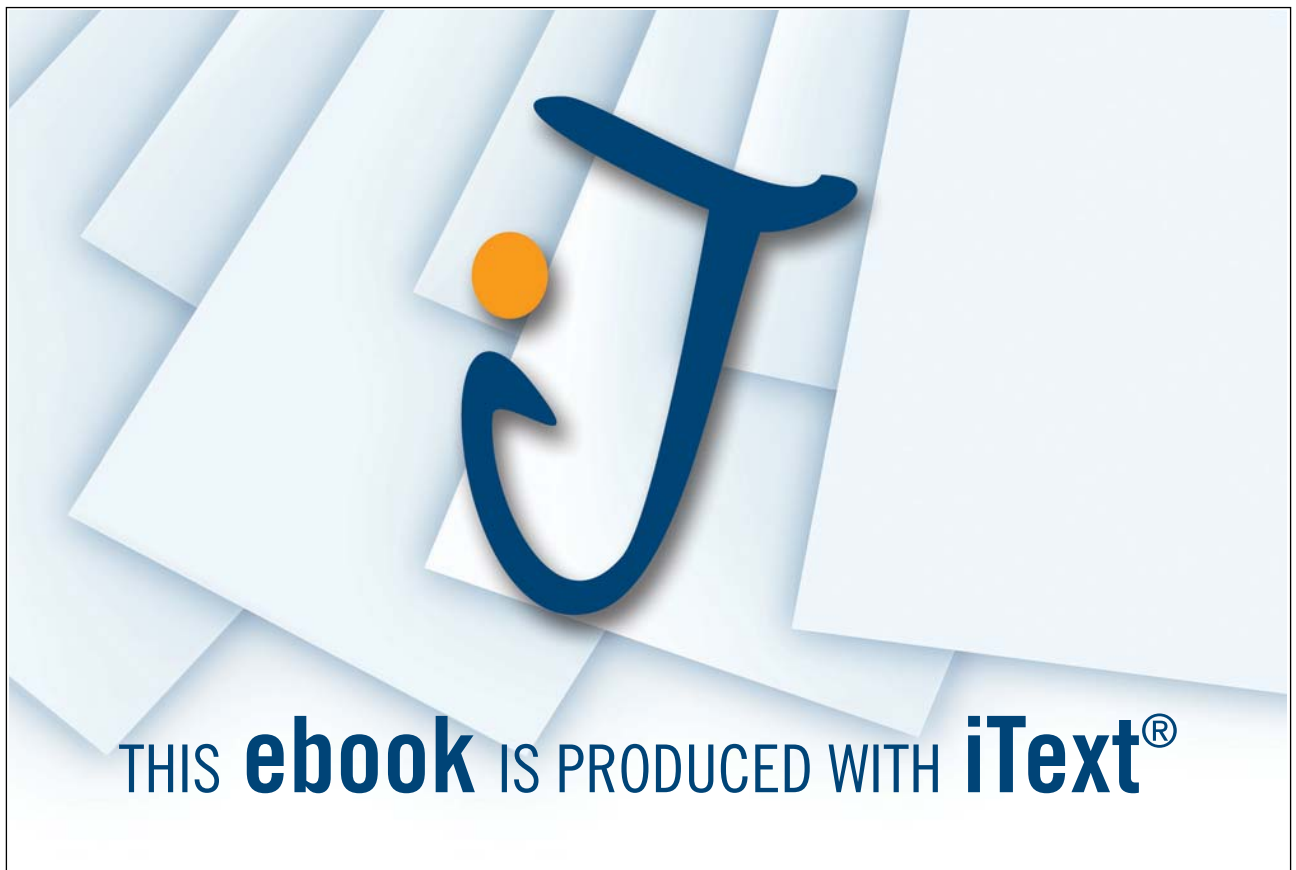

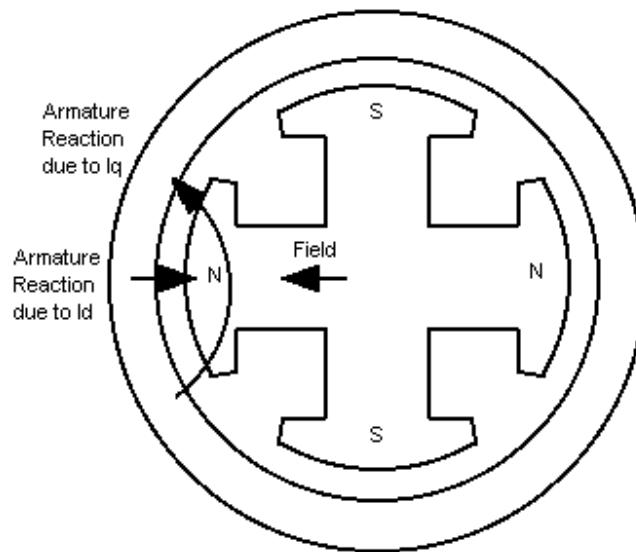

Open Circuit Test

With the generator disconnected and running at rated speed, the field current is slowly raised. The generator voltage is plotted against the field current. The result is a curve following the magnetisation curve of the iron.

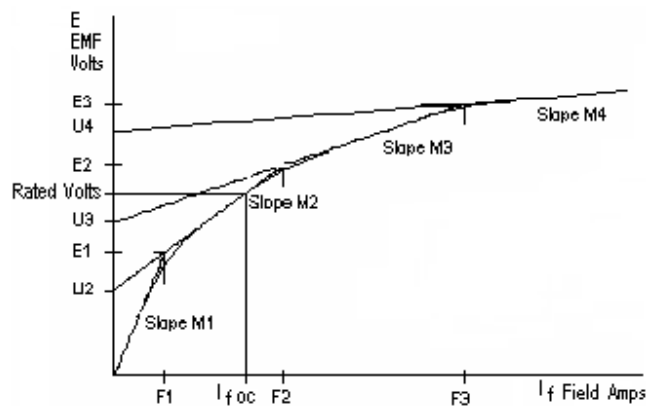

It can be represented approximately by four straight lines, slopes M₁, M₂, M₃ and M₄ with intercepts U₂, U₃ and U₄ which meet at points (F₁,E₁), (F₂,E₂) and (F₃,E₃).

Short Circuit Test

For the short circuit test, the generator terminals are connected together on short circuit. The generator is run up to rated speed and the field current slowly raised. The field current is plotted against generator output current. The result is a straight line.

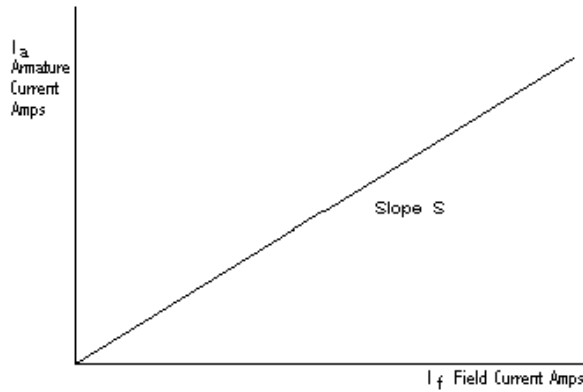

The reason that the short circuit curve is a straight line is because the leakage reactance is very much greater than the resistance. Therefore the output current lags the emf by 90 degrees and the ampere turns of the output current directly oppose the field ampere turns. The field ampere turns therefore equal the ampere turns of the output current plus the ampere turns to provide the emf. As the emf is small, the excitation is near the origin where the relation between field and emf is linear.

Vector diagram for the short circuit test

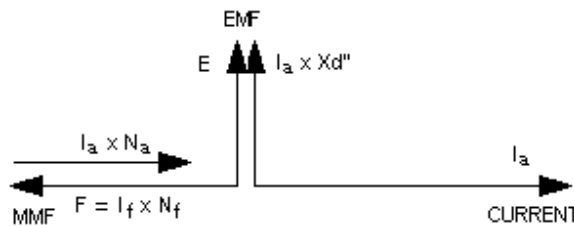

The emf E is produced by the ampere turns due to the field current minus the ampere turns due to armature reaction. This drives the armature current I_a against the leakage reactance X_d'' .

Hence $E = M_1 (I_f - I_a N_a / N_f)$ and $E = I_a X_d''$

Thus $I_a (X_d'' + M_1 \cdot N_a / N_f) = M_1 I_f$

But $I_a = S I_f$

Therefore $(X_d'' + M_1 \cdot N_a / N_f) = M_1 / S$

Synchronous Reactance X_d

The Synchronous Reactance X_d is defined as the ratio of the slope of the open circuit characteristic near the origin to the slope of the short circuit characteristic. This ratio has the dimensions of emf / current so is called reactance.

Thus $X_d = M_1 / S$

Therefore $N_a / N_f = (X_d - X_d'') / M_1$

Machine Reactances on the Direct and Quadrature axes

On the Direct Axis;

$$\begin{aligned} E_d &= U + M \cdot (\text{Net ampere turns on direct axis}) / N_f \\ &= U + M \cdot (I_f \cdot N_f - I_d \cdot N_a) / N_f \\ &= U + M \cdot (I_f - I_d \cdot (X_d - X_d'') / M_1) \end{aligned}$$

Where U and M have the appropriate values for the emf

On the Quadrature Axis (the axis between the poles) the air gap is larger and the magnetism is approximately proportional to the mmf.

Let X_q'' be the leakage reactance to the quadrature component of the load current and X_q be the quadrature synchronous reactance.

As on the direct axis but without saturation and no mmf supplied by the exciter,

$$E_q = I_q \times (X_q - X_q'')$$

Reactance curve over pole pitch

$$\begin{aligned} X_{ad} / X_{aq} &= [(4/\pi) \int B_{\max} \sin^2 \cdot dx] / [(4/\pi) \int B_{\max} \cos^2 x dx] \\ &\text{both integrals from } \pi/2 - \theta \text{ to } \pi/2 \end{aligned}$$

$$= [\theta + \frac{1}{2} \sin(2\theta)] / [\theta - \frac{1}{2} \sin(2\theta)]$$



www.sylvania.com

We do not reinvent
the wheel we reinvent
light.

Fascinating lighting offers an infinite spectrum of possibilities: Innovative technologies and new markets provide both opportunities and challenges. An environment in which your expertise is in high demand. Enjoy the supportive working atmosphere within our global group and benefit from international career paths. Implement sustainable ideas in close cooperation with other specialists and contribute to influencing our future. Come and join us in reinventing light every day.

Light is OSRAM

OSRAM
SYLVANIA

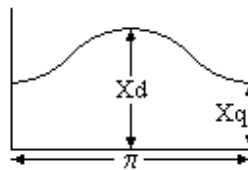

If $\theta = 60^\circ$ then $X_{ad}/X_{aq} = 2.4$

Experience shows that this figure is not correct due to fringing flux which cannot be analysed. A better result is obtained by comparing areas.

X_{ad} is proportional to $2 \int \sin x \, dx$ from $\pi/2 - \theta$ to $\pi/2 = \sin \theta$

X_{aq} is proportional to $2 \int \cos x \, dx$ from $\pi/2 - \theta$ to $\pi/2 = 1 - \cos \theta$

$X_{ad} / X_{aq} = [\sin \theta] / [1 - \cos \theta] = 1 / \tan (\theta/2)$

If $\theta = 60^\circ$ then $X_{ad}/X_{aq} = 1.73$ which is a reasonable figure.

Example

3 phase 4 pole (non salient) 50 Hz alternator with 42 slots, conductors in 2 layers. Consecutive phase bands in same layer with 4 and 3 slots alternatively. Each phase 28 turns in series. Pitch 10 slots. Rotor dia 60cms, length 100cms, air gap 1cm. Estimated slots and iron reluctance reduce flux wave by 40% of value as calculated for no slots and infinite permeability. Leakage reactance per phase is 10% of synchronous reactance.

Show phases are balanced and calculate the synchronous reactance.

There are 14 slots/phase so there are 2 conductors in each layer in each slot and 56 conductors in series in each phase to give 28 turns in series

$$c = \text{slots/phase/pole} = 42 / (3 \text{ phase} \cdot 4 \text{ poles}) = 3.5$$

$$k_{d1} = 1 / \{2 \cdot 3.5 \cdot \sin(30/3.5)\} = 0.9585$$

coil pitch is 10 whereas span between poles is 10.5

$$k_{p1} = \sin(90 \cdot 10 / 10.5) = 0.9972$$

$$k_{w1} = 0.958 \cdot 0.9972 = 0.956$$

X = rms volts in one phase due to rms amps in that phase

$$F = \text{mmf} = (4/\pi) (3/2) F_m k_{w1} \sin(\theta - \omega t)$$

where F_m is max mmf due to one phase

56 conductors in series = 28 turns spread over 2 pairs of poles

hence $F_m = 14\sqrt{2} I_{rms}$ ampere turns/pair of poles]

Hence F due to 3 phases is given by

$$F = (4/\pi) (3/2) 14\sqrt{2} I_{rms} k_{w1} \sin(\theta - \omega t)$$

$$= 36.1 I_{rms} \sin(\theta - \omega t) \text{ ampere turns}$$

Magnetizing Force $H = 1.26 \cdot F/2$ oersted

Hence $B = 60\% 1.26 \cdot F / (2 \cdot 10^{-2}) \cdot 10^{-6}$ tesla

$$= 0.00136 I_{rms} \sin(\theta - \omega t) \text{ tesla}$$

$$B_{max} = 0.00136 I_{rms}$$

Max emf = $B_{max} l v \cdot k_{w1} \cdot \text{conductors in series}$

Where B in tesla, l in metres and v in metres/sec
 Max emf = $0.00136 I_{rms} \cdot 1 \cdot \pi \cdot 0.6 \cdot rps \cdot 0.956 \cdot 56$ where rps = 25
 hence max emf = $3.42 I_{rms}$
 rms value of emf = $3.42/(\sqrt{2}) = 2.42$ volts / amps rms
 $X_A = 2.42$ ohms
 $X_L / X_A = 1/10$
 $(X_S - X_A) / X_a = 1/10$
 $10 X_S - 24.2 = X_S$
 $X_S = 2.69$ ohms

Vector Diagram on load

The suffix L will be used to signify the steady state on load condition.

Let the generator be connected to an external load of resistance R_L and inductive reactance X_L and let the component of the armature current be I_{dL} on the direct axis and I_{qL} on the quadrature axis.

The vector diagram of emfs and currents can be drawn.

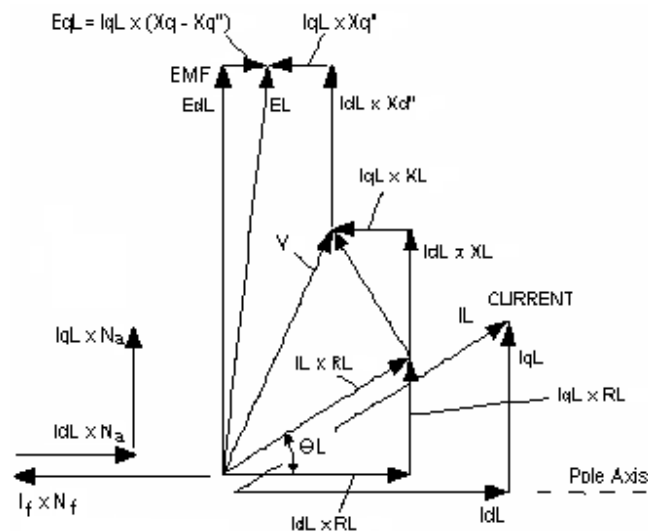

$$\tan \theta_L = I_{qL} \cdot R_L / (I_{qL} \cdot (X_q - X_{q''}) + I_{qL} \cdot X_{q''} + I_{qL} \cdot X_L)$$

$$= R_L / (X_q + X_L)$$

$V =$ Normal Busbar Volts

$$I_L = V / \sqrt{(R_L^2 + X_L^2)}$$

$$I_{dL} = I_L \cos \theta_L$$

$$I_{qL} = I_L \sin \theta_L$$

Hence the vector diagram can be drawn

Draw vectors $I_L \cdot R_L, I_{dL} \cdot X_L, I_{qL} \cdot X_L$ to get vector V

Draw vectors $I_{dL} \cdot X_{d'}$ and $I_{qL} \cdot X_{q''}$ to get E_L

Alternatively;

$$E_L = \sqrt{[(I_{qL} \cdot R_L + I_{dL} \cdot X_L + I_{dL} \cdot X_{d'})^2 + (I_{qL} \cdot X_q - I_{qL} \cdot X_{q''})^2]}$$

EL is the emf generated by the machine. It is rotated from the direct axis by the armature reaction on the quadrature axis which is shown on the diagram as EqL

$$EL = U + M \cdot [I_f \cdot N_f - I_d L \cdot N_a] / N_f$$

$$\text{and } N_a / N_f = (X_d - X_d'') / M_1$$

$$\text{Therefore } EL = U + M \cdot [I_f - I_d L \cdot (X_d - X_d'') / M_1]$$

Hence I_f can be evaluated

$$I_f = (EL - U) / M + I_d L \cdot (X_d - X_d'') / M_1$$

Where U and M have values applicable to the emf EL

Parallel operation of AC generators

Suppose two AC generators are switched into parallel operation and No 2 generator slows behind No 1. The voltages are no longer in phase and a current I will circulate driven by the vector voltage $V_1 - V_2$. The circuit is highly inductive so the current lags this voltage by almost 90° .

It can be seen that $V_1 \bullet I$ is positive and $V_2 \bullet (-I)$ is negative.

Therefore load on Generator No 1 increases and it slows down. The load on Generator No 2 is reduced and it speeds up bringing the generators back into synchronism.



CHALLENGING PERSPECTIVES

Internship opportunities

EADS unites a leading aircraft manufacturer, the world's largest helicopter supplier, a global leader in space programmes and a worldwide leader in global security solutions and systems to form Europe's largest defence and aerospace group. More than 140,000 people work at Airbus, Astrium, Cassidian and Eurocopter, in 90 locations globally, to deliver some of the industry's most exciting projects.

An **EADS internship** offers the chance to use your theoretical knowledge and apply it first-hand to real situations and assignments during your studies. Given a high level of responsibility, plenty of learning and development opportunities, and all the support you need, you will tackle interesting challenges on state-of-the-art products.

We welcome more than 5,000 interns every year across disciplines ranging from engineering, IT, procurement and finance, to strategy, customer support, marketing and sales. Positions are available in France, Germany, Spain and the UK.

To find out more and apply, visit www.jobs.eads.com. You can also find out more on our **EADS Careers Facebook page**.

AIRBUS **ASTRIUM** **CASSIDIAN** **EUROCOPTER**

EADS



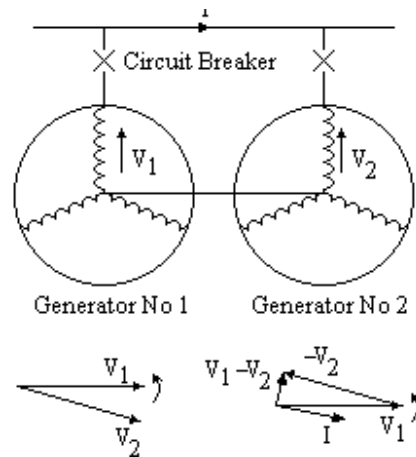

Thus AC generators will operate in parallel in synchronism. As they are in synchronism, they must run at the same speed.

The governor of the engine driving the generator controls the power output as a function of the speed. Therefore when two AC generators are running in synchronism, the power sharing of sets is controlled by the governor set points.

Altering the voltage on either of the sets has no effect on the power sharing.

For satisfactory power sharing, the governors must have a droop so that as the set is loaded up, the speed falls. Typically the change in speed between no load and full load is about 5%. The governor has a manual control that adjusts the set point, ie the position of the speed control relative to the synchronous speed.

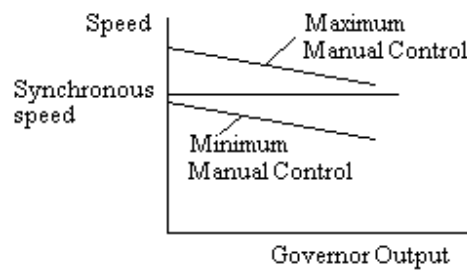

For unattended operation the manual control is replaced by a slow acting automatic control eg by a DC motor driving through a slow acting worm gear drive. Speed control is through the fast acting governor but the slow acting control in effect moves the governor set point. An even longer term control is also required so that any electric clocks on the system continue to read the correct time. When the clocks read fast or slow, the speed is reduced or increased a fraction respectively. A manned power station would have an electric and a crystal clock side by side on the control panel.

Synchronising an AC generator

Before switching an AC generator into parallel operation;

- i) The voltages must be the same
- ii) The speeds must be the same
- iii) The peak value of the voltages must occur at the same instant

This is achieved by adjusting the field resistance so that the voltages are the same and connecting a synchroscope. One coil of the synchroscope is connected to the “running volts” and the other to the “incoming volts”. The synchroscope rotates as the voltages come into and out of synchronism, the speed of rotation depending on the difference in speeds. The speed of the incoming set is adjusted till the synchroscope is rotating slowly in the clockwise direction and the circuit breaker is closed at the instant when the synchroscope needle is in the 12 o’clock position. The sets are now locked in synchronism. The governor of the incoming set is immediately manually raised to load up the incoming set.

Voltage Control of AC generators by the AVR

An AVR, (the Automatic Voltage Regulator), is required to keep the output voltage constant. A lagging current heavily reduces the field mmf while a leading current increases the field mmf. Hence an automatic voltage regulator controlling the field current is required to keep the output voltage constant.

If two machines are locked in synchronism, the power output of each depends on the governor setting (ie the set point of the governor). Any change in field strength will not change the power output but will change the reactive component (ie the kVAR). Suppose two machines run in parallel both with perfect AVRs, ie AVRs that ensure the output voltage is correct whatever the current or power factor.

If one machine supplies a low power factor lagging current I_1 , an AVR with no compounding will raise the field mmf to counteract. The other machine will supply a leading current I_2 such that the vector sum of the two machine currents equals the load current I . The AVR of each machine adjusts the field mmf to keep the total mmf in the field constant for the set point voltage. A change in the reactive component in either machine can avalanche as the AVRs try to correct.

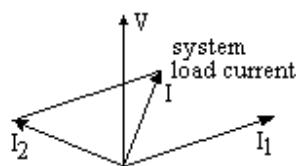

One of two things will happen;

(1) The lagging reactive current in one set will rise balanced by a rise in the leading reactive current in the other set. The current in both machines will steadily rise till the ammeters go off the scale and the machines trip on overload.

Or (2) the lagging reactive component will swing violently from one set to the other till again the machines trip on overload. One or other of these is a common fault when commissioning a new alternator set and indicates reversed or incorrectly set compounding.

To prevent this happening, a “droop” is introduced in the AVR circuit. A lagging current must slightly reduce the excitation. Thus a lagging current must slightly increase the voltage seen by the AVR which will then reduce the excitation. Conversely a leading current slightly reduces the voltage seen by the AVR which then increases the excitation.

Somewhere between these two extremes of power factor, there is a power factor where the current does not change the voltage. The circuitry is arranged so that this occurs at the design system power factor, ie the expected power factor of the load to be connected to the generator. At this design system power factor, the voltage is correct whatever the current.

If the expected system power factor is close to 0.87 (ie $\cos 30^\circ$), then the reference voltage for the AVR could be the vector relation;

$$V_{AVR} = V_{yellow} + I_{red} \times R$$

At a power factor of $\cos 30^\circ$ lagging, the current vector I_{red} (and hence compounding voltage $I_{red} R$) is at right angles to the voltage vector V_{yellow} .

At a power factor of zero lagging, V_{AVR} is greater than V_{yellow} , hence the AVR reduces the field giving the droop.

The $I_{red} \times R$ term is called the compounding.

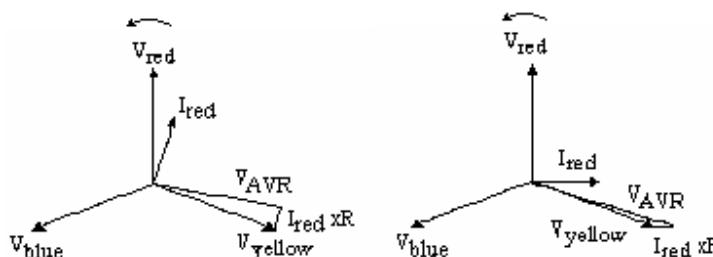

Compounding for any other expected system power factor can be arranged by using an AVR that accepts a DC reference voltage. The compounding voltage is added to the reference voltage by vector addition with a 90° phase shift, (eg blue to yellow phase volts added to a compounding voltage proportional to red phase current. This modified reference voltage is then rectified. An adjustable rectified voltage proportional to the compounding voltage is then subtracted from the reference voltage (ie a vector addition followed by a scalar subtraction) so that at the design system power factor, the reference voltage is the same whatever the current.

For the very best voltage control system, the reference voltage for the AVR is the DC sum of the three phase or line voltages, each with the appropriate compounding. This has the advantage that the alternator response is the same with unbalanced load or single phase fault regardless of which phase carries the heavy current.

Over and under excitation

If the alternator supplies a lagging load, the excitation must be increased to partly overcome the demagnetizing effect of the load current but not enough to completely overcome it.. The machine is said to be overexcited and the emf is greater than the voltage.

If the machine supplies a leading current, the machine is said to be underexcited and the emf is less than the voltage.

Stability

The stability depends on the angle between E and V

Power per phase $P = VI \cos \phi$

From Sine formula

$$IX / \sin\theta = E / \sin(90 + \phi)$$

$$I = E \sin\theta / X \cos\phi$$

$$P = (VE/X) \sin\theta$$

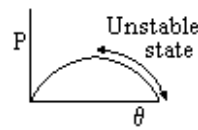
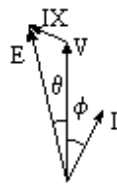



360°
thinking.

Discover the truth at www.deloitte.ca/careers

Deloitte.

© Deloitte & Touche LLP and affiliated entities.



Salient Pole Alternator

Power per phase $P = VI \cos \phi$
 $= V(I_q \cos \theta + I_d \sin \theta)$

$E = V \cos \theta + I_d X_d$

$V \sin \theta = I_q X_q$

$P = (EV/X_d) \sin \theta + [V^2 (X_d - X_q) \sin 2\theta] / [2X_d X_q]$

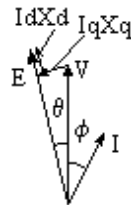

The distortion of the curve is due to the second harmonic term. Maximum power occurs much earlier and the angle between E and V is considerably reduced.

A turbo cannot produce any power by excitation of the armature only. A salient pole machine can produce 10% of full power without excitation. Flux in the air gap is normal to the pole face but fringe flux at the edge of the pole can produce the torque.

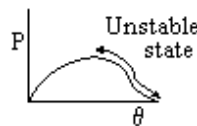

Transient Stability

If the machine is operating in the stable region and an additional load is applied, the equilibrium condition may move closer to the unstable region. If this load is applied suddenly, the machine may overshoot into the unstable region and will then cease to operate.

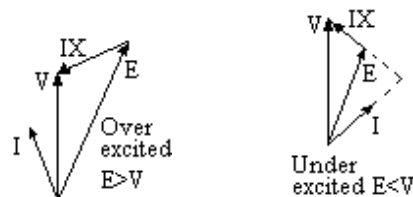

Synchronous Motor

With a synchronous motor, the currents are the opposite direction.

$V = E + IX$

If the emf exceeds the voltage, the current leads the voltage. If the emf is less than the voltage, then the current lags the voltage. This is the opposite of the alternator so it is confusing to refer to the currents only as leading or lagging.

The power factor of an industrial plant which has many induction motors can be improved by installing one or more synchronous motors.

Synchronous Condenser.

The synchronous condenser is neither a generator nor a motor. The current is zero power factor. If the machine is over-excited, it can be considered as an alternator generating a lagging current. Equally it can be considered a motor taking a leading current. If the machine is under-excited, it can be considered as an alternator generating a leading current. Equally it can be considered a motor taking a lagging current.

A synchronous condenser is used to improve the power factor of an industrial plant. It is described as over or under excited, not as taking a leading or lagging current.

MMF due to a three phase winding

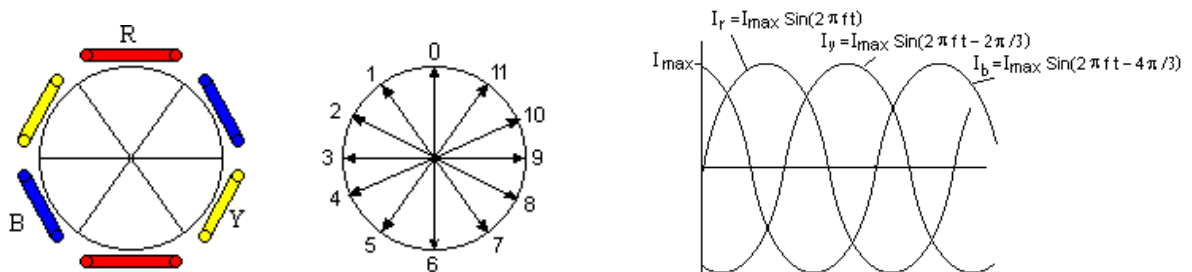

Consider a three phase winding Red, Yellow and Blue spaced at 120° with N turns per phase

Let F_r = mmf due to R winding, F_y = mmf due to Y winding and F_b = mmf due to B winding

$$F_r = I_{\max} N \sin \theta \text{ ampere turns,}$$

$$F_y = I_{\max} N \sin (\theta - 2 \pi / 3)$$

$$F_b = I_{\max} N \sin (\theta - 4 \pi / 3)$$

$$\text{where } \theta = 2 \pi f t$$

Let F_0, F_1, F_2 etc be the net mmfs resolved along axes 0, 1, 2 etc

$$F_0 = F_r - F_y \sin(\pi / 6) - F_b \sin(\pi / 6) = F_r - \frac{1}{2} F_y - \frac{1}{2} F_b$$

$$F_1 = \frac{\sqrt{3}}{2} F_r - \frac{\sqrt{3}}{2} F_y$$

$$F_2 = \frac{1}{2} F_r - F_y + \frac{1}{2} F_b$$

$$F_3 = -\frac{\sqrt{3}}{2} F_y + \frac{\sqrt{3}}{2} F_b$$

$$F_4 = -\frac{1}{2} F_r - \frac{1}{2} F_y + F_b$$

$$F_5 = -\frac{\sqrt{3}}{2} F_r + \frac{\sqrt{3}}{2} F_b$$

$$F_6 = -F_r + \frac{1}{2} F_y + \frac{1}{2} F_b$$

Theta	F0	F1	F2	F3	F4	F5	F6
0	1.5	1.3	0.75	0	-0.75	-1.3	-1.5
$\pi / 6$	1.3	0.75	0	-0.75	-1.3	-1.5	-1.3
$\pi / 3$	0.75	0	-0.75	-1.3	-1.5	-1.3	-0.75
$\pi / 2$	0	-0.75	-1.3	-1.5	-1.3	-0.75	0
$2 \pi / 3$	-0.75	-1.3	-1.5	-1.3	-0.75	0	0.75
$5 \pi / 6$	-1.3	-1.5	-1.3	-0.75	0	0.75	1.3
π	-1.5	-1.3	-0.75	0	0.75	1.3	1.5

Thus the mmf rotates at a frequency f with a magnitude $F_{max} = (3/2)(N I_{max})$ ampere turns

The mmf due to the three phase winding resolved in one direction is $F = (3/2) N I_{max} \sin(\omega t + \alpha)$ where $\omega = 2\pi f/p$ and α is a constant that depends on the direction of the mmf when $t = 0$.

$$F_{max} = \frac{1}{2} c Z \sqrt{2} I \text{ Ampere Turns/pole/phase}$$

where $c = \text{slots/pole/phase}$, I is the rms value and $Z = \text{conductors/slot}$

If a three phase winding rotates between pole faces, the mmf follows the pattern shown

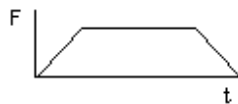

When $\omega t = 90^\circ$

$$I_r = I_p$$

$$I_y = I_p \sin(-30) = -I_p/2$$

$$I_b = I_p \sin(-150) = -I_p/2$$

When $\omega t = 90^\circ$, the flux distribution is as shown

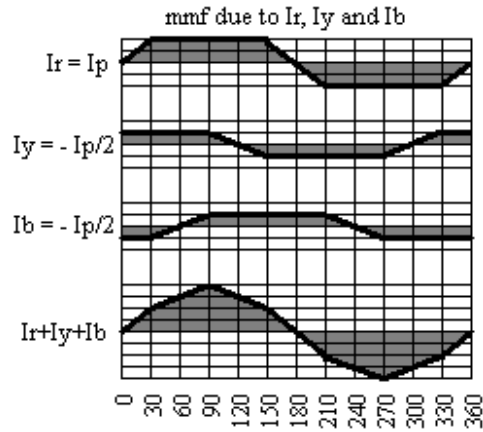

When $\omega t = 120^\circ$

$$I_r = \sqrt{3}/2 I_p$$

$$I_y = I_p \sin(0) = 0$$

$$I_b = I_p \sin(-120) = -\sqrt{3}/2 I_p$$

When $\omega t = 120^\circ$, flux distribution is as shown

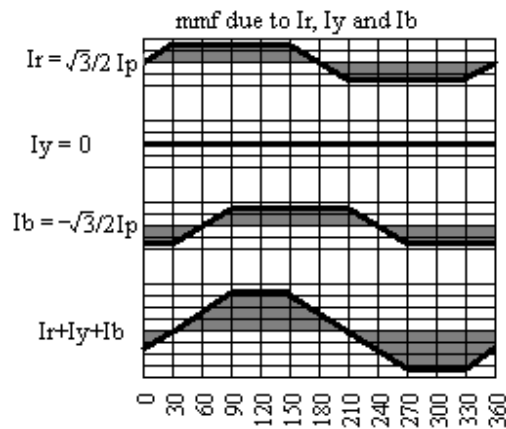

Thus when ωt changes from 90° to 120° , the centre of the flux rotates by 30° electrical degrees.

MMF including harmonics due to a three phase winding in slots

$$F = (4/\pi) F_{MAX} (3/2) [k_{1D} \sin(\theta - \omega t) + (k_{5D}/5) \sin(5\theta - \omega t) + (k_{7D}/7) \sin(7\theta - \omega t) + \dots]$$

AC Induction Motors

Small AC commutator motors

Small AC motors (eg for hand tools) are usually commutator machines with the field connected in series. There is a transformer effect between the field and armature which prevents the motor having a shunt connected field.

Three phase Induction Motors

The majority of AC motors are three phase induction motors. The stator is wound with three coils spaced equally round the stator. When these coils are connected to a three phase supply, they create a magnetising force that rotates at synchronous speed in the rotor. The synchronous speed is the supply frequency divided by the number of pairs of magnetic poles. Thus the synchronous speed for a 4 pole machine is 1500 rpm on a 50 cps supply.

The rotors consist of a cage of bars solidly connected together at each end. Hence a common name for the rotor is “squirrel cage”.

Swapping any two phases causes the rotating field to reverse direction. Hence to change the direction of rotation, swap any two phases.

SIMPLY CLEVER ŠKODA 

We will turn your CV into
an opportunity of a lifetime



Do you like cars? Would you like to be a part of a successful brand?
We will appreciate and reward both your enthusiasm and talent.
Send us your CV. You will be surprised where it can take you.

Send us your CV on
www.employerforlife.com

The rotating field induces an emf in the rotor at “slip” frequency, (ie at a frequency equal to the synchronous speed minus the rotor speed).

$$\text{Slip } \Sigma = (n_0 - n)/n_0$$

where n_0 is the synchronous speed and n is the actual speed.

The emf induced in the rotor is proportional to the slip frequency.

$$E = \Sigma E_0 \text{ where } E_0 \text{ is the emf at slip} = 1$$

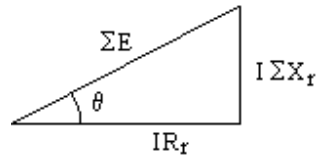

Let the Rotor resistance and reactance be R_r and X_r at supply frequency.
Hence the rotor resistance and reactance at slip frequency are R_r and ΣX_r

The rotor current is I shown on the vector diag where;

$$\theta = \text{Arc Sin} (I X_r / E)$$

Suppose a resistance ρ is added to the rotor resistance and the load adjusted (if necessary) to maintain the current at I . The motor will run more slowly.

With added resistance ρ the slip becomes Σ' .

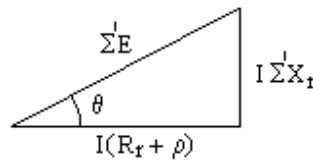

The vector diag becomes as shown.

The phase angle of the current is unchanged

$$\text{at } \theta = \text{Arc Sin} (I X_r / E)$$

With I and θ unchanged, the magnetic force on each conductor is unchanged, and therefore the torque is unchanged.

Furthermore, since the rotor current magnitude and phase angle are unchanged, the stator current is unchanged in magnitude and phase angle.

Hence by adding resistance to the rotor, nothing is changed except the slip and the speed.

Equating values for $\text{Cos } \theta$,

$$I R_r / \Sigma E = I (R_r + \rho) / \Sigma' E$$

Hence $\Sigma' / \Sigma = (R_r + \rho) / R_r$

Thus Slip is proportional to rotor resistance.

As more resistance is added, the slip increases. We can add resistance till the slip = 1, ie the motor comes to a standstill. Let the resistance for standstill be ρ'

Putting $\Sigma' = 1$ in the value of $\cos \theta$ gives

$$1/\Sigma = (R_r + \rho) / R_r$$

$$\rho' = R_r (1 - \Sigma) / \Sigma$$

where Σ is the slip under normal running conditions.

$$R_r + \rho' = R_r / \Sigma$$

The only difference between the condition at standstill and at full load is that in one case there is mechanical power output and in the other this same amount of power is consumed by $I^2 \rho'$. Thus $I \rho'$ is equal to the back emf at full load and $I^2 \rho'$ is equivalent to the output power per phase. There are three phases so the total power output is $3 I^2 \rho'$ watts where $\rho' = R_r (1 - \Sigma) / \Sigma$ and Σ is the slip at full load.
Power output = $3 I^2 R_r (1 - \Sigma) / \Sigma$

The motor at standstill has become a transformer. The rotor and stator resistances and reactances can be lumped together as a single resistance and reactance with the appropriate turns ratio. Current is required to magnetise the field and this is added vectorially.

Let R be the total equivalent resistance of the stator and magnetising circuit and X be the total equivalent reactance of the rotor, stator and magnetising circuit. Then $I = V / Z = V / \sqrt{[(R + R_r + \rho')^2 + X^2]}$

$$I = V / \sqrt{[(R + R_r / \Sigma)^2 + X^2]}$$

But Σ is small, therefore R_r / Σ is large compared to R

$$I \approx V / \sqrt{[(R_r / \Sigma)^2 + X^2]}$$

Power output

$$P \approx 3 V^2 / [(R_r / \Sigma)^2 + X^2] R_r (1 - \Sigma) / \Sigma$$

$$P \approx 3 V^2 (1 - \Sigma) R_r \Sigma / [R_r^2 + X^2 \Sigma^2] \text{ watts}$$

Let the output torque be T newton metres

$$P = 2\pi T (1 - \Sigma) n_0 \text{ watts}$$

$$T \approx 3 V^2 R_r \Sigma / [2\pi n_0 (R_r^2 + X^2 \Sigma^2)]$$

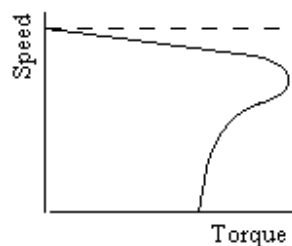

Plotting T against Σ gives the speed torque curve for an induction motor.

The Speed for maximum torque is given by

$$dT/d\Sigma = 0$$

$$T = A\Sigma / [R_r^2 + X^2 \Sigma^2]$$

$$\text{where } A = 3 V^2 R_r \Sigma / [2\pi n_0]$$

$$\begin{aligned}
 dT/d\Sigma &= A[R_r^2 + X^2 \Sigma^2]^{-1} \\
 &\quad + A\Sigma[R_r^2 + X^2 \Sigma^2]^{-2}(-1)(2 X^2 \Sigma) \\
 &= A[R_r^2 + X^2 \Sigma^2]^{-2}[R_r^2 + X^2 \Sigma^2 - 2 X^2 \Sigma^2] \\
 &= A[R_r^2 + X^2 \Sigma^2]^{-2}[R_r^2 - X^2 \Sigma^2] \\
 dT/d\Sigma &= 0 \text{ when } R_r^2 = X^2 \Sigma^2 \\
 \text{ie when } \Sigma &= R/X \\
 d^2T/d\Sigma^2 &= (-2) A[R_r^2 + X^2 \Sigma^2]^{-3}[R_r^2 - X^2 \Sigma^2] \\
 &\quad + A[R_r^2 + X^2 \Sigma^2]^{-2}[- 2X^2 \Sigma] \\
 \text{when } R_r^2 &= X^2 \Sigma^2, d^2T/d\Sigma^2 \text{ is negative}
 \end{aligned}$$

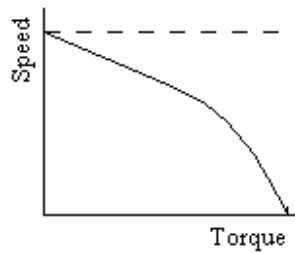

Therefore T is a maximum when $\Sigma = R_r/X$

If $R_r = X$ the torque is a maximum when the speed is zero. This makes the motor inefficient at full load, but a wound rotor with slip rings and a variable external resistance are sometimes used where a high starting torque is required.

I joined MITAS because
I wanted **real responsibility**

The Graduate Programme
for Engineers and Geoscientists
www.discovermitas.com

Month 16

I was a construction supervisor in the North Sea advising and helping foremen solve problems

Real work
International opportunities
Three work placements



Induction motors are usually started direct on line, ie the starter switches the supply directly to the winding. Small motors typically take about six times full load current for five or six seconds. Large motors take four or five times full load current for as long as fifteen seconds.

However the starting current is low power factor until the motor is almost up to speed so the current taken from the supply is more likely to be a problem than power taken from the supply. Motors are normally kept on light load till up to speed.

Single phase induction motors

Single phase induction motors start on two phases from a single phase supply. One of the phases has an impedance in series to change its phase. This is often a large capacitance connected through a centrifugal switch which cuts out the capacitance when the motor is up to speed.

Some small motors use a short circuited coil permanently flux linked with one winding. This changes the phase angle of this winding enough for the motor to start and run.

Power Factor Improvement

AC Induction motors have inductive coils connected to the supply. The power factor is poor, typically in the range 0.7 to 0.9, usually the lower end. This means that the power loss in the supply to the motor is relatively high. The power factor can be improved by the installation of a bank of capacitors in parallel with the motor. Ideally, the capacitive reactance should be the same as the inductive reactance which would bring the power factor up to unity.

A synchronous motor is an alternative to a bank of capacitors. The synchronous motor can be over excited to take a leading current and can either be used as a motor or run light purely for power factor improvement.. The downside is that synchronous motors are more difficult to start and in the event of a system fault may lose synchronism further adding to the disruption.

Speed control of ac motors

Speed control of ac motors is possible by thyristor control of the current or voltage. Another method is to rectify the ac into dc and use the dc to power an inverter to give a variable frequency ac supply. This is the subject of another e-book.

Insulation

Insulation for electrical machines.

Insulating materials for electrical machines are grouped into several classes.

Class A is organic, eg cotton, linen etc

Class B is inorganic, eg mica, glass, asbestos etc, and is usually impregnated with varnish.

The permitted temperature rise depends on the Class

Class Y	Class A	Class E	Class B	Class F	Class H	Class C
90° C	105° C	120° C	130° C	155° C	180° C	>180° C

Electrical machines are designed such that the hottest spot in the machine is within the permitted temperature for the Class of insulation when operating on full load in an ambient of 40° C.

It follows that at higher ambient temperatures, the rating of the machine is reduced, while at lower ambient temperatures the machine may be operated on a higher load without overheating. At given voltage, power output is approximately proportional to current while copper loss is proportional to the square of the current. Total loss is proportional to the temperature difference between the insulation and ambient temperatures.

Let T_1 be the permitted temperature for the Class of insulation and T_2 the ambient temperature. Let Q be the ratio of the friction, windage and iron loss to the copper loss at full load.

Thus $Q = (\text{Watts input on no load}) / (I^2 R \text{ loss on full load})$

Power Output at ambient temp T_2

$$= \text{Rated Output} \times \sqrt{[Q(40 - T_2)/(T_1 - 40) + (T_1 - T_2)/(T_1 - 40)]}$$

The average winding temperature can be measured by the resistance of the winding. The hot spot temperature will be about 10% higher. If the machine is operated above the permitted temperature, the life of the insulation will be shortened. The effect is logarithmic. For a long life, the machine should be operated well below the permitted temperature.

Class	Class A	Class E	Class B	Class F	Class H
Permitted	105° C	120° C	130° C	155° C	180° C
10 year life	102° C	116° C	125° C	150° C	174° C
5 year life	112° C	126° C	134° C	160° C	188° C
1 year life	128° C	145° C	152° C	178° C	206° C

Insulation Resistance depends on the temperature and the relation is logarithmic. Typically an increase of 65 degrees C causes the insulation resistance to be reduced to one tenth in value.

Transformers

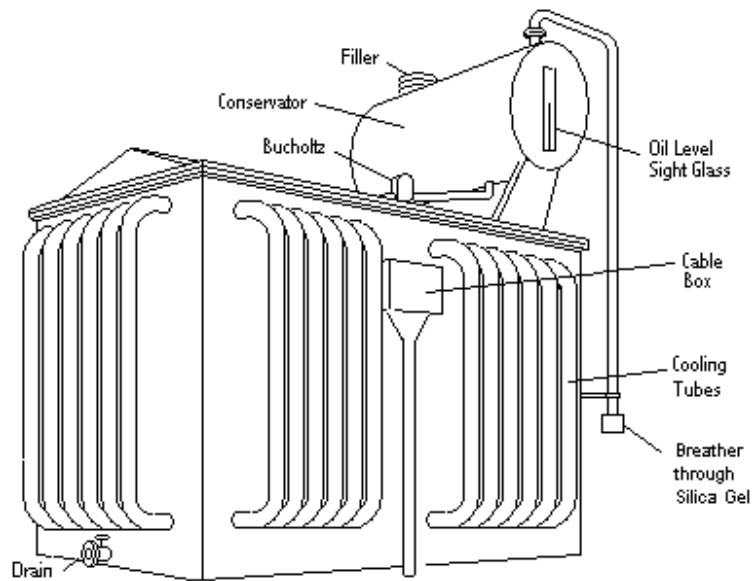

"I studied English for 16 years but...
...I finally learned to speak it in just six lessons"
Jane, Chinese architect

ENGLISH OUT THERE

Click to hear me talking before and after my unique course download

The advertisement features a woman with sunglasses on her head, smiling. The background is a blurred world map. A green speech bubble contains the text 'ENGLISH OUT THERE'. Below it, there is a call to action: 'Click to hear me talking before and after my unique course download'.



Power transformers in electricity supply systems

Transformers are widely used in electrical power supplies. The power loss in the electrical power supply is $I^2 R$, but the power transmitted is $\sqrt{3} V I \cos \phi$. Thus for a given conductor size, the loss is inversely proportional to V^2 .

Electrical power transmission is therefore at high voltage eg 400 kV or 230 kV. The voltage is then reduced to a more manageable value typically 11kV, 33 kV or 66 kV. Finally it is reduced again to about 415 volts to give single phase supplies of about 240 volts.

Construction of power transformers

Power transformers are usually oil filled with cooling fins or tubes. The windings are usually wound on a winding machine from strip copper wrapped with paper insulation. The winding on each limb is completed as a number of discs. The core consists of steel laminations, each of which has an insulating material baked on one side. The laminations are assembled with overlapping joints and the top left open.

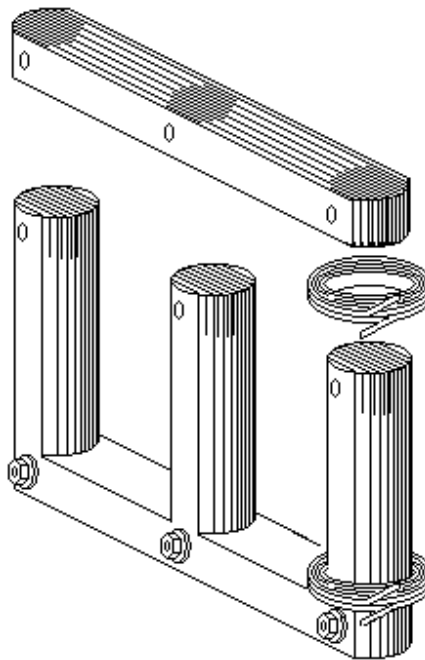

The winding discs are placed on each limb of the core and the top laminations of the core are then fitted with interleaving joints. The connections between the winding discs are made and the windings compressed rigid. The top of the transformer tank is then fitted to the core and any bushings connected to the windings. The assembly is then lowered into the tank and connections made to any cable boxes. The tank top cover is bolted to the tank with an oil tight gasket. When complete, the transformer internals hang from the tank top. The complete transformer is often baked in an oven to thoroughly dry out the paper insulation before filling with oil. The conservator, an oil filled header tank, allows for the expansion and contraction of the oil with a vent to atmosphere through silica gel.

Core Arrangements

3 Phase Power Transformers usually have the Primary connected in Delta and the Secondary connected in Star on a 3 Limb Core. If both windings are connected in Star, then the Core may be 5 Limb.

Single Phase Power Transformers are usually Shell type.

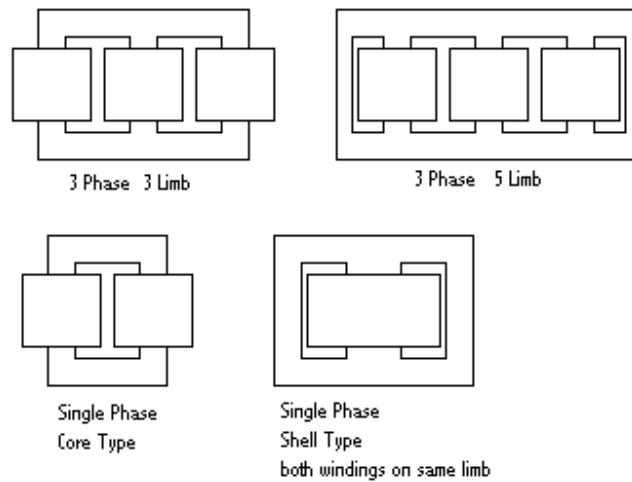

Flux

The flux $\Phi_{\max} = [4 \pi \mu A I_{\max} N / L] \times 10^{-7}$ weber.

where μ is the permeability of the core, A is the cross sectional area of the core in m^2 , I_{\max} is the peak value of the magnetizing current in amps, N is the number of turns and L is the length of the magnetic path in the core in metres.

Back emf

The AC supply causes a sinusoidal magnetising force which in turn causes a flux in the iron core.

Let the flux be $\Phi = \Phi_{\max} \cos(2\pi f t)$

The back emf on a winding of N turns linked with this flux is;

$$E = -N \frac{d\Phi}{dt}$$

$$E = N \Phi_{\max} 2\pi f \sin(2\pi f t)$$

Hence $E_{\text{rms}} = (1/\sqrt{2}) N \Phi_{\max} 2\pi f$

$$E_{\text{rms}} = 4.44 N \Phi_{\max} f$$

where Φ_{\max} is in webers, f is in Hz and E_{rms} is in volts

Delta / Star transformation

The primary winding is usually connected in delta and the secondary in star with the secondary neutral brought out to a terminal. The secondary current times turns on each limb of the transformer is balanced by an equal number of current times turns on the primary. The primary also carries a low power factor lagging current to provide the magnetising force.

There are two possible connections. In one the secondary voltage leads the primary by 30° and in the other the secondary voltage lags the primary by 30° .

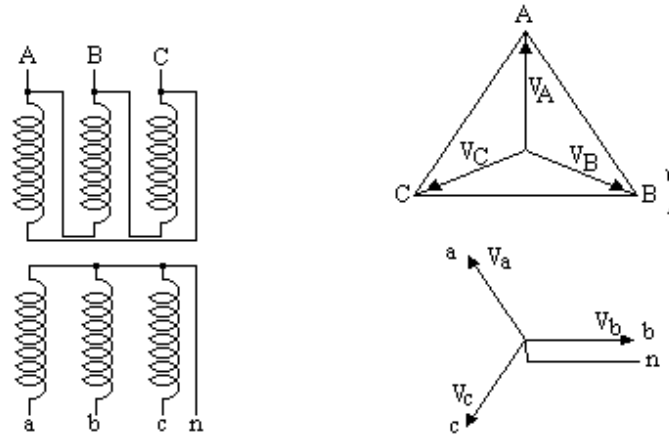

Star / Star transformation

Very high voltage primaries are sometimes connected in star as all the high voltage connections are then at the top of the transformer. The three phase primary supply does not normally have the neutral connected. This means that there is no circuit on the primary to balance a single phase load on the secondary. A third delta connected winding is usually fitted on a star/star transformer, ie the transformer is star/delta/star. Current circulating in the delta winding allows the transformer to supply a single phase or unbalanced secondary load.

WHILE YOU WERE SLEEPING...

The CD-ROM cover features several news headlines: "DIAN NUCLEAR WATER CORP", "RUSSIAN ENTREPRENEUR", "LUXURY GOODS MARKET LONDON", "TROUBLED LONDON B", "CHINA PAYS REMIUM FINI", "AFRICA HEALS PLI", "US FIRM PLI", and "LONDON B".

www.fuqua.duke.edu/whileyouweresleeping

DUKE
THE FUQUA
SCHOOL
OF BUSINESS



Measurement of losses and efficiency of a power transformer.

The rated primary AC voltage is applied to the primary with the secondary open circuit. A voltmeter, ammeter and wattmeter are fitted to measure the primary input. The instruments measure the magnetising current and iron loss, ie hysteresis and eddy current loss at full volts, as the copper loss is negligible.

These give the magnitude and power factor of the magnetising current.

The DC resistance of the primary and secondary windings are measured in another test.

A variable AC voltage is then applied to the primary with the secondary short circuited or alternatively the voltage is applied to the secondary with the primary short circuited. Either way, the current is raised to the rated value. The input voltage, current and power loss are measured. The voltage and current give the impedance and the wattmeter gives the total copper loss as iron loss is negligible. The voltage is the Full Load Impedance Voltage.

The total copper loss is proportioned to the primary and secondary in the ratio of their DC resistances to obtain the primary and secondary copper loss. Hence the primary and secondary AC Resistances can be obtained., each is $R = W / I^2$.

The open circuit test establishes the magnitude and power factor of the magnetising current. On full load, the primary winding carries the vector sum of the load current and the magnetising current while the secondary winding carries only the load current. Thus the copper loss in the primary and secondary at full load can be calculated. The total loss = total copper loss plus iron loss.

If the transformer is three phase, the Output Power = $\sqrt{3} V I \cos \phi$.

If single phase. The Output Power is $V I \cos \phi$.

The efficiency at rated current and rated power factor can now be obtained. The efficiency = Output Power / (Output Power + Total Loss)

The Impedance Volts % = (Full Load Impedance Volts x 100) / (Rated Volts)

If required, the efficiency at part load and/or different power factors can be obtained by the same method.

If required, the magnetising current magnitude and power factor can be obtained at lower voltage by the open circuit test carried out at the lower voltage. The curve of AC voltage against current follows roughly the pattern of the B – H curve for the core.

Transformers are often installed as a duplicate pair each with tap changers. In this case, the transformers can be tested at full load current and voltage by operating them in parallel on different tap settings.

Inrush of the magnetising current

When the transformer is switched on, the magnetic flux builds up through the hysteresis loops. If the transformer has been recently switched off, there may be very significant residual magnetism in the core. If the transformer is switched on at the instant when the magnetising force is exactly out of phase with the residual magnetism, the core may become very oversaturated. In this case the self inductance of the winding becomes very low and the magnetising current very high. An initial magnetising current exceeding full load current can occur but will subside to normal within a second. I have seen the ammeter needle bent by the inrush of the magnetising current as the needle hit the stops.

Unbalanced loads

If the load is not balanced three phase, the primary current is related to the secondary by the turns ratio, not by the voltage ratio. Consider each limb of the transformer and convert the secondary current to primary for that limb. Add the primary current on all limbs connected to each phase to get the primary current in that phase.

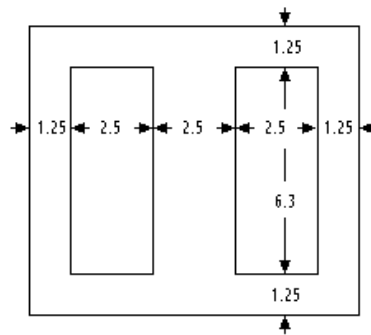
Example

The diagram shows the size of the stampings for a transformer core. The dimensions are in cms and the core is 2.5 cms thick.

Stacking factor 0.9

Peak B = 1 Tesla

Space factor for the copper = 0.45

Current density in copper = 2 A/mm²

Input voltage = 230 volts Output voltage = 6.3 volts

Calculate the maximum rating and the sizes of wire.

Cross Sectional Area of the flux path = $2.5 \cdot 2.5 \cdot 0.9 = 5.62 \text{ cm}^2$

Peak flux $\Phi_{\max} = 5.62 \text{ E-4 weber}$

$E = 4.44 \text{ N } \Phi_{\max} f = 4.44 \cdot 5.62 \cdot 50 \cdot \text{N} / 10000 = 0.125 \text{ N}$

Thus the coils have 8 turns/volt

The 230 volt winding has 1840 turns

The 6.3 volt winding has 50.4 turns, say 51

Allow 1.5 mm all round the window.

The window area for the windings is $6.0 \cdot 2.2 = 13.2 \text{ cm}^2$

Net cross section of the copper is $13.2 \cdot 0.45 = 5.94 \text{ cm}^2$

Cross section for each winding is 297 mm^2

Max current in the 230 volt winding is $2 \cdot 297 / 1840 = 0.32 \text{ amps}$

Hence the rating of the transformer = $230 \cdot 0.32 = 74 \text{ VA}$

Wire for the 230 volt winding is $297/1840 = 0.16 \text{ mm}^2 = 26 \text{ SWG}$

Wire for the 6.3 volt winding is $297 / 51 = 5.82 \text{ mm}^2$

or 4 coils in parallel of 17 SWG enamelled wire

Excellent Economics and Business programmes at:



**university of
 groningen**



**“The perfect start
 of a successful,
 international career.”**

CLICK HERE
 to discover why both socially
 and academically the University
 of Groningen is one of the best
 places for a student to be

www.rug.nl/feb/education



Rectifiers

High power rectifiers

High power rectifiers provide a high power DC supply, eg for charging a large bank of batteries, for DC traction motors, electric furnaces and similar applications.

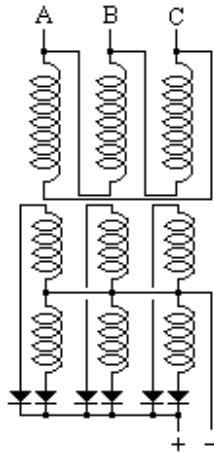

Rectifiers are usually semi conductor devices which are now replacing the old mercury arc rectifiers, see the book on Power Electronics.

The six anodes are connected to the six terminals of a dedicated transformer with two windings on each limb.

Alternatively the rectifier can be supplied from an interconnected star transformer. Let the turns ratio of the transformer be 1:N

$$V_1 = N(V_A - V_B)$$

$$V_2 = N(V_A - V_C)$$

$$V_3 = N(V_B - V_C)$$

$$V_4 = N(V_B - V_A)$$

$$V_5 = N(V_C - V_A)$$

$$V_6 = N(V_C - V_B)$$

V1 to V6 are six phases spaced at 60° between phases.

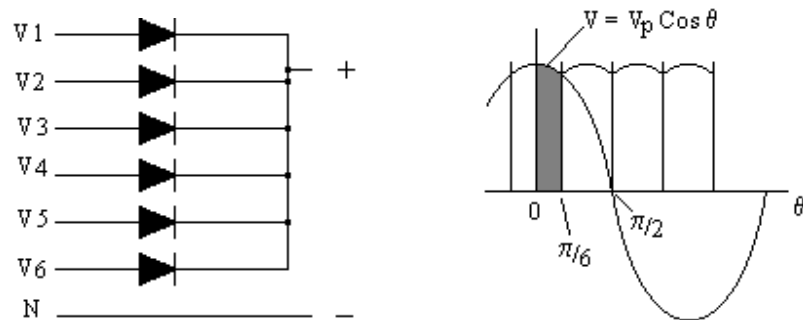
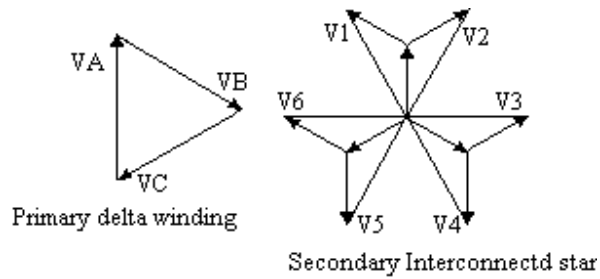

Average DC output voltage = shaded area divided by $(\pi / 6)$

$$\begin{aligned} V &= (6/\pi) \int V_p \cos \theta d\theta \text{ from } 0 \text{ to } \pi/6 \\ &= (6/\pi) V_p \sin \theta \text{ from } 0 \text{ to } \pi/6 \\ &= (6/\pi) V_p [\sin \pi/6 - \sin 0] \\ &= (6/\pi) V_p (1/2) \\ &= 3 V_p / \pi = 0.955 V_p \end{aligned}$$

where V_p is the maximum phase voltage of the six phase supply

Three phase rectification of phase voltages

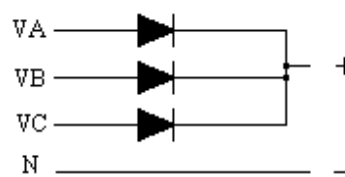

Supply from 3 phase voltages spaced $2\pi/3$

Average DC voltage

$$\begin{aligned} V &= (3/\pi) \int V_p \cos \theta d\theta \text{ from } 0 \text{ to } \pi/3 \\ &= (3/\pi) V_p \sin \theta \text{ from } 0 \text{ to } \pi/3 \\ &= (3/\pi) V_p [\sin \pi/3 - \sin 0] \\ &= (3/\pi) V_p \sqrt{3} / 2 = 0.827 V_p \end{aligned}$$

where V_p is the maximum phase voltage of the three phase supply

Three phase rectification of line voltages

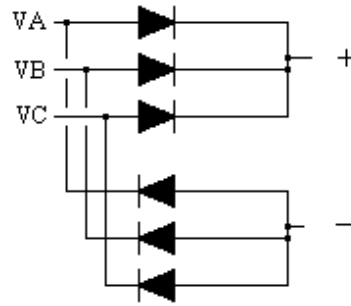

Supply from 3 line voltages spaced $2\pi/3$

As above

Average DC voltage

$$V = 0.827 V_p$$

where V_p is the maximum line voltage of the three phase supply

.....Alcatel-Lucent

www.alcatel-lucent.com/careers

What if you could build your future and create the future?

One generation's transformation is the next's status quo. In the near future, people may soon think it's strange that devices ever had to be "plugged in." To obtain that status, there needs to be "The Shift".

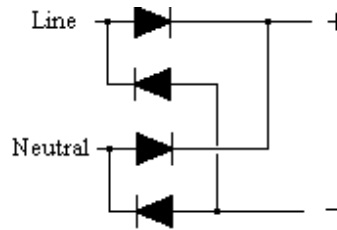

Single phase full wave rectification

Average DC voltage

$V =$ Average value of half a sine wave

$$= 0.636 V_p$$

where V_p is the maximum voltage of the single phase AC supply

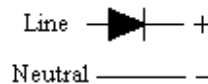
Single phase half wave rectification

Average DC voltage is half full wave value

$$V = 0.318 V_p$$

where V_p is the maximum voltage of the AC supply

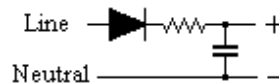
Capacitance in the DC circuit

A capacitance in the DC circuit can raise the DC voltage to the maximum (ie peak) value of the AC voltage.

A current limiting device (eg a resistor) is usually fitted between the rectifier and the capacitance otherwise the high initial charging current of the capacitance can damage the rectifier. If there is no DC load, the voltage across the capacitance rises till it reaches the peak value of the supply.

With a DC load, the current flows from the supply only when its voltage exceeds the capacitance voltage. Thus when there is a DC load, the voltage across the capacitance falls to allow current to flow from the supply. The resistor increases the voltage drop even more.

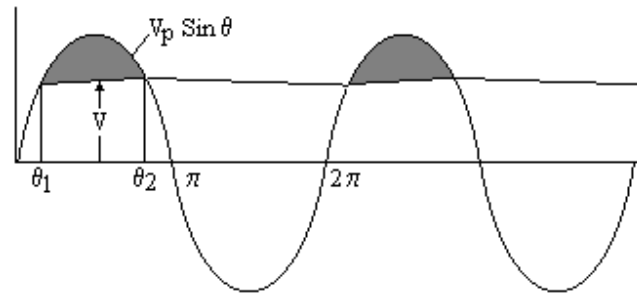

In the diagram, V is the voltage across the capacitance.

Assume the capacitance is large enough for V to be considered constant.

The current flowing from the supply between θ_1 and θ_2 is

$$i = [V_p \sin \theta - V] / R$$

The total quantity of electricity flowing from the supply in one cycle is proportional to the shaded area.

$$Q = \int [V_p \sin \theta - V] / R d\theta$$

But this is the same as the total quantity of electricity flowing in the load in one complete cycle

$$= I_{DC} 2\pi \text{ where } I_{DC} \text{ is the DC load current.}$$

$$\begin{aligned} I_{DC} 2\pi &= [-V_p \cos \theta - V\theta] / R \text{ from } \theta_1 \text{ to } \theta_2 \\ &= 2[-V_p \cos \theta - V\theta] / R \text{ from } \theta_1 \text{ to } \pi/2 \\ &= 2[-V_p \cos(\pi/2) - V(\pi/2) + V_p \cos \theta_1 + V\theta_1] / R \\ &= 2[-V(\pi/2 - \theta_1) + V_p \cos \theta_1] / R \end{aligned}$$

But $V_p \sin \theta_1 = V$

$$V_p \cos \theta_1 - V_p \sin \theta_1 (\pi/2 - \theta_1) = \pi R I_{DC}$$

Hence θ_1 can be evaluated and hence $V = V_p \sin \theta_1$

Capacitance in DC output from a multi phase rectifier

Let the supply have Z phases

Then in one cycle, current input = Z times current input of each phase

Other parameters being equal, DC current per phase = I_{DC} / Z

where I_{DC} is the total DC current.

$$\text{Hence } V_p \cos \theta_1 - V_p \sin \theta_1 (\pi/2 - \theta_1) = \pi R I_{DC} / Z$$

Evaluate θ_1 and put $V = V_p \sin \theta_1$

For example

CLS

INPUT "Enter the RMS value of the supply "; Vrms

INPUT "Enter number of phases in the supply "; Z

INPUT "Enter the series resistance "; R

INPUT "Enter the average DC current "; Idc

$$V_p = \text{SQR}(2) * V_{rms}$$

$$X_{min} = 0 : X_{max} = 3.14159/2 : S = 0.1$$

100 '

Flag = 0

FOR X = Xmin TO Xmax STEP S

$$E = (V_p * \text{COS}(X) - V_p * \text{SIN}(X) * (3.14159/2 - X)) - (3.14159 * R * I_{dc} / Z)$$

```

IF X = 0 AND E < 0 THEN PRINT "Resistance too high for output current"
IF X = 0 AND E < 0 THEN END
IF E < 0 AND Flag = 0 THEN NewXmin = X - S : Flag = 1
NEXT X
Xmin = NewXmin : Xmax = NewXmin + S : S = S/10
IF S > 0.00001 THEN 100
PRINT "X = " ; (Xmin + Xmax) / 2 ;
PRINT "DC voltage = " ; Vp * SIN((Xmin + Xmax)/2)

```

Harmonics due to rectifiers

The dc output from a rectifier is often smoothed by a series inductance. The rectifier then draws a square wave from the supply. The square wave will contain harmonics. If the rectifier is high power or the load contains many rectifiers, eg computer terminals, the harmonics can cause problems in the system.. However the load can be analysed by Fourier analysis to obtain the magnitude of each harmonic as the example on generator harmonics, as shown in the example on page 108.



Maastricht University

Leading in Learning!

Join the best at the Maastricht University School of Business and Economics!

Top master's programmes

- 33rd place Financial Times worldwide ranking: MSc International Business
- 1st place: MSc International Business
- 1st place: MSc Financial Economics
- 2nd place: MSc Management of Learning
- 2nd place: MSc Economics
- 2nd place: MSc Econometrics and Operations Research
- 2nd place: MSc Global Supply Chain Management and Change

Sources: Keuzegids Master ranking 2013; Elsevier 'Beste Studies' ranking 2012; Financial Times Global Masters in Management ranking 2012

Maastricht University is the best specialist university in the Netherlands (Elsevier)

Visit us and find out why we are the best!
Master's Open Day: 22 February 2014

www.mastersopenday.nl

Power Lines

Transmission lines

Transmission lines are usually on lattice towers and in the UK operate at a voltage of 110 kV, 230 kV or 400 kV three phase. Insulators are nearly always pendant type (ie string insulators). Power lines at these voltages are usually double circuit (ie two independent three phase systems, a total of six power lines and one earth wire).

High Tension Distribution Lines

HT Distribution lines are usually on poles which can be lattice galvanized steel, tubular steel, creosoted wood or reinforced concrete. In the UK, high tension distribution lines operate typically at 11 kV, 33 kV or 66 kV. Lower voltages of 3.3 kV or 6.6 kV have been used but these have no advantage over 11 kV and the power loss is higher.



At voltages up to about 11 kV, line insulators are usually pin type. Above about 11 kV, the insulators are usually suspension type. At the end of the lines and at section poles suspension insulators are used to apply the tension. Section poles and angle poles (where the line deviates from a straight line) are often stronger than intermediate poles. The section and angle poles usually have stay wires to a ground anchor so that the pole can withstand a horizontal force at the top of the pole.

Power line conductors are traditionally hard drawn copper but higher voltage lines now usually use aluminium conductors round a steel central core.

Power lines often have a steel earth wire which is usually above the power lines. This to some extent shields the power line from lightning strikes and prevents a pole becoming “live” in the event of an insulator failure. An earth wire has other advantages but is by no means universal.

Surge diverters

When a power line is struck by lightning, transformers or other equipment connected to the line can be damaged. The risk is reduced by “arcing horns” to provide a spark gap across every insulator and surge diverters at the ends of the line.

Surge diverters (Metrosil or equivalent) are non-linear resistors connected between the lines and earth through a spark gap. The non-linear resistors have a high resistance at low current but the resistance falls by orders of magnitude when the voltage exceeds the rated voltage. A lightning strike is thus short circuited to earth. After the lightning strike, the current falls to a value that should extinguish the arc at the spark gap. The surge diverter will save the switchgear and transformers but may be destroyed by the lightning strike. Doubling the voltage across a surge diverter typically increases the current by a factor of twenty.

Impedance and capacitance

The impedance of power lines is relatively high compared to cables as the self inductance is proportional to $\ln(d/r)$. Capacitance however is inversely proportional to $\ln(d/r)$ so the capacitance is relatively low compared to cables. Power lines often have a high proportion of steel in their cross section so have a relatively high resistance. Furthermore power lines can have a lower cross section than cables due to the greater cooling of the bare wire in air.

High Tension Underground cables

HT cables are now usually cross linked poly-ethylene (XPLE). These replace the traditional paper insulated cables (PILCSWA&S) ie paper insulated, lead covered, steel wire or steel tape armoured and served.

Buried cable joints are enclosed in a metal box in two halves. When the cable cores have been soldered together and insulated with tape, the box halves are united and filled with epoxy resin, or in the case of paper cables, filled with bitumen. XPLE cable joints in air are made watertight by heat shrunk plastic covers. It is prudent to keep a record of the exact location of buried joints.

Cable cores are traditionally copper but aluminium is sometimes used.

Medium Voltage lines and cables

MV cables in the UK operate at about 420 volts three phase four wire or about 240 volt single phase two wire. MV overhead lines are now only used for low cost supplies in rural areas, cables being more normal in urban areas.

MV cables are now usually PVC SWAPVC (ie pvc insulated, steel wire armored and pvc sheathed). Conductors are copper or aluminium. Copper is easier to solder and terminate but aluminium is cheaper.

Large sizes of three or four core cables are difficult to install. A popular arrangement for high current applications is ten single core cables, three each phase and one for the neutral. A single core cable induces a magnetic field. Single core cables therefore can be sheathed in lead but cannot have a magnetic armouring. They are often laid in trefoil, ie in groups of three, one each phase, strapped together to withstand the bursting force of the current. Any magnetic material near a single core cable can be subject to induction heating. Particular care is needed where single core cables pass through a steel bulkhead. If three cables on the same phase pass through a steel bulkhead in line then the impedance of the centre cable is less than the impedance of the cables at each end due to eddy current loss. Thus the middle cable will carry most of the load.

Single core PVC cables to cathodic protection ground beds do not last. The chlorine released at the ground bed destroys the PVC. High density polyethylene cables resist the chlorine.

Neutral Earthing

Power System Earth connection

The neutral point of generators and transformer secondaries is connected to earth to hold the voltage of each phase constant relative to earth. Failure to do so can result in dangerously high voltages building up relative to earth. All cables on the system have capacitance to earth so an earth fault anywhere on an unearthed AC system will result in current flowing through the fault which may be too small to be detected by the protection system while being large enough to be fatal to humans or animals.

To avoid third harmonic currents circulating between generators, it is usual to earth only one of the neutrals of high voltage generators running in parallel;. This is usually done through an earthing resistor to limit the earth fault current to full load. Earthing only one generator neutral can cause problems if there is an earth fault on the system that is cleared at the generator. It leaves the other generators feeding the fault by capacitive current.

Some power stations operate with a reactance in the neutral of each set. However this can resonate with the system capacitance at third harmonic frequency. The problem can suddenly appear when a new feeder is added to the system. If the reactor is iron cored then it can resonate at high current but not at low current. In such cases, the system can be unstable and resonate suddenly without warning. If this happens, there will be a loud 150 hz buzz on all the telephones.

The problem is solved if each generator has a unit transformer, ie each generator is directly connected to a delta/star transformer with the generator switching done on the secondary of the unit transformer. Each generator can have its own neutral connection that is separate from the other generators. The generator third harmonic voltage appears at each end of the transformer delta winding. There is no third harmonic current in the transformer primary so there is no third harmonic voltage on the transformer secondary. The transformer secondaries can all be connected to the same neutral point, either with or without a neutral earthing resistor.

Earth Electrodes

The earth electrodes for a power station or substation are typically steel or copper pipes set vertically in the ground and extending down to the water table. The earth points are usually in pairs with links so that either can be disconnected and tested without disconnecting the station earth. In arid areas, water well drilling equipment may be used to drill and case a pipe down to the water table for use as an earthing electrode.

For safety reasons, the conductors in multicore cables are enclosed in earthed steel armouring. High current single core AC cables may be unarmoured to avoid a magnetic path round the conductor but in that case will have an earthed non-magnetic conducting sheath. Such cables are usually laid in trefoil ie in groups of three cables, one cable of each phase. The cables are clamped together and the clamps must be strong enough to withstand the forces between the cables in the event of a through fault. The armouring or sheath provides a relatively low impedance connection back to the system neutral.

Power lines often but not always have a separate earth wire above the conductors. This provides a path for earth faults back to the system earth and prevents a pole becoming live. It also provides a measure of protection against a lightning strike, although a lightning strike is likely to break the earth wire while saving more expensive equipment.

Earthing Resistors

Single phase to earth fault currents can exceed the value of any other fault. Therefore to limit the damage done during a fault, a resistor is often installed between the neutral point of high voltage generators and transformers and the system earth. Earthing resistors are usually cast iron in an earthed metal vented enclosure similar to starting resistors for DC motors. Earthing resistors are usually sized to limit the earth fault current to the full load of one generator or transformer. In such an event, the voltage to earth of the faulty phase falls to zero while the other phases rise to line voltage to earth. Earthing resistors are usually rated to carry the full current for 30 seconds only. Protection must be fitted to switch off the faulty circuit within this period.

Neutral earthing of medium voltage power stations

A problem arises with the neutral earthing of medium voltage power stations. If the neutrals of all running generators are earthed, large third harmonic currents will circulate between the generators. The third harmonic voltages on all three phases are in phase. Any difference in the voltage between two generators results in a current of three times the phase current through the neutral. When a set is first synchronized, the emf is much lower on the incoming set than the emf on the running sets. The third harmonic current can prevent the set being synchronized unless the neutral isolator on the incoming set is open until the set is loaded up. This complicates the operating procedure and there is always the risk that the third harmonic current on running sets could overload the sets.

The problem is overcome in some power stations by only earthing one generator neutral, but this risks the much higher danger of losing the neutral connection for the system if this generator trips. In such an event, a consumer's voltage could suddenly rise without warning from 240 volts to 400 volts.

A better arrangement is to have dedicated earthing transformers solidly connected to each section of the busbars. The transformer winding is connected in star and the star point solidly connected to the neutral busbar and to the power station earth. The transformer also has a delta winding. Current circulating through this winding allows a single phase to earth current to flow in the star connected primary winding.

Earthing connections

Earthing connections within a power station or substation are usually made by copper strip with joints riveted and soldered. Generators, transformers and large motors have their metal enclosures connected by copper strip to the station earth. In hazardous areas, the earthing connections may be made by single core insulated cable to prevent the risk of sparking across to adjacent plant.

Switchgear

Breaking a high power electric current

When the contacts of a switch open, due to the inductance in the circuit, an arc occurs as the current continues to flow. The arc ionises the air and ionised air is a conductor. Thus as the contacts move further apart, the arc is drawn longer and longer causing intense heating. The contacts are quickly destroyed unless there is some mechanism to extinguish the arc. The MVA rupturing capacity of a switchboard is the maximum current that it can safely interrupt expressed in MVA as a three phase current at the rated voltage.

Air break switchgear

A typical method of extinguishing the arc is the use of an arc chute. The contacts are fitted with horns above the main contacts. The horns are situated in a heat resistant box open at the top and bottom. The heat from the arc causes the air to rise. This draws the arc up along the horns and into the heat resistant box and draws in air that has not been ionized. This box is fitted with vertical partitions greatly extending the path of the arc and ultimately extinguishing it.

Oil break switchgear

The contacts in oil break switchgear are enclosed in a tank filled with oil. The contacts are enclosed in a heat resistant box with passages such that as the oil vaporises the passages direct a blast of oil across the contacts which extinguishes the arc.



> Apply now

REDEFINE YOUR FUTURE
**AXA GLOBAL GRADUATE
PROGRAM 2014**

redefining / standards 

agence cdg © Photonistop

Air blast switchgear

The interrupter in air blast switchgear consists of a ball in contact with the end of a tube. When the switch opens, the tube is connected to an air receiver at high pressure. As the ball leaves the end of the tube, the high pressure air is released causing a blast across the contacts of air that is not ionised. This interrupts the current long enough for a separate off load isolator to open. Air blast switchgear is particularly suited to outdoor installations.

Vacuum Breakers

The contacts are in a vacuum. There is therefore no air to ionise.

SF6 switchgear

The contacts are in Sulphur Hexafluoride, SF₆.

Closing and tripping mechanism

Air break and oil break switchgear is usually closed by a powerful solenoid. The closing mechanism contains a strut in compression with a knee which can collapse. Normally the knee is “over centre”, the strut remains straight and operates in compression. When the circuit breaker is closed, it latches mechanically through this strut. A separate trip coil bends the knee. If the trip coil is energised, the knee bends releasing the circuit breaker. The circuit breaker trips whether or not the closing solenoid is energised.

Busbars

Circuit breakers connect the circuit to the busbars. The busbars are heavy section copper strips extending the full length of the switchboard. There is one busbar for each phase and for 4 pole circuit breakers a fourth busbar for the neutral. The switchboard is often in two or more sections with a circuit breaker between each section connecting the busbars. Major switchboards often have duplicate busbars ie a main and a standby busbar for each circuit breaker. In this case a further circuit breaker is required in each section to parallel the busbars. Each circuit breaker then has an off load isolator to select the busbar. This isolator is “make before break” and must be interlocked by a foolproof interlock so that it can only be operated when the appropriate busbar connecting circuit breaker is closed. Overriding this interlock would cause an explosion.

Plugging type switchboards

Major switchboards are plugging type. Each circuit breaker is plugged into the busbars and circuit. There are two common types, vertical and horizontal plugging. Vertical plugging circuit breakers are on wheels, ie truck type. These are pushed into the switchboard under the busbar and circuit “spouts”. The circuit breaker is then jacked up along guides and plugged into the busbar and circuit chamber spouts.

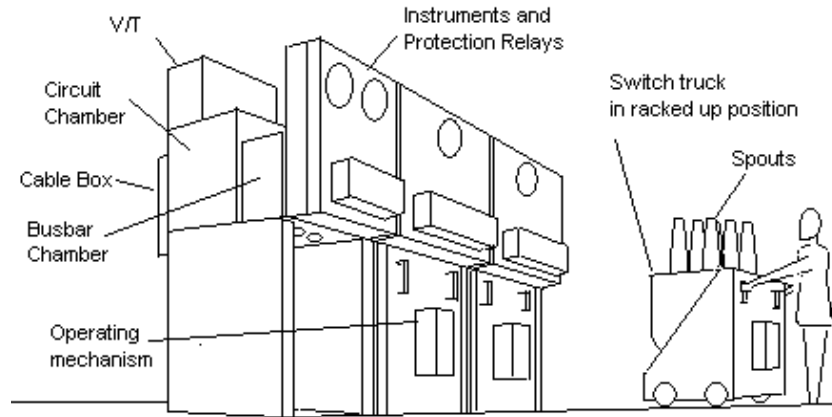

Vertical Plugging, metalclad oil break switchboard

When maintenance work is to be done on the circuit, the circuit breaker is lowered and removed and locks fitted to shutters that close over the busbar and circuit spouts and preventing the circuit breaker being plugged in. The shutter locks play an essential part in the permit to work system.

Horizontal plugging switchgear is racked in or out by a ratchet lever with the circuit breaker running on rails. Again there is provision for locks to be fitted to the busbar and circuit shutters.

Contactors

Medium volt motors are usually switched by contactors. These differ from switchgear in that the contactor is held closed by the contactor coil. If the supply fails, the contactor opens. This is unlike switchgear which latches closed and remains firmly closed until opened by the trip coil. Contactors suffer if the supply voltage falls below a minimum value as the contactor may partially open at the very time that the motor takes a higher current. This can destroy the contacts or in some cases weld them closed.

Instrument Transformers

Current Transformer (or CT)

It is inconvenient to connect Ammeters directly in high voltage high current circuits.

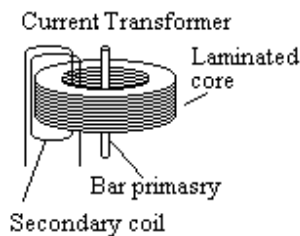

Instead a Current Transformer is installed in the circuit. These usually have a single bar of copper as the Primary winding. The secondary is wound so that at the design rating, the secondary ampere turns almost exactly match the primary ampere turns in both magnitude and phase angle. The net magnetising force is small.

The secondary is usually wound for 5 amps at the rated full load but may be other values (eg 1 amp).

The CT is a relatively small device perhaps a 6 inch cube and weighs a few pounds. In metal clad switchgear, they are installed in the CT chamber, a metal box at ground potential through which the high voltage conductors pass.

If the secondary is open circuited while the primary is on load, the full primary current becomes the magnetising current. This can cause a lethal voltage exceeding 1000 volts on the secondary and can permanently damage the current transformer.

Voltage Transformers (or VT or PT)

Voltage (or Potential) Transformers are connected directly to the high voltage circuit. The VT primary winding is connected across the full circuit voltage. It is usually metal clad with spouts or bushings to connect to the high voltage conductors. The secondary low voltage connection is by plug and socket. The VT can weigh anything from 50 kg to several tons, and its removal from the switchgear usually requires a crane.



BI

Business

Strategic Marketing Management

International Business

Leadership & Organisational Psychology

Shipping Management

Financial Economics

BI NORWEGIAN BUSINESS SCHOOL

EFMD EQUIS ACCREDITED

Empowering People. Improving Business.

BI Norwegian Business School is one of Europe's largest business schools welcoming more than 20,000 students. Our programmes provide a stimulating and multi-cultural learning environment with an international outlook ultimately providing students with professional skills to meet the increasing needs of businesses.

BI offers four different two-year, full-time Master of Science (MSc) programmes that are taught entirely in English and have been designed to provide professional skills to meet the increasing need of businesses. The MSc programmes provide a stimulating and multi-cultural learning environment to give you the best platform to launch into your career.

- MSc in Business
- MSc in Financial Economics
- MSc in Strategic Marketing Management
- MSc in Leadership and Organisational Psychology

www.bi.edu/master



The primary of a VT can be connected to the three phases in star or in delta. The secondary is also in star or delta to match the primary. However one of the secondary phases, usually the yellow phase, is earthed. The red and blue phases of the secondary are usually at 110 volts to earth at full design primary volts. Thus the secondary red to earth is proportional to the red to yellow primary volts in both magnitude and direction. Similarly the secondary blue to earth volts is proportional to the primary blue to yellow volts in magnitude and direction. Similarly, the secondary red to blue volts is proportional to the primary red to blue volts in magnitude and direction.

Some installations use an “open delta” secondary connection. Here the red to blue winding of the secondary is not connected to the other windings. The three connections to the red-yellow and yellow-blue windings are connected to the red, earth and blue circuits in the normal way, but the red-blue winding is connected to two more secondary terminals allowing this winding to be used for a separated designated purpose, eg a generator automatic voltage regulator.

Control And Indication

Circuit breaker close and trip circuits

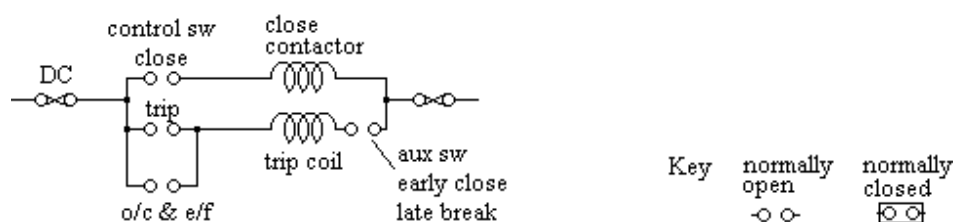

Circuit Breakers are usually closed by a solenoid operated by a contactor and tripped directly by a trip coil. The trip coil and closing contactor operate on DC from a battery but the solenoid may operate on DC from a battery, or on AC or rectified AC. Alternatively, the closing mechanism may be operated by a precharged powerful spring that is released by the closing contactor.

During closing, the auxiliary switch in the trip circuit closes before the main contacts make. During tripping, the auxiliary switch in the tripping circuit opens after the main contacts have opened.

The circuit breaker must not close unless the trip fuses are intact so the closing contactor circuit is always routed through the trip fuses. There is a slight danger that the closing contactor may be faulty allowing the circuit breaker to close but blowing the trip fuses. Some manufacturers therefore have trip fuses rated about 15 amps and additional 4 amp fuses for the closing contactor supplied through the trip fuses.

Circuit breaker indication circuits

The circuit breaker usually has green, red and amber indicator lamps to show if the circuit breaker is open, closed or has tripped on fault.

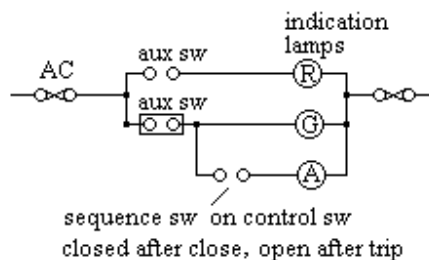

Current Transformer circuits

The over current and earth fault protection relays and the ammeter are supplied from current transformers on the main circuit conductors. The CT secondary current is proportional to and in phase with the CT primary current.

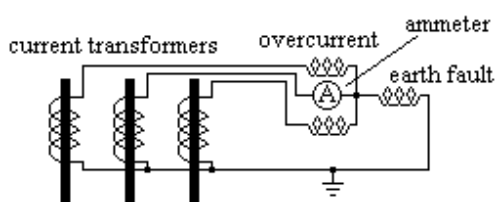

Voltage Transformer circuits

Voltage transformers are usually fitted to incoming circuit breakers. They can be star connected.

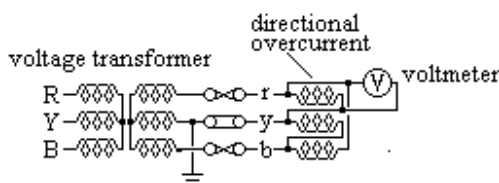

Or they can be delta connected.

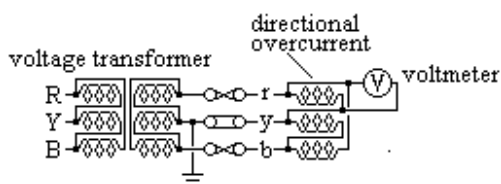

With either connection, the secondary r – y and r – b voltages are proportional to and in phase with the primary R – Y and B – Y voltages.

Incoming circuit breakers usually have a voltage transformer connected to a voltmeter and the voltage coils of a directional over current relay.

When fitted, a kilowatt meter, a reactive kVA (ie kVAR) meter, a kilowatthour meter, a power factor indicator and a frequency meter each require a supply from the voltage transformer.

A directional earth fault relay requires a special voltage transformer.

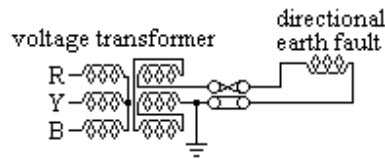

The primary is star connected in the normal way but the secondary winding is connected in open delta. Under normal conditions, there is no output voltage on the open ends of this winding. Under fault conditions, one or more of the primary voltages is reduced giving a voltage on the open delta winding. The phase relation of this voltage depends on the phase or phases suffering the fault as does the phase relation of the fault current.

Alternator circuit breaker circuits

The alternator circuit breaker must not be closed unless (i) the voltage is the same as the system voltage and (ii) the frequency is the same as the system frequency and (iii) the voltage is in phase with the system voltage.

Condition (i) above is met by adjacent voltmeters showing the two voltages. Conditions (ii) and (iii) are met by a synchroscope.

Need help with your dissertation?

Get in-depth feedback & advice from experts in your topic area. Find out what you can do to improve the quality of your dissertation!

Get Help Now

Go to www.helpmyassignment.co.uk for more info



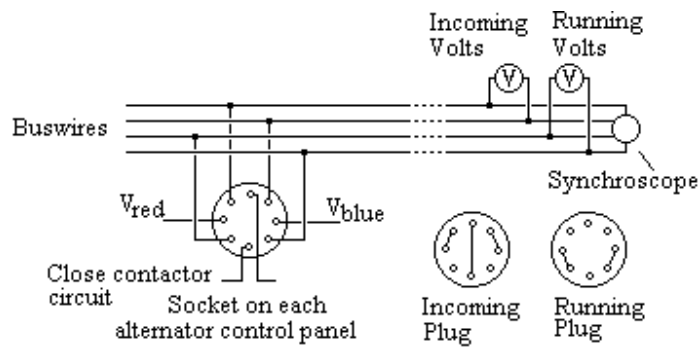

The diagram shows a well tried system for manually synchronising the sets. The Running Plug is kept in the socket of a set on load and the Incoming Plug is put in the socket of the incoming set before it is synchronised.

Sometimes an automatic synchronising system is provided.

System Time

Two clocks are required, one digital and one electric. The frequency of the system is constantly adjusted to keep the synchronous time in step with the digital time

HT Motor under voltage protection

Voltage Transformers on busbars are not favoured because of the risk of a fault on the spouts. However, the under voltage can take the voltage supply from the incomer VTs provided it is routed through the circuit breaker auxiliary switches.

The diagram shows a typical arrangement.

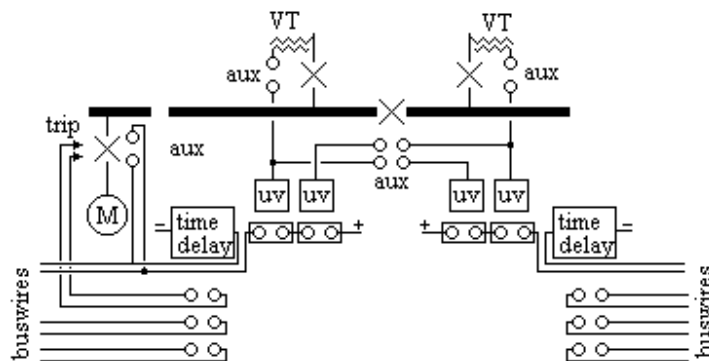

Contactor circuit

A three phase contactor is usually connected between two phases, ie the coil operates at phase voltage.

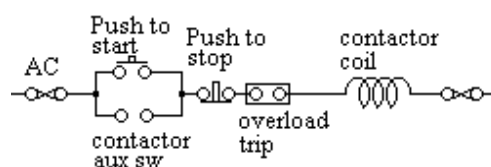

When the start button is pressed, the contactor closes and remains closed through an auxiliary contact on the contactor.

The contactor is opened either by the stop button or by any normally closed contact in series. The overload is usually thermal (eg bi-metal strips heated by the load current, often with single phase protection). Sometimes there are additional trips (eg earth fault protection). If there is no single phase protection, then a blown fuse may result in the motor burning out.

In the event of power failure, the contactor opens. When power is resumed, the contactor remains open until manually restarted.

When the contactor closes, there is initially a large current through the coil limited mainly by the coil resistance. This gives a strong closing force. When the contactor is closed, the air gap in the magnetic circuit is reduced, the self inductance of the coil is increased and the coil current is reduced to an economical level.



Brain power

By 2020, wind could provide one-tenth of our planet's electricity needs. Already today, SKF's innovative know-how is crucial to running a large proportion of the world's wind turbines.

Up to 25 % of the generating costs relate to maintenance. These can be reduced dramatically thanks to our systems for on-line condition monitoring and automatic lubrication. We help make it more economical to create cleaner, cheaper energy out of thin air.

By sharing our experience, expertise, and creativity, industries can boost performance beyond expectations. Therefore we need the best employees who can meet this challenge!

The Power of Knowledge Engineering

Plug into The Power of Knowledge Engineering.
Visit us at www.skf.com/knowledge

SKF



Instruments

Moving Coil Meters

Moving coil instruments measure DC volts and amps or rectified AC volts or amps. They are accurate but are moderately expensive. The scale is linear.

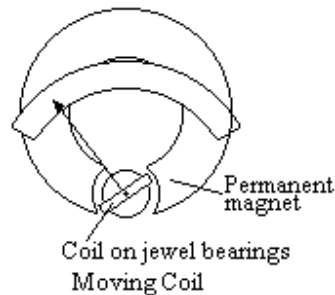

The moving coil is mounted on needle point bearings. It swings between the poles of a permanent magnet and round a cylindrical soft iron core.

The connections to the coil are through spiral springs at the front and back of the spindle which also provide the restraining torque.

The coil is wound with fine wire to give full scale deflection (fsd) with a current which is typically between $50\ \mu\text{A}$ and 1mA and at a voltage typically 75mV .

When used as a voltmeter, it is connected in series with a high resistance.

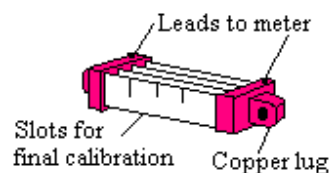

When used as an ammeter to measure a high DC current, a shunt resistor is connected in the circuit and the meter measures the voltage across the shunt. The connections to the meter are on the shunt between the main connections.

A moving coil meter can be used to measure AC volts or amps when connected to a rectifier, usually a full wave rectifier. The meter measures the average value for a half wave (0.636 of peak value) but is calibrated to display the rms value (0.707 of the peak value). Thus different resistances are needed for readings of DC and AC. The AC reading depends on the form factor of the wave and to some extent on the frequency

A moving coil instrument cannot be used to measure watts.

Moving iron meters

Moving iron instruments contain a fixed and a moving iron element in a fixed coil. The moving iron is restrained by a spring.

Current in the coil magnetises both iron elements similarly and they repel each other.

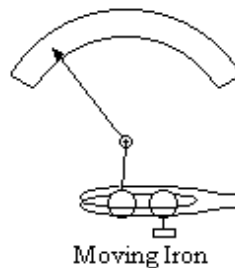

Moving iron instruments measure DC or AC volts and amps. When calibrated on DC, the meter will read the rms value of low frequency. AC current but due to the inductance of the coil should be calibrated on AC for reading AC volts. The deflection is approximately proportional to the square of the current. On AC the reading depends on the frequency but is not so dependant on form factor.

Moving iron instruments are cheap but not very accurate, typically 5%. Errors arise due to residual magnetism in the moving iron or stray magnetic fields.

Solenoid type moving iron meter

If the coil is a solenoid pulling the moving iron against a spring, without a fixed iron element, the deflection is more linear. The moving iron can be shaped to give any desired response.

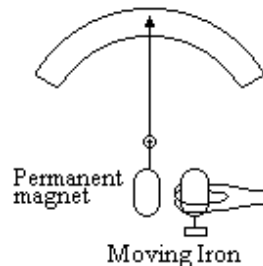
Permanent magnet moving iron meter

If the moving iron is a permanent magnet outside the coil, and the coil has a fixed iron core, then the moving iron meter is proportional to the current in the coil and the pointer deflection shows the direction of the current.

Dynamometer instruments

Dynamometer instruments are used for high accuracy measurement of DC or AC volts, amps or watts. The instrument has a fixed coil and a moving coil suspended on a filament. The fixed coil is often in two parts each side of the moving coil. It is intended for laboratory use but can be used with care in the field. Laboratory “sub-standard” voltmeters, ammeters and wattmeters are usually dynamometer type. The moving coil of a dynamometer ammeter is shunted by a low resistance.

For DC or AC voltage measurements, both the fixed and the moving coil are connected in series and in series with a resistance. For accurate measurements of AC volts, the instrument should be calibrated on AC at the same frequency.

For DC or AC current measurements, both coils are connected in series and the instrument measures the volt drop across a shunt. For use on AC, the instrument should be calibrated at the same frequency.

A dynamometer instrument can be used to measure watts. One coil is connected through a series resistance to the voltage and the other coil is connected to a shunt or current transformer in the current circuit. For accurate AC measurements, the instrument should be calibrated on AC at the same frequency. However the self inductance of the coil means that the current in the voltage coil is not in phase with the voltage. There is therefore an unavoidable error in the phase angle between the current in the voltage coil and the current in the current coil unless the instrument has been calibrated at the same power factor.

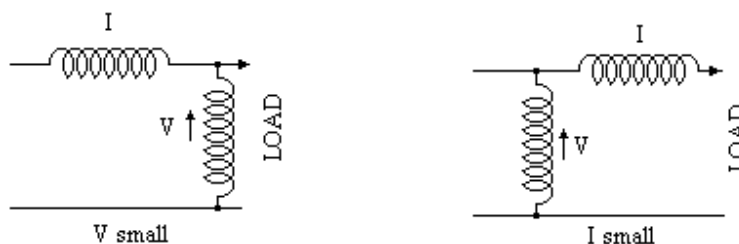

When used as a wattmeter, the voltage connection can be upstream or downstream of the current coil. If V is small and I is large, the voltage connection should be nearest to the load so that the voltage does not include the drop across the current coil. Conversely, if the voltage is large and the current is low, connect the voltage upstream of the current coil so that the current coil does not include the current in the voltage coil.

A 1st grade voltmeter has an accuracy of 1% of fsd, ammeter 1½ % and a wattmeter 2½%

Hot wire instruments

Hot wire can measure DC or AC with no frequency or wave form error but have a low overload capacity. They are cheap and not very accurate.

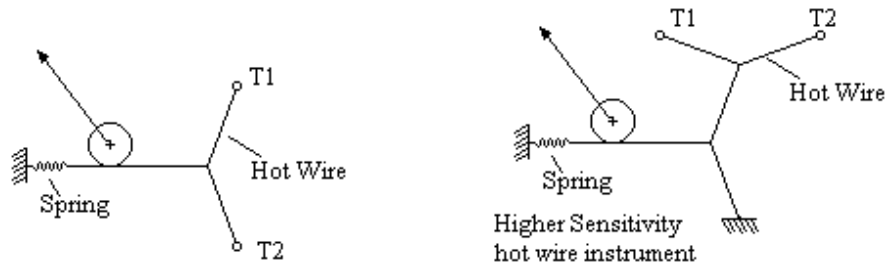

A hot wire instrument contains a resistance wire that is heated by the current. The expansion of the wire is used to deflect the pointer. The long term accuracy is poor and the instrument is easily damaged by overload. There is a delay in the reading as the wire heats up.

However the instrument can be calibrated on DC and will then read correctly on AC at any frequency or form factor provided the self inductance is negligible.

Electrostatic Voltmeter

High voltages can be measured by the electrostatic force between two plates. In the simplest form, the force can be measured by a balance but this is hardly practicable outside a laboratory.

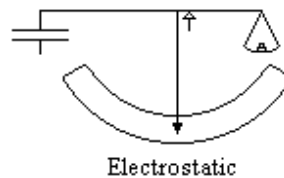

Practical electrostatic voltmeters have a fixed and a moving vane that overlap. The moving vane is restrained by a spring.

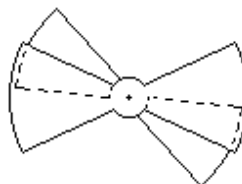

When a high voltage, typically tens of kV, is applied between the vanes, they try to increase the overlap.

The voltmeter for a high voltage test set is often electrostatic. On a 0 to 1000 volt scale, the markings will not be shown below 500 volt due to insensitivity at low deflections. Electrostatic meters take no current on DC.

DC Ampere Hour or Coulomb meter

DC quantity of electricity can be measured by electrolysis. A typical meter is shown. A glass container is filled with mercury and a liquid mercury salt solution. When current flows, mercury is transferred to the hopper in proportion to the ampere hours. When the tube fills, it siphons out so the quantity in the base is an integral number of the volume in the U tube.

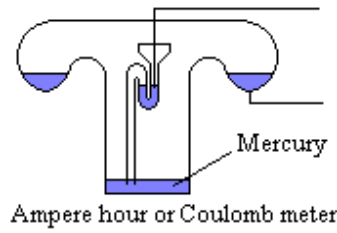

Tilt the meter to reset.

Induction meter

Consider a cylindrical drum of thin metal which is subjected to two AC fluxes Φ_1 and Φ_2 both in the same phase. These induce currents I_1 and I_2 in the drum. By Lenz's law, these oppose the ampere turns of the magnetising forces. But due to leakage flux the currents lag the fluxes that induce them.

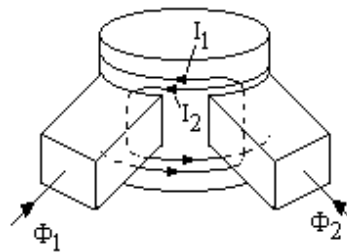

“I studied English for 16 years but...
...I finally learned to speak it in just six lessons”
Jane, Chinese architect

ENGLISH OUT THERE

Click to hear me talking before and after my unique course download



It can be seen that Φ_1 and I_2 exert an anti-clockwise torque on the drum while Φ_2 and Φ_1 exert a clockwise torque. The drum does not rotate when Φ_1 and Φ_2 are in phase.

The torque due to I_1 is proportional to $I_{1\text{ rms}} \Phi_{2\text{ rms}} \cos \alpha$ where α is the phase angle between I_1 and Φ_2 due to the leakage flux.

Consider now if Φ_1 and Φ_2 are not in phase. Let Φ_1 lead Φ_2 by β .

The torques are proportional to

$$\Phi_{1\text{ rms}} I_{2\text{ rms}} \cos (\alpha + \beta)$$

and $\Phi_{2\text{ rms}} I_{1\text{ rms}} \cos (\beta - \alpha)$ and are no longer equal.

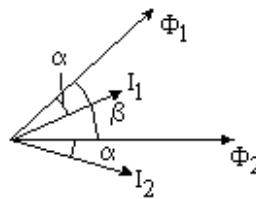

The magnetising forces exert a torque on the drum proportional to

$$\Phi_{2\text{ rms}} I_{1\text{ rms}} \cos (\beta - \alpha) - \Phi_{1\text{ rms}} I_{2\text{ rms}} \cos (\alpha + \beta)$$

If $\Phi_{1\text{ rms}} = \Phi_{2\text{ rms}}$ then $I_{1\text{ rms}} = I_{2\text{ rms}}$ and

$$\text{Torque} = K \Phi_{\text{rms}} I_{\text{rms}} [\cos (\beta - \alpha) - \cos (\alpha + \beta)]$$

$$= K \Phi_{\text{rms}} I_{\text{rms}} \sin \alpha \sin \beta$$

Disc Induction Meter

If the drum is rolled out flat, it becomes a disc. The disc will rotate if subjected to the interlinking flux of two coils carrying AC currents which are not in phase.

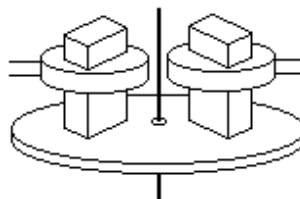

The two coils can be supplied from the same source if one is supplied through a resistance or capacitance. Alternatively, one of the poles could be a “shaded pole”, ie be fitted with a thick copper band.

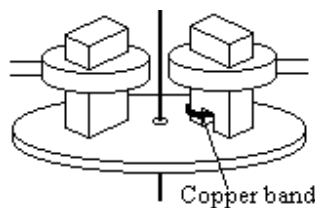

Watt Hour Induction Meter

The Watt Hour meter has one coil connected to the voltage and the current in this coil lags the voltage by 90° . The other coil is connected to carry the current.

Thus $\beta = 90^\circ - \phi$ and $\sin \beta = \cos \phi$

The torque is proportional to $V I \cos \phi = \text{watts}$

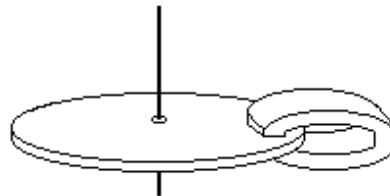

A permanent magnet is fitted round the disc. This causes an eddy current loss proportional to $(\text{speed})^2$.

This loss exerts a braking torque

The braking torque \times speed = loss

braking torque = $K (\text{speed})^2 / (\text{speed})$
 $= K \text{ speed}$.

But the driving torque = braking torque

Thus speed is proportional to watts

Hence the number of rotations is proportional to watt hours

Example

An induction meter has a copper disc. The disc is changed to an aluminium disc of the same size. The speed is to be increased by 50% for the same torque. Find the change in restraining magnet strength. Specific resistance of aluminium = 1.7 \times specific resistance of copper

Eddy current loss is $\propto n^2 B_{\max}^2 t^2 / \rho$

Torque = power/speed $\propto n B_{\max}^2 t^2 / \rho$

With suffix 2 for new value and suffix 1 for old

$n_1 B_{\max 1}^2 t_1^2 / \rho_1 = n_2 B_{\max 2}^2 t_2^2 / \rho_2$

$B_{\max 2} / B_{\max 1} = (t_1/t_2) \sqrt{[(n_1/n_2) (\rho_2/\rho_1)]} = \sqrt{[(1/1.5) (1.7/1)]} = 1.06$

B must be increased by 6%

Fluxmeter

A DC fluxmeter is a moving coil meter without a spring connected to a search coil. When the flux through the coil is changed, a current flows through the meter which is restrained only by its own back emf e.

Meter coil has n turns, area A, flux density B and carries a current i

Search coil has N turns and the flux is Φ , circuit resistance R and inductance L

Torque on meter coil $T = i n A B$

Back emf $e = n A B d\theta / dt$ where θ is the deflection.

Let moment of inertia of meter coil be J

$$T = J \frac{d^2\theta}{dt^2} = J \frac{d\omega}{dt}$$

Eliminate T , $i n A B = J \frac{d\omega}{dt}$

$$\text{hence } i = (J/nAB) \frac{d\omega}{dt}$$

Emf in search coil = $N \frac{d\Phi}{dt} = L \frac{di}{dt} + R i + e$

Substitute for e and i

$$N \frac{d\Phi}{dt} - nAB \frac{d\theta}{dt} = L \frac{di}{dt} + (RJ/nAB) \frac{d\omega}{dt}$$

Integrate wrt t from 1 to 2

$$N (\Phi_2 - \Phi_1) - nAB (\theta_2 - \theta_1) = L (i_2 - i_1) + (RJ/nAB) (\omega_2 - \omega_1)$$

At start and finish, $i = 0$ and $\omega = 0$

$$\text{Thus } N (\Phi_2 - \Phi_1) - nAB (\theta_2 - \theta_1)$$

ie the deflection of the meter is proportional to the change in flux

Example

The voltage coil of a wattmeter has inductance 4 mH and is in series with a 2 k Ω resistance. The meter has been calibrated on DC.

The meter reads 50 watts at a load current of 1 amp at 160 volts and 1 kHz. Find the % error.

$$\text{Reactance of coil} = 2\pi fL = 25.13 \text{ ohms}$$

$$\text{Phase angle of current in voltage coil} = \arctan(25.13/2000) = 0.7199 \text{ degrees}$$

$$\cos \phi = W/(VI) = 50/(160 \cdot 1) \text{ therefore } \phi = 71.790 \text{ degrees}$$

$$\text{True watts} = 160 \cdot 1 \cdot \cos(71.790 + 0.720) = 48.09 \text{ Hence Error} = 4\%$$



What do you want to do?

No matter what you want out of your future career, an employer with a broad range of operations in a load of countries will always be the ticket. Working within the Volvo Group means more than 100,000 friends and colleagues in more than 185 countries all over the world. We offer graduates great career opportunities – check out the Career section at our web site www.volvogroup.com. We look forward to getting to know you!

VOLVO
AB Volvo (publ)
www.volvogroup.com

VOLVO TRUCKS | RENAULT TRUCKS | MACK TRUCKS | VOLVO BUSES | VOLVO CONSTRUCTION EQUIPMENT | VOLVO PENTA | VOLVO AERO | VOLVO IT
VOLVO FINANCIAL SERVICES | VOLVO 3P | VOLVO POWERTRAIN | VOLVO PARTS | VOLVO TECHNOLOGY | VOLVO LOGISTICS | BUSINESS AREA ASIA

Protection

Electrical Protection

Electrical Protection operates in conjunction with switchgear to automatically switch off faulty equipment. A fault on duplicate feeders is detected by the protection which trips the switches at both ends of the faulty equipment. The supply to consumers is not affected as the other feeder remains in service.

Over Current and Earth Fault

Over current and earth fault protection trips the switch if the current in any phase exceeds the design or if the current in any phase returns through earth. The earth fault current is detected by residual connection of the current transformers. Current in any phase that does not return through another phase or the neutral activates the protection. One method is to route all three phases and the neutral through one current transformer. The secondary then carries the vector sum of these currents.

Many three wire systems use a resistance in the neutral to limit the earth fault current to no more than full load. In this case sensitive earth fault protection is mandatory, usually operating if an earth fault of 10% full load is detected.

Over current and earth fault protection is usually time lagged so that the switches trip in sequence till the fault is cleared. The most common type is Inverse Definite Minimum Time Lagged (IDMTL O/C & E/F) protection. The relay is induction type and the angle of rotation gives the time lag. The time lag is inversely proportional to the current up to about 20 times the setting. Above this, the time lag is constant and typically can be set at any value between 0.1 and 2 seconds.

In many cases, time lagged over current and earth fault protection on its own is unsatisfactory. Switches closest to the power station trip last. Thus faults near the power station, which are the heaviest faults take longest to clear.

HRC Fuses

Medium Voltage Feeders are often protected only by High Rupturing Capacity Fuses. These clear the fault in a fraction of a cycle, before it has risen to its first peak value. Thus faults with a prospective high fault level can be safely cleared.

Instantaneous Over Current and earth fault protection

If the equipment has relatively high impedance (eg a transformer), then over current and earth fault protection, which is set to operate above the maximum through fault value, can be instantaneous.

Circulating Current Protection

This protection compares the current flowing into the protected equipment with the current leaving. If they are not the same, the protection operates.

Restricted Earth Fault Protection

Restricted Earth Fault protection is a form of circulating current protection. Current transformers are fitted to each phase and the neutral and the vector sum is measured. Any current leaving a phase that does not return through another phase or the neutral trips the protection. Restricted Earth Fault Protection only detects earth faults within the protected zone.

Distance Protection

This protection measures both current and voltage. The voltage divided by the current gives the impedance to the fault. The time lag of the protection is related to the impedance. If the impedance is low, the protection clears quickly. If the impedance is high, the time delay is longer. Thus switches nearest the fault clear the fault first.

Generator Protection

AC generators are usually provided with circulating current or restricted earth fault protection. Circulating current protection applied to each winding protects against all faults on the winding except inter turn faults on the same winding. This protection has current transformers in the neutral pit and in the main output circuit breaker. The protection operates if current entering a winding from the neutral does not leave through the main circuit breaker.

If the star point of the generator is within the windings, then circulating current protection must be of restricted earth fault type. Restricted earth fault protection does not protect against faults between windings. However inter turn faults and faults between windings will quickly develop into earth faults.

If the current transformers are not exactly balanced, a high value through fault may operate the circulating current protection incorrectly. To avoid this, some relays have a “bias” restraining coil of a few turns which carries the through current. Alternatively, a series resistance of the right value in the relay circuit can be used and the protection is then called Unbiased Circulating Current Protection.

Simple time lagged overcurrent protection is unsatisfactory for generators. Over current protection without voltage restraint may not operate due to the demagnetizing effect of a heavy low power factor current. The over current protection must be time lagged to allow feeders to clear the fault before the power station is shut down. By this time, the fault current may have fallen below the overload setting of a relay that does not have voltage restraint. Generators are therefore usually provided with voltage restrained time lagged overcurrent protection. At full voltage, the current setting is above full load, but at lower voltage, the current setting is lower.

Reverse power protection is often provided. If the generator prime mover shuts down, the generator may act as a motor and keep the machine rotating. Reverse power protection prevents this.

Negative Phase Sequence protection is sometimes provided for large generators. This operates if the currents in each phase are so different that the uneven heating in the generator will damage the generator.

Over and Under Voltage Protection is sometimes provided to shut down the machine if the AVR has become faulty causing the voltage to go out of range.

However this may not operate if several generators are running in parallel.

Cables and Power Lines

Cables and Distribution lines are usually provided with IDMT Over current and Earth Fault protection. Transmission lines use more sophisticated protection eg Distance Protection.

Circulating current protection can be applied to cables or power lines but then a pilot cable or carrier wave is needed to transmit the information to the far end for comparison. One pilot cable system converts the three phase current to a single phase voltage with different conversion factors for each phase. The protection system at each end compares the two voltages and trips the local circuit breaker if they are not the same. Transmission lines often use a high frequency carrier wave on the power line to transmit the information and also for telecommunication between the substations.

Directional overcurrent and earth fault protection is usually fitted at the receiving end of duplicate power lines or cables unless circulating current protection is fitted. This is to prevent a feed back to the fault. It is usually time lagged to trip before the overcurrent on the healthy feeder.

Transformer Protection

Instantaneous earth fault protection with a low current setting can be provided on the primary side of a delta/star transformer. An earth fault on the secondary side is seen by the primary as a phase to phase fault. Instantaneous over current protection can be fitted on the primary provided it is set at a current above the through fault value. The Protection should trip both the HV and LV circuit breakers

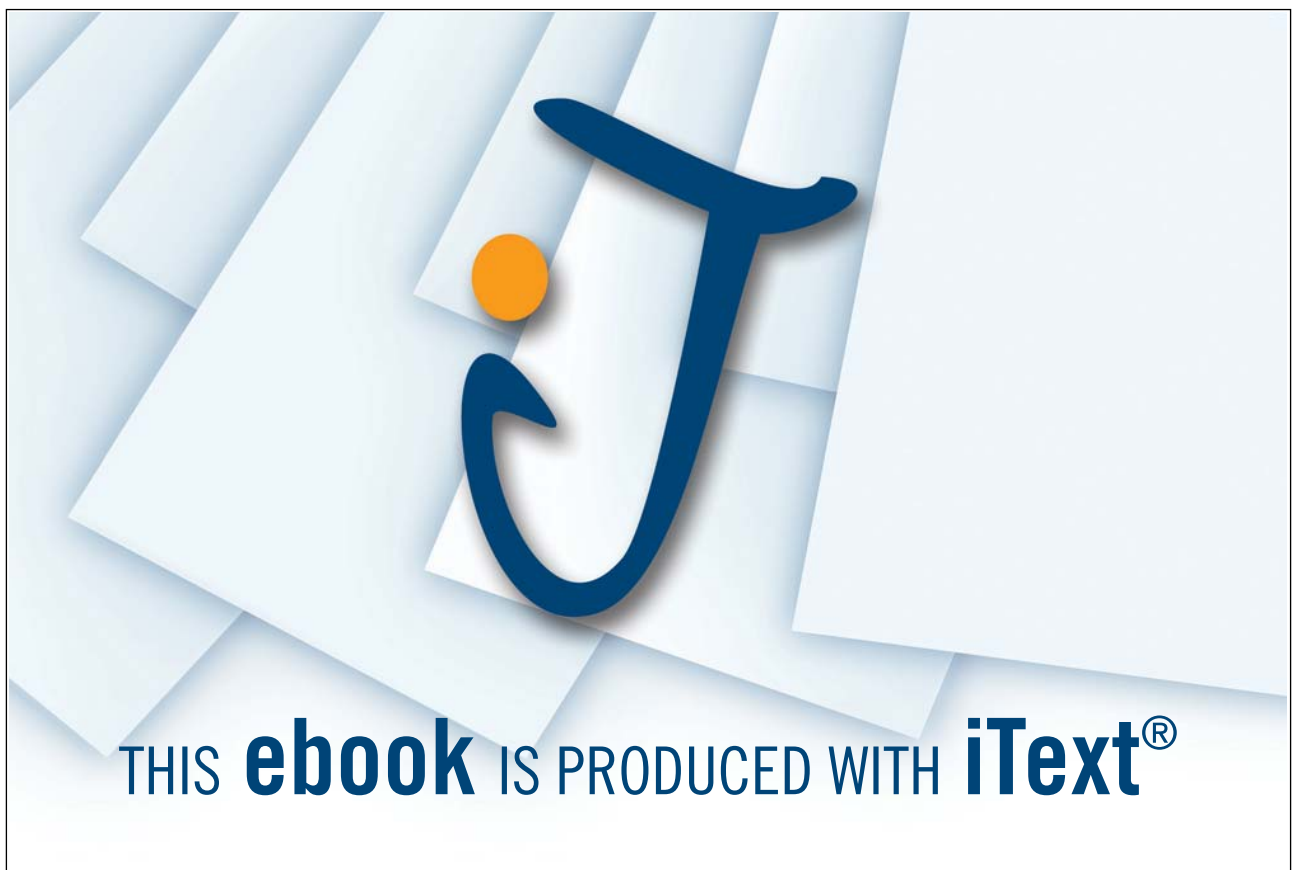

Time lagged over current protection is required on the primary to protect against overload and through faults that are not cleared elsewhere. This should be on all three phases. The traditional two over current and earth fault relay is unsatisfactory as phase to phase faults on the secondary of a delta/star transformer are seen as one high current and two lower currents on the primary. Thus fault clearance times would depend on which phases the fault occurs. A three phase overcurrent relay and a separate earth fault relay are preferable.

Directional overcurrent and earth fault protection is usually provided on the secondary side of duplicate transformers to prevent the secondary feeding back to a fault on the primary side. As this current may be nearly zero power factor, appropriate phase displacement of the voltage connection is needed.

The secondary windings of a transformer are usually protected by Restricted Earth Fault Protection. This protection operates if the vector sum of the three phases and the neutral on the secondary is above the setting, typically 10% full load. The setting is low to protect against faults near the star point.

Circulating current protection can be used with appropriate current transformer ratios. For a delta/star transformer, the CTs are connected in star on the primary and delta on the secondary. The protection must be time lagged to allow the magnetizing current to stabilize. The magnetizing current is seen as an in zone fault and this current can exceed full load current for several cycles when the transformer is switched on. Furthermore, many transformers have a tap changer to allow the turns ratio to be changed. The current setting of circulating current protection must be high enough to prevent spurious operation with an out of zone through fault on any tap setting.

Buchholtz Protection

Buchholtz Protection detects faults in oil filled transformers. It consists of a chamber in the oil pipe between the transformer and its expansion tank. It contains a float switch which sounds an alarm if air or vapour collects in the chamber. This is often an indication that there is a fault between turns in the winding or a fault between laminations in the core and provides early warning that maintenance is needed.

A separate trip switch is operated by a flap in the Buchholtz chamber. In the event of a more severe fault, there is a rush of oil or vapour through the Buchholtz chamber which operates this flap tripping the switches on the primary and secondary of the transformer.

Large transformers are often fitted with an oil temperature trip and a “hot spot” temperature trip. This is a temperature trip in the oil with a self contained heater carrying a current proportional to the load current.

Motor Protection

Overload Protection and Single Phase Protection is normally provided for large motors. The overload protection is usually thermal, ie operated by bi-metal strips. The single phase protection operates if the thermal response of each phase is not the same on all phases.

Instantaneous over current and earth fault protection is also usually provided. The instantaneous over current protection is set above the starting current value. Current can only exceed this value when there is a fault so operation can be instantaneous. The earth fault protection is usually set at about 10% full load. If the motor is star connected, a fault near the star point may not be detected until it has developed into a more serious fault.

Time delayed Under Voltage protection is usually provided for large motors. If the supply fails all motors stop. If the supply is then restored, all motors try to start simultaneously overloading the supply which will then trip again. Time lagged under voltage protection trips the motor when the supply fails and the motors can be started in sequence manually when power is restored.

Small motors are usually provided with thermal overload and single phasing protection. High Rupturing Capacity Fuses, HRC Fuses, give protection for short circuits. Small motors are usually supplied through contactors which trip in the event of a temporary power failure allowing them to be started in sequence.



www.sylvania.com

We do not reinvent
the wheel we reinvent
light.

Fascinating lighting offers an infinite spectrum of possibilities: Innovative technologies and new markets provide both opportunities and challenges. An environment in which your expertise is in high demand. Enjoy the supportive working atmosphere within our global group and benefit from international career paths. Implement sustainable ideas in close cooperation with other specialists and contribute to influencing our future. Come and join us in reinventing light every day.

Light is OSRAM

OSRAM
SYLVANIA 



Power Systems

Underlying philosophy

All essential supplies are through duplicate feeders. The protection is arranged to automatically isolate any faulty equipment from both the supply and from feedback through the duplicate (healthy) equipment.

Typical System

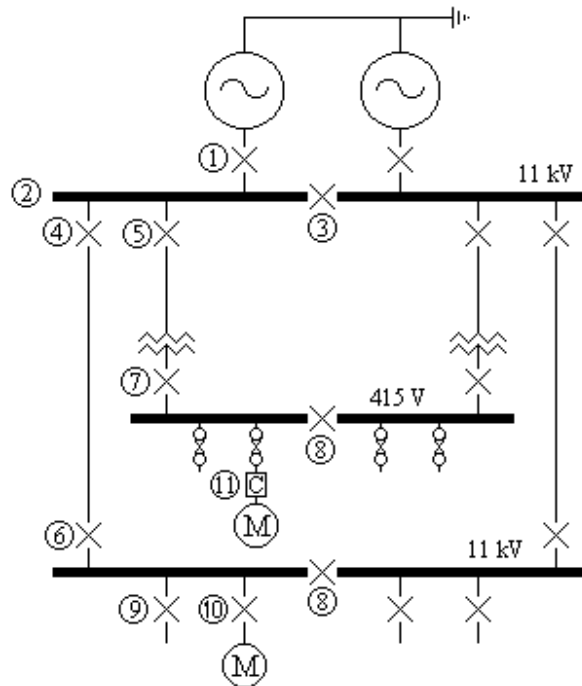

Protection, typical settings and typical instrumentation

- 1) Alternator
- Circulating Current or Restricted Earth Fault set at 10% full load. (If Star Point is made inside the generator then it must be Restricted E/F)
 - Voltage Restrained Over current set at 100% full load 1.3 sec
 - Earth Fault set at 10% 1.3 sec
 - Reverse Power
 - Negative Phase Sequence Protection if required

Typical instruments are ammeter(s), kW meter, kVAr meter, power factor indicator, field voltage and field current.

The incoming voltmeter, running voltmeter, incoming frequency meter, running frequency meter, system time clock, master time clock and synchroscope are on the synchronising panel

- 2) Busbars Circulating Current protection is sometimes fitted to each side of the power station busbars. The total net current flowing into each phase of the busbars is measured and if not nearly zero all circuit breakers on the bus section and the bus section circuit breaker are tripped after a short time lag.
- Provision is provided to switch off the protection to allow injection tests on any circuit breaker.
- 3) Bus Section Circuit Breaker
Over current and Earth Fault Protection set at 100% and 10% 0.9 sec. This is not required if there is busbar circulating current protection. Even without Circulating Current protection, it is often not fitted. Busbar faults are very rare and when they do occur, usually result in total shutdown of the generating station.
- 4) Feeder Over current and Earth Fault Protection set at 100% 0.5 sec
Typically the only instrument would be an ammeter unless kW or kWh are required in which case a VT will be needed.
- 5) Transformer Feeder
Over current, set at 100% 0.5 sec
High set instantaneous over current protection (set above the through fault level)
Earth Fault, 10% full load 0.1 sec
Circulating Current (eg Mag Balance) is sometimes fitted
Buchholtz protection
Inter tripping with LV circuit breaker
Typically the only instrument would be an ammeter.
- 6) Incomer Directional Overcurrent set at 50% 0.1 sec and Directional Earth Fault set at 10% 0.1 sec sensitive to lagging currents in reverse direction to normal.
Typically a voltmeter and ammeter would be fitted.
- 7) Transformer Incomer
Either Circulating Current protection or Restricted Earth Fault protection for the LV windings set at 10% 0.1 sec
- Directional Overcurrent set at 50% 0.1 sec and Directional Earth Fault set at 10% 0.1 sec sensitive to zero power factor lagging currents in reverse direction to normal.
Inter tripping with HV circuit breaker
Typically a voltmeter and ammeter would be provided.
- 8) Bus Section Over current and Earth Fault protection is sometimes fitted but serves little useful purpose. It could be time lagged with the feeders to isolate one side of the switchboard in event of a very rare busbar fault. However to get discrimination, the feeder time lags must be increased causing excessive delay in clearing the much more common feeder cable faults.

An ammeter is sometimes provided, but is rarely necessary.

9) Feeder Overcurrent protection set at 100% 0.1 sec and Earth Fault protection set at 10% 0.1 sec.

Typically, the only instrument would be an ammeter.

10) HV Motor feeder

High set instantaneous over current protection set above starting current level.

Instantaneous Earth Fault protection

Thermal overload set at 100% CMR (continuous maximum rating) of the motor.

Single phasing protection with thermal delay

Under voltage with time delay of 5 sec

Trips for mechanical reasons (eg bearing temp)

Trips for driven machine faults (eg pump low suction)

An ammeter is required both on the circuit breaker and on the remote stop/start station.

11) MV Motor feeder

Over current fault protection is provided by HRC Fuses.

The motor is controlled by a contactor with thermal overload and single phasing protection.

Earth Fault protection is often provided

Under voltage protection is inherent in the contactor.

Trips for mechanical reasons can be incorporated.

An ammeter is required both on the contactor and on the remote stop/start station.



CHALLENGING PERSPECTIVES

Internship opportunities

EADS unites a leading aircraft manufacturer, the world's largest helicopter supplier, a global leader in space programmes and a worldwide leader in global security solutions and systems to form Europe's largest defence and aerospace group. More than 140,000 people work at Airbus, Astrium, Cassidian and Eurocopter, in 90 locations globally, to deliver some of the industry's most exciting projects.

An **EADS internship** offers the chance to use your theoretical knowledge and apply it first-hand to real situations and assignments during your studies. Given a high level of responsibility, plenty of learning and development opportunities, and all the support you need, you will tackle interesting challenges on state-of-the-art products.

We welcome more than 5,000 interns every year across disciplines ranging from engineering, IT, procurement and finance, to strategy, customer support, marketing and sales. Positions are available in France, Germany, Spain and the UK.

To find out more and apply, visit www.jobs.eads.com. You can also find out more on our **EADS Careers Facebook page**.

AIRBUS ASTRIUM CASSIDIAN EUROCOPTER

EADS



Typical Supply to several substations on an HV ring main where interruptions to the supply are to be kept to a minimum

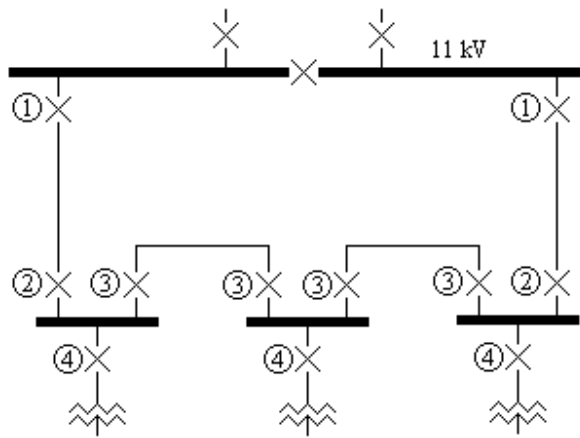

- 1) Feeders Over current and Earth Fault Protection set at 100%, 0.5 sec
- 2) Incomers Directional Overcurrent protection set at 50% 0.1 sec and Directional Earth Fault protection set at 10% 0.1 sec. This provides fault protection for the incoming cable and also prevents feedback via the ring main if the bus section switch in the main substation is opened.
- 3) Inter Connectors Circulating Current protection on the inter connector cable set at 10% 0.1 sec. This requires a pilot wire cable to be laid with the main power cable.
- 4) Transformer Feeder Over current Protection set at 100%, 0.1 sec
Earth Fault Protection set at 10%, 0.1 sec

A fault on any cable is cleared without interrupting the supply to any consumer. Any number of substations can be added to the ring main without increasing the fault clearance times. But the system requires pilot wire cables to be laid with the interconnector cables and this adds to the cost.

Low cost Ring Main System

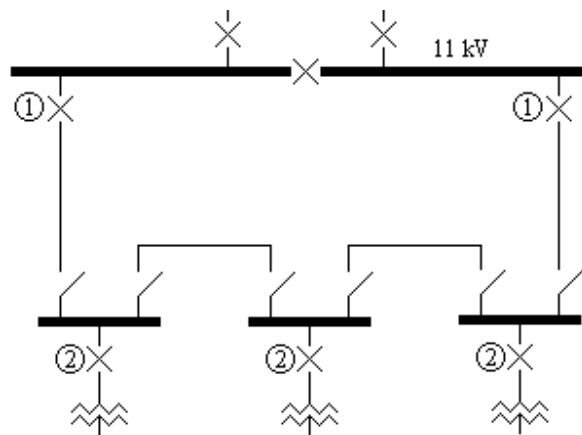

- 1) Feeders
 - Over current Protection set 100%, 0.5 sec
 - Earth Fault Protection set at 10%, 0.5 sec
 - Directional Over current set at 50% 0.1 sec and Directional Earth Fault Protection Set at 10% 0.1 sec.

- 2) Transformer Feeder
 - Over current Protection, 100%, 0.1 sec
 - Earth Fault Protection, 10%, 0.1 sec

This system uses Ring Main Units each containing one circuit breaker and two isolators. The system is operated with one of the isolators open.

If a fault occurs on any cable, then all consumers on the same part of the ring main lose their supply. However the faulty cable can be quickly isolated and power restored to all consumers by opening or closing the appropriate isolators.

The transformer in each substation is protected by the circuit breaker. Some ring main units use the system current to trip the circuit breaker. The circuit breaker has three or four trip coils each connected directly to a current transformer. A fuse is fitted across each trip coil. When the current exceeds the rated value, the fuse blows and the circuit breaker is tripped. Earth fault protection is obtained from a “core balance” current transformer, ie the CT primary contains all three phases. Thus no tripping battery or charger is required.

GENERATOR RESPONSE TO SYSTEM FAULTS

The Initial effect on an ac generator of a short circuit on the power system

The heavy fault current causes a powerful demagnetizing mmf, but by Lenz's law, the change in magnetism is opposed by any coils linked to the flux. Currents are induced in the field circuit and the damper windings to oppose the change in mmf.

These induced currents decay exponentially. The magnetization decays with the flux and this in turn affects the fault current. A heavy fault current is low power factor so the final steady state current (if it were allowed to persist) can fall below the full load value.

The initial value of the fault current is determined by "the emf due to the flux crossing the air gap" acting on the leakage reactance of the generator and the impedance of the external circuit to the fault. The magnetization, the emf, the armature current, the damping winding current and the main field current all decay with the same two time constants due to their interaction through flux linkage.

The manufacturers carry out tests on their generators switching the generator onto a short circuit at full speed and full voltage. The current is recorded and analyzed to obtain the direct axis sub transient, transient and synchronous reactances and the short circuit time constants. Additional tests are sometimes carried out short circuiting the generator through a resistance to obtain the quadrature axis sub transient and synchronous reactances and the sub transient time constant.

A three phase fault contains a dc component on at least two phases as the instantaneous value of the AC voltage cannot be at a value corresponding to zero current on all three phases at the instant that the switch is closed. This dc component decays in a few cycles and its effect is usually ignored. If however there is risk of damage due to the mechanical forces of the fault current, then it is prudent to assume the first peak value of the fault current as 1.8 times the calculated value. The figure of 1.8 is the theoretical two times reduced by the decay over a half cycle.

The symbol "·" will be used to signify "multiplied by".

Works short circuit test

The current recordings of a typical short circuit test would be of this form;

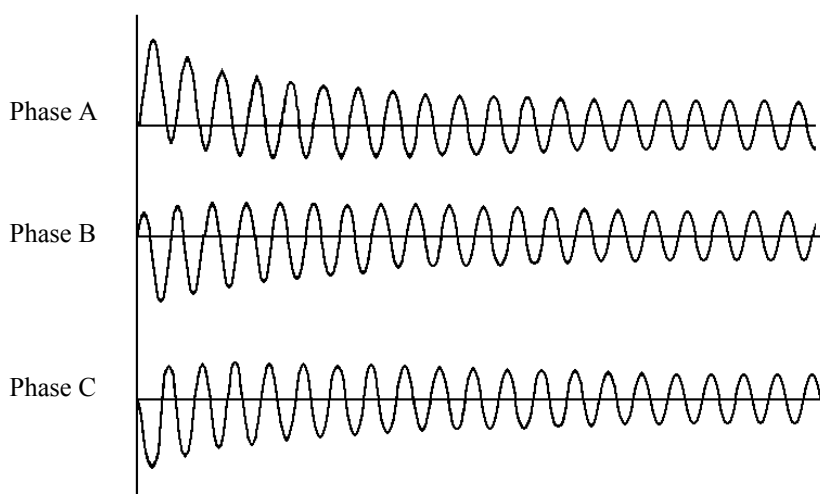

The rms value of the fault current (ignoring the dc component) can be calculated from the recording and will be found to be of this form;

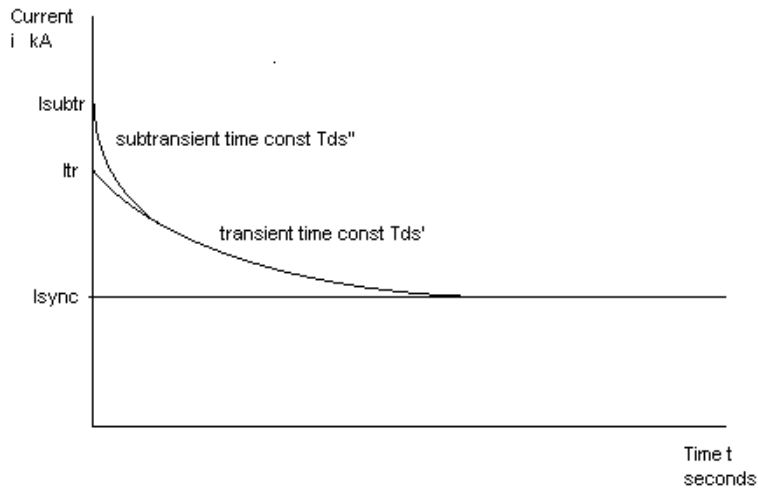

The machine reactances are defined as;
 Subtransient reactance $X_{d}'' = E / I_{subtr}$
 Transient reactance $X_{d}' = E / I_{tr}$
 Synchronous reactance $X_d = \text{slope of oc characteristic near the origin} / \text{slope of sc characteristi}$
 It follows that $X_d = E / I_{sync}$
 Where E is the open circuit emf

360° thinking.

Deloitte.

Discover the truth at www.deloitte.ca/careers

© Deloitte & Touche LLP and affiliated entities.



The initial value of the current I_{subtr} is called the subtransient value.

The leakage reactance X_a is given by $X_a = E / I_{subtr}$

By definition, $X_d'' = E / I_{subtr}$ therefore leakage reactance can be taken as X_d'' .

Extrapolating back along the transient curve gives the transient current I_{tr}

I_{tr} is called the transient value

The transient reactance $X_d' = E / I_{tr}$

Values are obtained for X_d'' , X_d' and X_d by analyzing the recorded current.

The short circuit sub transient time constant T_d'' and the short circuit transient time constant T_d' can also be measured by analysis of the recording.

Similarly, the quadrature parameters X_q'' and T_{qs}'' can be measured by analysis of a recording of the current when the machine is switched onto a low value resistance.

The final steady state value of the current is called the synchronous value I_{sync} . The synchronous reactance, X_d , was defined as the ratio of the slope of the open circuit characteristic near the origin to the slope of the short circuit characteristic.

The rms value of the fault current can be expressed as a function of time

$$I = (I_{subtr} - I_{tr}) e^{-(t/T_d'')} + (I_{tr} - I_{sync}) e^{-(t/T_d')} + I_{sync}$$

Therefore

$$I = (E/X_d'' - E/X_d') e^{-(t/T_d'')} + (E/X_d' - E/X_d) e^{-(t/T_d')} + E/X_d$$

Initial value of the fault current, generator on no load constant excitation switched onto a short circuit reactance X external to the generator.

By Lenz's law, the flux will not change on the instant that a system fault occurs. Currents will be induced in any circuit linking with the flux to give an equal and opposite mmf.

The flux does not change at the instant that the fault occurs. Therefore the emfs also do not change at the instant that the fault occurs. If E is the value of the emf before the fault, the initial value of the fault current (ie the subtransient value) is;

$$I_{subtr} = E / (X_d'' + X)$$

Where E is the value before the fault.

Final value of a short circuit zero impedance external to the generator on constant excitation

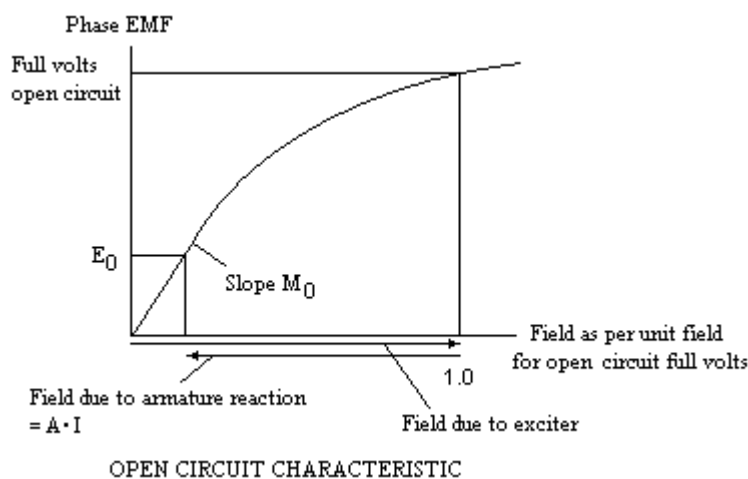

Draw the open circuit curve of phase volts no load against field expressed as fraction of value for open circuit full volts. Draw the short circuit curve of full load current against field expressed as fraction of value for open circuit full volts. Let the slope of the open circuit curve be M_0 near the origin and the slope of the short circuit curve be S .

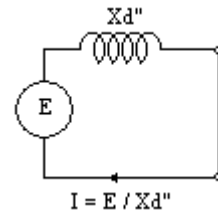
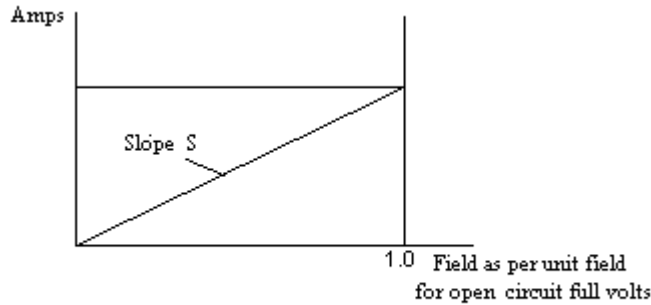

$$I = E / Xd''$$

SHORT CIRCUIT CHARACTERISTIC

With zero impedance external to generator, ie $X = 0$.
 Expressing the reactances in ohms.
 Let I_{sync} be the steady state (ie synchronous) current.
 Therefore $I_{sync} = S$ amps at unity field supplied by the exciter
 The emf, $E_0 = S \cdot Xd''$ volts
 Therefore the net mmf = $E_0 / M_0 = S \cdot Xd'' / M_0$
 But net mmf = $1 - S \cdot A$ where $S \cdot A$ is the mmf due to armature reaction.
 Therefore $S \cdot A = 1 - S \cdot Xd''$
 Therefore $A = 1 / I - Xd'' = 1 / S - Xd''$
Generator on no load constant excitation switched onto an external reactance X

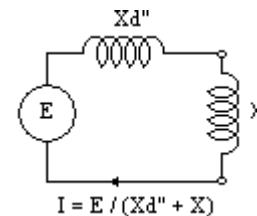
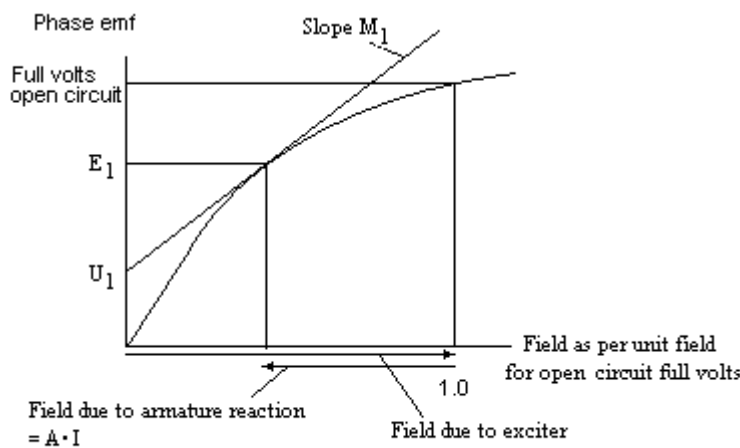

$$I = E / (Xd'' + X)$$

OPEN CIRCUIT CHARACTERISTIC

$$I \cdot (Xd'' + X + (M_1/M_0) \cdot (Xd - Xd'')) = U_1 + M_1$$

$$I = (U_1 + M_1) / [Xd'' + X + (M_1/M_0) \cdot (Xd - Xd'')]$$

If X is small, then $M_0 = M_1$ and $U_1 = 0$
 $I_{sync} = M_0 / (Xd + X)$

Let the tangent to the open circuit curve at the actual emf be $E_1 = U_1 + M_1 \cdot F$
 $I \cdot (Xd'' + X) = E_1 = U_1 + M_1 \cdot F$
 But $F = 1 - I \cdot A$
 $E_1 = I \cdot (Xd'' + X) = U_1 + M_1 \cdot (1 - I \cdot (Xd - Xd'') / M_0)$

If the reactances are in percentages to a base machine MVA, U_1 , M_1 and M_0 are percentage of the open circuit EMF and the current I is per unit of full load current;

$$I = (U + M_1) / [X_{d''} + X + (M_1/M_0) \cdot (X_d - X_{d''})]$$

Where M_0 is the slope of the open circuit curve near the origin and M_1 is the slope at the actual emf.

Transient value of a short circuit zero impedance external to the generator on constant excitation

Let I'' be the part of the current that decays with the time constant $T_{d''}$ and I' be the part that decays with the time constant $T_{d'}$.

Then $I'' = I_{subtr} - I_{tr} = E / X_{d''} - E / X_d$

And $I' = I_{tr} - I_{sync} = E / X_{d'} - E / X_d$

And $I'' + I' = E / X_{d''} - E / X_d$

Thus $I'' = (I' + I'') \cdot (1/X_{d''} - 1/X_d) / (1/X_{d''} - 1/X_d)$.

And $I' = (I' + I'') \cdot (1/X_{d'} - 1/X_d) / (1/X_{d''} - 1/X_d)$.

SIMPLY CLEVER





We will turn your CV into an opportunity of a lifetime

Do you like cars? Would you like to be a part of a successful brand?
 We will appreciate and reward both your enthusiasm and talent.
 Send us your CV. You will be surprised where it can take you.

Send us your CV on
www.employerforlife.com

Transient value of a short circuit with impedance X external to the generator on constant excitation and on no load.

The situation becomes a little murky when there is impedance in the fault path external to the generator. Traditional theory assumes the machine reactance changes from sub transient through transient to synchronous reactance and adds these to the external impedance, all the time keeping the emf constant. This is the opposite to what actually happens. The impedance is not changing. It remains at $X_a + Z$ where X_a is the leakage reactance and Z is the external impedance. It is the emf which changes.

Currents are induced in the main field winding and in the damper winding. These depend on the number of turns, the circuit impedance and the rate of change of flux. If the rate of change in flux is doubled, the emf in both windings is doubled. The circuit impedances are not changed. Therefore both currents are doubled. Thus the currents are in the same ratio whether the rate of change in flux is high or low. With external reactance X , the ratio of the subtransient component I'' to transient component I' is the same as for the fault with $X = 0$.

$$I'' + I' = I_{subtr} - I_{sync}$$

$$\text{Thus the subtransient component } I'' = (I_{subtr} - I_{sync}) \cdot (1/X_d'' - 1/X_d') / (1/X_d'' - 1/X_d)$$

$$\text{And the transient component } I' = (I_{subtr} - I_{sync}) \cdot (1/X_d' - 1/X_d) / (1/X_d'' - 1/X_d).$$

Hence the fault current can be expressed as;

$$I = I'' e^{-(t/T_d'')} + I' e^{-(t/T_d')} + I_{sync}$$

Where

$$I'' = (I_{subtr} - I_{sync}) \cdot (1/X_d'' - 1/X_d') / (1/X_d'' - 1/X_d)$$

$$I' = (I_{subtr} - I_{sync}) \cdot (1/X_d' - 1/X_d) / (1/X_d'' - 1/X_d).$$

Several textbooks quote;

$$I = [E/(X_d'' + X) - E/(X_d' + X)] e^{-(t/T_d'')} + [E/(X_d' + X) - E/(X_d + X)] e^{-(t/T_d')} + E/(X_d + X)$$

If this equation is correct, then the ratio of the subtransient component to the transient component is;

$$\begin{aligned} \text{Ratio} &= [E/(X_d'' + X) - E/(X_d' + X)] / [E/(X_d' + X) - E/(X_d + X)] \\ &= [(X_d' + X - X_d'' - X) / \{(X_d'' + X) \cdot (X_d' + X)\}] / [(X_d + X - X_d' - X) / \{(X_d' + X) \cdot (X_d + X)\}] \\ &= [(X_d' - X_d'') / (X_d'' + X)] / [(X_d - X_d') / (X_d + X)] \\ &= [(X_d' - X_d'') \cdot (X_d + X)] / [(X_d'' + X) \cdot (X_d - X_d')] \end{aligned}$$

If X is very large

$$\text{Ratio} = (X_d' - X_d'') / (X_d - X_d')$$

If $X = 0$

$$\text{Ratio} = X_d \cdot (X_d' - X_d'') / [X_d'' \cdot (X_d - X_d')]$$

$$(\text{Ratio when } X \text{ is } 0) = X_d/X_d'' \cdot (\text{Ratio when } X \text{ is large})$$

These Ratios should be the same but the value of X_d/X_d'' is typically more than 10

This suggests there is a flaw in equation;

$$I = [E/(X_d'' + X) - E/(X_d' + X)] e^{-(t/T_d'')} + [E/(X_d' + X) - E/(X_d + X)] e^{-(t/T_d')} + E/(X_d + X)$$

Net impedance of the load and fault

For simplicity it will be assumed that the load impedance remains unchanged during the fault and is in parallel with the fault impedance. This is not strictly true if the load is largely induction motors. With induction motors, a reduction in voltage causes an increase in current and in extreme cases the effect can avalanche.

Let the load be equivalent to an impedance $Z_L = R_L + jX_L$ and the fault be a three phase fault with impedance $Z_F = R_F + jX_F$ in parallel with the load. The combined impedance $R + jX$ can be calculated.

$$\begin{array}{ll} \text{Put} & A = R_L / Z_L^2 + R_F / Z_F^2 & \text{And} & B = X_L / Z_L^2 + X_F / Z_F^2 \\ \text{Then} & R = A / (A^2 + B^2) & \text{And} & X = B / (A^2 + B^2) \end{array}$$

Generator response during a fault

The initial values of magnetism and hence the emfs have the same value immediately after the fault occurs that they had before the fault. The armature reaction of the fault current is balanced exactly by currents induced in the damping winding and field circuit. Thereafter, the induced currents decay exponentially and the magnetism decays with the same time constants. There are two coils linked with the magnetic circuit on the direct axis, the main field and the damping winding, leading to two time constants T_d'' and T_d' . On the quadrature axis there is one coil linking with the magnetic circuit, the damping winding, leading to one time constant T_q'' . The fault current equals the emf/impedance. The emf is proportional to the flux, hence the fault current is proportional to the flux and decays with the same time constants.

On a zero impedance fault, the time constants are denoted by T_{ds}'' , T_{ds}' and T_{q}'' . On open circuit, the time constants are denoted by T_{do}'' , T_{do}' and T_{qo}'' .

Value of parameters before the fault.

Before the fault, the value of all parameters can be obtained from the on load vector diagram as described for the ac generator. These are given the suffix L.

Suffix L will be used to indicate values while on Load before the fault

Suffix 0 will be used to indicate values at the start of the fault (ie $t = 0$)

Suffix t will be used to indicate values at t seconds after the start of the fault

Suffix C will be used to indicate values immediately after the fault is Cleared

Suffix s will be used to indicate values s seconds after the fault has been cleared

Value of parameters immediately after the fault occurs (ie t = 0 during the fault)

The vector diagram at the fault incidence (ie t = 0) becomes;

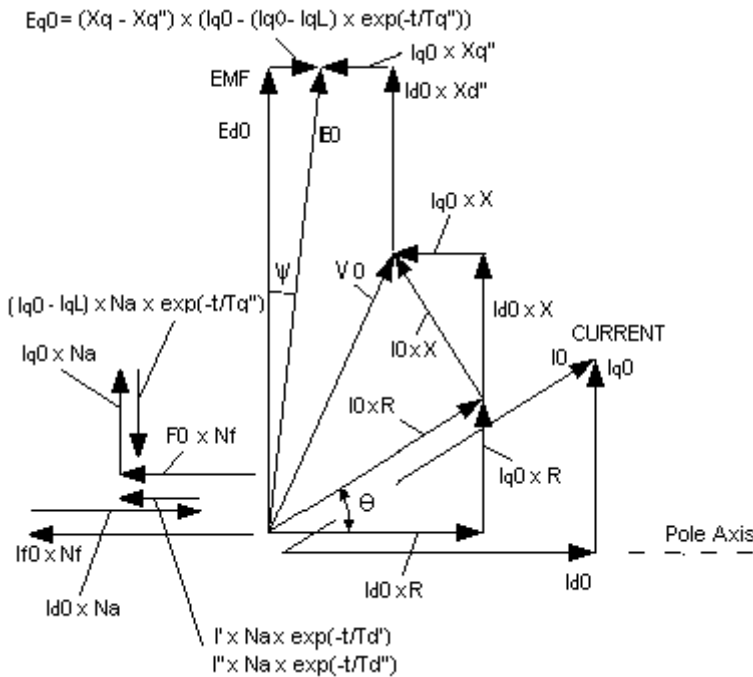

Parameters are given the suffix 0 to indicate their value at time t=0. The total emf and flux (hence ampere turns) on each axis do not change immediately when the fault occurs. Therefore $E_0 = E_L$, $E_{q0} = E_{qL}$, $E_{d0} = E_{dL}$ and the total mmf on each axis is initially unchanged.

On the diagram;

$\sin \psi = E_{q0} / E_0$ and $E_{d0} = E_0 \cos \psi$

Resolving horizontally and vertically;

$I_{q0} \times R + I_{d0} \times (X + X_{d''}) = E_{d0}$

$I_{d0} \times R = E_{q0} + I_{q0} \times (X + X_{q''})$

Therefore

$$I_{d0} = [E_{q0} \cdot R + E_{d0} \cdot (X + X_{q''})] / [R^2 + (X + X_{d''}) (X + X_{q''})]$$

$$I_{q0} = [E_{d0} \cdot R - E_{q0} \cdot (X + X_{d''})] / [R^2 + (X + X_{d''}) (X + X_{q''})]$$

Put $c_1 = (X + X_{q''}) / [R^2 + (X + X_{d''}) (X + X_{q''})]$

$c_2 = c_1 \cdot R / (X + X_{q''})$

$c_3 = c_1 \cdot (X + X_{d''}) / (X + X_{q''})$

Then $I_{d0} = c_1 \cdot E_{d0} + c_2 \cdot E_{q0}$

And $I_{q0} = c_2 \cdot E_{d0} - c_3 \cdot E_{q0}$

These relationships also apply with suffix t since R and X are unchanged.

Hence the values of I_0 and V_0 can be calculated.

$$I_0 = \sqrt{(I_{d0}^2 + I_{q0}^2)}$$

$$V_0 = I_0 \times \sqrt{(R^2 + X^2)}$$

Let the transient direct axis components of the fault current be I'' decaying with time constant T_d'' and I' decaying with time constant T_d' .

The fault current decays from the initial value I_{subtr} to the final value I_{sync} .

The initial currents induced in the damping winding and the main field winding are determined by the flux linkage and the impedance of the circuits. Thus the ratio of these induced currents is always the same.

It will be assumed that the ratio I'' / I' is also the same for all faults.

On short circuit; $I'' = (I' + I'') * (1/X_d'' - 1/X_d') / (1/X_d'' - 1/X_d)$
and $I' = (I' + I'') * (1/X_d' - 1/X_d) / (1/X_d'' - 1/X_d)$.

At the instant of the fault, the armature current changes from I_{dL} to I_{d0} .

Therefore, we could put $(I' + I'') = I_{d0} - I_{dL}$

However the final value is determined by the armature reaction.

Therefore it is better to put

$(I' + I'') = I_{d0} - \text{Final value of fault current}$

I joined MITAS because
I wanted **real responsibility**

The Graduate Programme
for Engineers and Geoscientists
www.discovermitas.com



Month 16

I was a construction
supervisor in
the North Sea
advising and
helping foremen
solve problems

Real work
International opportunities
Three work placements





Let F_0 be the field current that would give the same ampere turns as the net ampere turns on the direct axis.

$$F_0 \times N_f = I_f L \cdot N_f + [I'' \exp(-t/T_d'') + I' \exp(-t/T_d') - I_{d0}] \cdot N_a$$

where $N_a / N_f = (X_d - X_d'')/M_1$

$$F_0 = I_{f0} + [I'' \exp(-t/T_d'') + I' \exp(-t/T_d') - I_{d0}] \cdot (X_d - X_d'')/M_1$$

Initially, the ampere turns are unchanged hence $F_0 = F_L$ and $I_{f0} = I_{fL}$

The net ampere turns on the quadrature axis are;

$$I_{q0} \cdot N - (I_{q0} - \text{Final value of } I_q) \cdot N \exp(-t/T_q'')$$

Values of the parameters during the fault t seconds after the start of the fault

$$E_{qt} = (X_q - X_q'') \times (I_{qt} - (I_{q0} - I_{qL}) \times \exp(-t/T_q''))$$

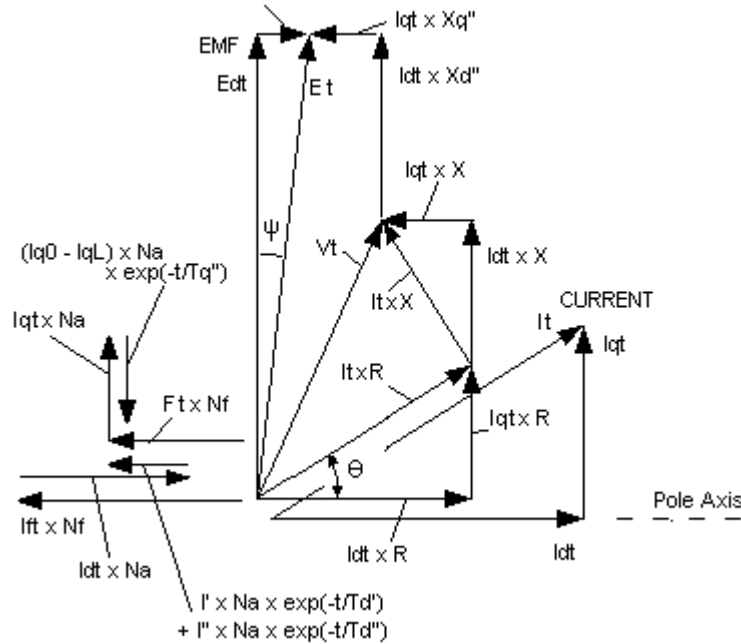

The suffix t indicates the value during the fault at t seconds after the incidence of the fault and the vector diagram becomes as shown. The time constants T_d'' , T_d' and T_q'' will have values between the short circuit and open circuit values.

Field current on the direct axis that would produce the same ampere turns;

$$F_{et} = F_t + [I'' \exp(-t/T_d'') + I' \exp(-t/T_d') - Idt] \cdot N$$

Put $c_4 = F_t + [I'' \exp(-t/T_d'') + I' \exp(-t/T_d')] \cdot N$

Where $N = (X_d - X_d'')/M_1$

On the Direct axis;

$$\begin{aligned} E_t &= U + M \cdot c_4 - M \cdot Idt \cdot N \\ &= U + M \cdot c_4 - M \cdot Idt \cdot (X_d - X_d'')/M_1 \end{aligned}$$

Put $c_5 = U + M \cdot c_4$

and $c_6 = M \cdot (X_d - X_d'')/M_1$

Then $E_t = c_5 - c_6 \cdot Idt$

On the Quad axis;

$$E_{qt} = (X_q - X_q'') \cdot [I_{qt} - (I_{q0} - I_{qL}) \cdot \exp(-t/T_q'')]]$$

Put $c_7 = (X_q - X_q'')$

and $c_8 = c_7 \cdot (I_{q0} - I_{qL}) \cdot \exp(-t/T_q'')$

Then $E_{qt} = c_7 \cdot I_{qt} - c_8$

But $I_{qt} = c_2 \cdot E_{dt} - c_3 \cdot E_{qt}$

$$E_{qt} = c_7 \cdot c_2 \cdot E_{dt} - c_7 \cdot c_3 \cdot E_{qt} - c_8$$

Put $c_9 = c_7 \cdot c_2 / (1 + c_7 \cdot c_3)$

and $c_{10} = c_8 / (1 + c_7 \cdot c_3)$

Then $E_{qt} = c_9 \cdot E_{dt} - c_{10}$

But $E_t = c_5 - c_6 \cdot Idt$

and $Idt = c_1 \cdot E_{dt} + c_2 \cdot E_{qt}$

Thus
$$\begin{aligned} E_t &= c_5 - c_6 \cdot c_1 \cdot E_{dt} - c_6 \cdot c_2 \cdot E_{qt} \\ &= c_5 - c_6 \cdot c_1 \cdot E_{dt} - c_6 \cdot c_2 \cdot c_9 \cdot E_{dt} + c_6 \cdot c_2 \cdot c_{10} \\ &= c_5 + c_6 \cdot c_2 \cdot c_{10} - (c_6 \cdot c_1 + c_6 \cdot c_2 \cdot c_9) \cdot E_{dt} \end{aligned}$$

Put $c_{13} = c_6 \cdot c_1 + c_6 \cdot c_2 \cdot c_9$

and $c_{14} = c_5 + c_6 \cdot c_2 \cdot c_{10}$

Then $E_t = c_{14} - c_{13} \cdot E_{dt}$

But $E_t^2 = E_{dt}^2 + E_{qt}^2$

Substitute to get a quadratic in E_{dt}

$$[c_{14} - c_{13} \cdot E_{dt}]^2 = E_{dt}^2 + [c_9 \cdot E_{dt} - c_{10}]^2$$

Put $c_{15} = 1 + c_9^2 - c_{13}^2$

and $c_{16} = 2 \cdot c_{14} \cdot c_{13} - 2 \cdot c_9 \cdot c_{10}$

and $c_{17} = c_{10}^2 - c_{14}^2$

Finally $E_{dt} = [-c16 + \sqrt{(c16^2 - 4 \cdot c15 \cdot c17)}] / (2 \cdot c15)$
 Hence $E_{qt} = c9 \cdot E_{dt} - c10$
 and $E_t = \sqrt{(E_{dt}^2 + E_{qt}^2)}$
 and $I_{qt} = c2 \cdot E_{dt} - c3 \cdot E_{qt}$
 and $I_{dt} = c2 \cdot E_{qt} + c1 \cdot E_{dt}$
 and $I_t = \sqrt{(I_{dt}^2 + I_{qt}^2)}$
 and $V_t = I_t / \sqrt{(R^2 + X^2)}$

Evaluation of the Time constants

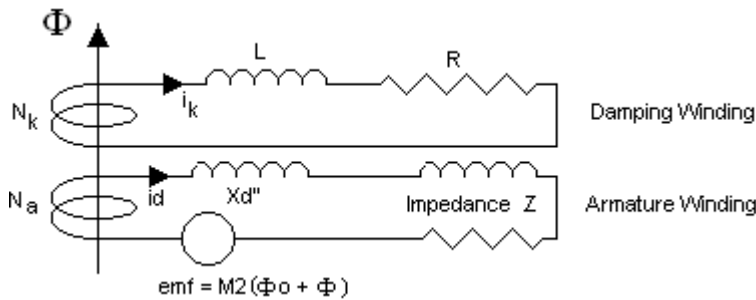

Consider the case of a generator on no load with a single coil linking the field. Let the magnetic flux be Φ_0 . A fault occurs with an impedance Z . This causes an armature current with direct axis component i_d .

$$i_d = [emf / (Z + X_{d''})] \cos \theta$$

where $X_{d''}$ is the generator leakage reactance and θ is the angle between the armature current and the direct axis.

“I studied English for 16 years but...
 ...I finally learned to speak it in just six lessons”
 Jane, Chinese architect

ENGLISH OUT THERE

Click to hear me talking before and after my unique course download



The ampere turns of this current ($N_a \cdot i_d$) act to reduce the flux and induce a current i_k in the linked coil. The ampere turns of this coil ($N_k \cdot i_k$) initially exactly equal ($N_a \cdot i_d$) and the flux is initially unchanged. ($N_k \cdot i_k$) increases the flux while ($N_a \cdot i_d$) reduces it.

Let Φ be the increase in flux.

$$\Phi = M_1 (N_k \cdot i_k - N_a \cdot i_d)$$

where M_1 is the slope of the magnetisation curve at open circuit full volts (flux against ampere turns)

Let the emf = M_2 times the flux

The direct axis component of the armature current is

$$i_d = [M_2 (\Phi_0 + \Phi) / (Z + X_d'')] \cos \theta$$

Substitute i_d in the equation for Φ

$$\Phi = M_1 \cdot N_k \cdot i_k - M_1 \cdot N_a \cdot [M_2 (\Phi_0 + \Phi) / (Z + X_d'')] \cos \theta$$

Differentiate

$$d\Phi/dt = M_1 \cdot N_k \cdot di_k/dt - M_1 \cdot N_a \cdot [M_2 \cdot d\Phi/dt] / (Z + X_d'') \cos \theta$$

$$d\Phi/dt [1 + M_1 \cdot N_a \cdot \{M_2 / (Z + X_d'')\} \cos \theta] = M_1 \cdot N_k \cdot di_k/dt$$

Let $P = M_1 \cdot N_k / [1 + M_1 \cdot N_a \cdot \{M_2 / (Z + X_d'')\} \cos \theta]$

$$d\Phi/dt = P \cdot di_k/dt$$

Let the emf induced in the coil be M_3 times $d\Phi/dt$. A falling flux creates a positive i_k

$$-M_3 \cdot d\Phi/dt = R \cdot i_k + L \cdot di_k/dt$$

Where R and L are the resistance and leakage reactance of the coil.

Let $Q = M_3 \cdot P + L$

Hence $R \cdot i_k + Q \cdot di_k/dt = 0$

$$(R/Q) \cdot i_k + di_k/dt = 0$$

Multiply by the integrating factor $\text{EXP}\{(R/Q)t\}$

$$(R/Q) \cdot \text{EXP}\{(R/Q)t\} \cdot i_k + \text{EXP}\{(R/Q)t\} \cdot di_k/dt = 0$$

$$d[\text{EXP}\{(R/Q)t\} \cdot i_k]/dt = 0$$

Integrate $\text{EXP}\{(R/Q)t\} \cdot i_k = \text{Constant}$

When $t = 0$, $i_k = i_{k0}$

Therefore $i_k = i_{k0} \cdot \text{EXP}(-t/T)$

Where the time constant $T = Q/R = (M_3 \cdot P + L)/R$

Put $T = T_1 + T_2$

where $T_1 = L/R$

and $T_2 = M_3 \cdot P / R = M_3 \cdot M_1 \cdot N_k / [1 + M_1 \cdot N_a \cdot \{M_2 / (Z + X_d'')\} \cos \theta] / R$

T_1 is the time constant of the coil due to resistance and leakage reactance

T_2 is the time constant of the coil due to resistance and flux linkage

Thus T_2 is very much larger than T_1 and T_1 can be ignored

Put $\alpha = M_3 \cdot M_1 \cdot N_k / R$

And $\beta = M_1 \cdot N_a \cdot M_2 / X_d''$

And $k = [X_d'' / (Z + X_d'')] \cos \theta$

$$T_2 = \alpha / (1 + \beta \cdot k)$$

When Z is very large (ie open circuit), $k = 0$, $T_2 = T_{do}''$ therefore $\alpha = T_{do}''$

When $Z = 0$, (ie short circuit), $k = 1$, $T_2 = T_{ds}''$

$$T_{ds}'' = T_{do}'' / (1 + \beta) \text{ therefore } \beta = (T_{do}'' - T_{ds}'') / T_{ds}''$$

Therefore for other values of Z;

$$T_d'' = T_2 = T_{do}'' \cdot T_{ds}'' / [T_{ds}'' + (T_{do}'' - T_{ds}'') \cdot k]$$

But if fact there are two coils linking with the magnetic circuit with open circuit time constants T_{do}'' and T_{do}' respectively and the ampere turns is the sum of the ampere turns of the two circuits.

Therefore, putting I_{d0}/I_0 for $\cos \theta$ and I_{q0}/I_0 for $\sin \theta$

$$T_d'' = T_{do}'' \cdot T_{ds}'' / [T_{ds}'' + (T_{do}'' - T_{ds}'') \cdot k]$$

$$\text{Where } k = [X_d'' / (Z + X_d'')] I_{d0}/I_0$$

Similarly

$$T_d' = T_{do}' \cdot T_{ds}' / [T_{ds}' + (T_{do}' - T_{ds}') \cdot k]$$

$$\text{Where } k = [X_d'' / (Z + X_d'')] I_{d0}/I_0$$

And

$$T_q'' = T_{qo}'' \cdot T_{qs}'' / [T_{qs}'' + (T_{qo}'' - T_{qs}'') \cdot k]$$

$$\text{Where } k = [X_q'' / (Z + X_q'')] I_{q0}/I_0$$

Summary of Ampere Turns on each axis

Direct Axis

Event	Exciter	Armature	Induced mmf	Total
On Load	FeL = Fe + N*IdL	- N*IdL	0	Fe
t = 0 during the fault	FeL = Fe + N*IdL	- N*Id0	N * (Id0 - IdL) = N*(I1+I2)	Fe
Time t during the fault	FeL = Fe + N*IdL	- N*Idt	N* [I1*exp(-t/Td1) + I2*exp(-t/Td2)]	Ft
s = 0 after clearance	FeL = Fe + N*IdL	- N*IdC	N*(I1C+I2C)	Ft
Time s after clearance	FeL = Fe + N*IdL	- N*Ids	N*[I1C*exp(-s/Td1C) + I2C*exp(-s/Td2C)]	Fs

On this table, the excitation is assumed constant

Fe is the excitation to give open circuit full volts

Add horizontal lines to get the total;

$$I_1 + I_2 = I_{d0} - I_{dL}$$

$$F_t = Fe + N*IdL - N*Idt + N*(I_1*exp(-t/Td1)+I_2*exp(-t/Td2))$$

$$I_1C + I_2C = [F_t - Fe - N*IdL + N*IdC] / N$$

$$F_s = Fe + N*IdL - N*Ids + N*I_1C*exp(-s/Td1C) + N*I_2C*exp(-s/Td2C)$$

Quadrature axis

Event	Armature	Induced mmf	Total
On Load	$N * I_{qL}$	0	$N * I_{qL}$
$t = 0$ during the fault	$N * I_{q0}$	$N * (I_{qL} - I_{q0})$ $= - N * I_3$	$N * I_{qL}$
Time t during the fault	$N * I_{qt}$	$- N * I_3 * \exp(-t/T_{q2})$	$N * [I_{qt} - I_3 * \exp(-t/T_{q2})]$
$S = 0$ after clearance	$N * I_{qC}$	$N * [I_{qt} - I_{qC}$ $- I_3 * \exp(-t/T_{q2})]$ $= - N * I_3C$	$N * [I_{qt} - I_3 * \exp(-t/T_{q2})]$
Time s after clearance	$N * I_{qs}$	$- N * I_3C * \exp(-s/T_{q2C})$	$N * [I_{qs}$ $- I_3C * \exp(-s/T_{q2C})]$

$I_3 = I_{q0} - I_{qL}$

$I_3C = I_3 * \exp(-t/T_{q2}) - I_{qt} + I_{qC}$

Exciter response

The main field current due to the pilot exciter has been assumed to be constant during the fault. It therefore has played no part in the changing flux. In practice however the exciter current does change rapidly under the control of the Automatic Voltage Regulator. While the voltage V_t remains below the reference voltage, the pilot exciter, and hence the main exciter will be boosting at their maximum rate.

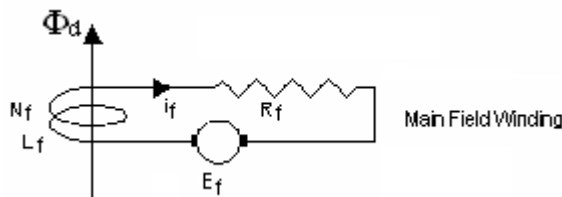



WHILE YOU WERE SLEEPING...

www.fuqua.duke.edu/whileyouweresleeping





The exciter response when boosting is;

$$E_f = E_{f_{\max}} - (E_{f_{\max}} - E_{f_0}) \cdot \text{Exp}(-t/T_e)$$

Where T_e is the time constant of the combination of exciter and pilot exciter.

This is applied to the main field winding, resistance R_f and inductance L_f .

Let the time constant of this winding be T_d .

$$T_d = L_f / R_f$$

$$E_f = L_f \cdot di_f / dt + R_f \cdot i_f$$

Multiply by the integrating factor $\text{Exp}(t/T_d)$

$$\begin{aligned} L_f \cdot d/dt [i_f \cdot \text{Exp}(t/T_d)] &= E_f \cdot \text{Exp}(t/T_d) \\ &= E_{f_{\max}} \cdot \text{Exp}(t/T_d) - (E_{f_{\max}} - E_{f_0}) \cdot \text{Exp}[t \cdot (1/T_d - 1/T_e)] \end{aligned}$$

Integrate;

$$\begin{aligned} L_f \cdot [i_f \cdot \text{Exp}(t/T_d)] &= E_{f_{\max}} \cdot T_d \cdot \text{Exp}(t/T_d) \\ &\quad - (E_{f_{\max}} - E_{f_0}) / (1/T_d - 1/T_e) \cdot \text{Exp}[t \cdot (1/T_d - 1/T_e)] + C \\ i_f &= E_{f_{\max}} \cdot T_d / L_f - (E_{f_{\max}} - E_{f_0}) / (1/T_d - 1/T_e) / L_f \cdot \text{Exp}(-t/T_e) \\ &\quad + C \cdot \text{Exp}(-t/T_d) \end{aligned}$$

$$i_f = E_{f_{\max}} / R_f - (E_{f_{\max}} - E_{f_0}) / R_f / (1 - T_d/T_e) \cdot \text{Exp}(-t/T_e) + C \cdot \text{Exp}(-t/T_d)$$

But $E_{f_{\max}} / R_f = I_{f_{\max}}$ and $E_{f_0} / R_f = I_{f_0}$

$$i_f = I_{f_{\max}} - (I_{f_{\max}} - I_{f_0}) \cdot T_e / (T_e - T_d) \cdot \text{Exp}(-t/T_e) + C \cdot \text{Exp}(-t/T_d)$$

When $t = 0$, $i_f = i_{f_0}$

Therefore $C = i_{f_0} - I_{f_{\max}} + (I_{f_{\max}} - I_{f_0}) \cdot T_e / (T_e - T_d)$

$$= (I_{f_{\max}} - I_{f_0}) \cdot T_d / (T_e - T_d)$$

$$i_f = I_{f_{\max}} - (I_{f_{\max}} - I_{f_0}) / (T_e - T_d) \cdot [T_e \cdot \text{Exp}(-t/T_e) - T_d \cdot \text{Exp}(-t/T_d)]$$

But in fact there are two time constants T_d' and T_d'' . The effect of each can be apportioned by the factors $I' / (I' + I'')$ and $I'' / (I' + I'')$

A problem occurs if T_d equals T_e as coefficients in the equation for i_f become infinitely large.

Let $1/T_d = 1/T_e + d$ and take the limit as d tends to zero.

$$T_d = T_e - T_d \cdot T_e \cdot d$$

$$\begin{aligned} \text{Exp}(-t/T_d) &= \text{Exp}[-t \cdot (1/T_e + d)] = \text{Exp}(-t/T_e) \cdot \text{Exp}(-t \cdot d) \\ &= \text{Exp}(-t/T_e) \cdot (1 - (t \cdot d) + (t \cdot d)^2 / 2 + \text{higher powers of } d) \end{aligned}$$

$$\begin{aligned} i_f &= I_{f_{\max}} - (I_{f_{\max}} - I_{f_0}) / (T_e - T_d) \cdot [T_e \cdot \text{Exp}(-t/T_e) - T_d \cdot \text{Exp}(-t/T_d)] \\ &= I_{f_{\max}} - (I_{f_{\max}} - I_{f_0}) / (T_e \cdot T_d \cdot d) \cdot \text{Exp}(-t/T_e) \\ &\quad \cdot [T_e - (T_e - T_d \cdot T_e \cdot d) \cdot (1 - (t \cdot d) + (t \cdot d)^2 / 2)] \\ &= I_{f_{\max}} - (I_{f_{\max}} - I_{f_0}) \cdot (t/T_d + 1) \cdot \text{Exp}(-t/T_e) + \text{higher powers of } d \end{aligned}$$

Limit i_f as d approaches zero

$$i_f = I_{f_{\max}} - (I_{f_{\max}} - I_{f_0}) \cdot (t/T_d + 1) \cdot \text{Exp}(-t/T_e)$$

If the voltage recovers to the reference voltage then the AVR no longer calls for an increase in excitation. All the parameters need to be recalculated on the basis of the busbar voltage being equal to the AVR reference voltage, ie the rated value plus or minus the compounding.

Step by step evaluation of the fault current

The following information is needed;

Generator size MVA and MW and voltage kV

Generator reactances $X_d, X_d'', X_d', X_q, X_q'', X_{neg}, X_{zero}$

Generator time constants $T_{ds}'', T_{ds}', T_{qs}'', T_{do}'', T_{do}', T_{qo}''$

Generator open circuit curve $m_1, U_2, m_2, U_3, m_3, U_4, m_4$

Maximum and minimum exciter voltage as per unit of value for OC full volts

Generator compounding voltage on full load as % system volts

Generator compounding voltage phase angle

Generator governor droop as % speed change no load to full load

Generator inertia H in kW seconds per kVA at rated speed

Full load expressed as system resistance R_L and reactance X_L

Fault impedance to power station busbars as R_F and X_F

Lines beginning with * are for information and are not part of the step by step procedure.

$$A = R_L / Z_L^2 + R_F / Z_F^2$$

$$B = X_L / Z_L^2 + X_F / Z_F^2$$

$$R = A / (A^2 + B^2)$$

$$X = B / (A^2 + B^2)$$

$$\tan \theta_L = R_L / (X_q + X_L)$$

$$I_L = V / \sqrt{R_L^2 + X_L^2}$$

$$I_{dL} = I_L \cdot \cos \theta_L$$

$$I_{qL} = I_L \cdot \sin \theta_L$$

$$E_{qL} = I_{qL} \cdot (X_q - X_q'')$$

$$E_L = \sqrt{[I_{qL} \cdot R_L + I_{dL} \cdot (X_L + X_d'')]^2 + E_{qL}^2}$$

$$I_{fL} = (E_L - U_2) / M_2 + I_{dL} \cdot (X_d - X_d'') / M_1$$

$$\sin \psi = E_{qL} / E_L$$

$$\cos \psi = \sqrt{1 - \sin^2 \psi}$$

$$E_{q0} = E_{qL}$$

$$E_{d0} = E_{dL}$$

$$E_0 = E_L$$

$$I_{f0} = I_{fL}$$

$$c_1 = (X + X_q'') / [R^2 + (X + X_d'')(X + X_q'')]$$

$$c_2 = c_1 \cdot R / (X + X_q'')$$

$$c_3 = c_1 \cdot (X + X_d'') / (X + X_q'')$$

$$I_{d0} = c_2 \cdot E_{q0} + c_1 \cdot E_{d0}$$

$$I_{q0} = c_2 \cdot E_{d0} - c_3 \cdot E_{q0}$$

$$I_0 = \sqrt{I_{d0}^2 + I_{q0}^2}$$

$$Z = \sqrt{R^2 + X^2}$$

$$V_0 = I_0 \cdot Z$$

$$T_d'' = T_{do}'' \cdot T_{ds}'' / [T_{ds}'' + (T_{do}'' - T_{ds}'') \cdot (I_{d0}/I_0) \cdot X_d'' / \sqrt{R^2 + (X + X_d'')^2}]$$

$$T_d' = T_{do}' \cdot T_{ds}' / [T_{ds}' + (T_{do}' - T_{ds}') \cdot (I_{d0}/I_0) \cdot X_d' / \sqrt{R^2 + (X + X_d')^2}]$$

$$T_q'' = T_{qo}'' \cdot T_{qs}'' / [T_{qs}'' + (T_{qo}'' - T_{qs}'') \cdot (I_{q0}/I_0) \cdot X_q'' / \sqrt{R^2 + (X + X_q'')^2}]$$

$$I'' = (I_{d0} - I_{dL}) \cdot (1/X_d'' - 1/X_d') / (1/X_d'' - 1/X_d)$$

$$I' = (I_{d0} - I_{dL}) \cdot (1/X_d' - 1/X_d) / (1/X_d' - 1/X_d)$$

Choose a value for t

$I_f t = I_{f_{\max}} - (I_{f_{\max}} - I_{fL}) \exp(-t/T_e)$ provided the voltage has not recovered.

Lines beginning with * are for information, not in the step by step evaluation.

$$c4 = I_f t + [I' \cdot \exp(-t/T_d') + I'' \cdot \exp(-t/T_d'')] \cdot (X_d - X_d'')/M_1$$

$$c5 = \text{freq}_t/\text{freq} \cdot (U + m \cdot c4)$$

$$c6 = \text{freq}_t/\text{freq} \cdot (X_d - X_d'')/M_1$$

* Then $E_t = U + M \cdot (c5 - c6 \cdot I_d t)$ corrected for speed change

$$c7 = \text{freq}_t/\text{freq} \cdot (X_q - X_q'')$$

$$c8 = c7 \cdot (I_{q0} - I_{qL}) \cdot \exp(-t/T_q'')$$

* then $E_{qt} = c7 \cdot I_{qt} - c8$ corrected for speed change

$$* \text{ but } I_{qt} = c2 \cdot E_{dt} - c3 \cdot E_{qt}$$

* substitute for I_{qt} to get $E_{qt} = c9 \cdot E_{dt} - c10$, where;

$$c9 = c7 \cdot c2 / (1 + c7 \cdot c3)$$

$$c10 = c8 / (1 + c7 \cdot c3)$$

* also $E_t = U + M \cdot (c5 - c6 \cdot I_d t)$

* and $I_d t = c2 \cdot E_{qt} + c1 \cdot E_{dt}$

* substitute for $I_d t$ and E_{qt} to get $E_t = c14 - c13 \cdot E_{dt}$, where;

$$c13 = c6 \cdot c2 \cdot c9 + c6 \cdot c1$$

$$c14 = c5 + c6 \cdot c2 \cdot c10$$

* but $E_t^2 = E_{qt}^2 + E_{dt}^2$

* substituting for E_t and E_{qt} gives a quadratic in E_{dt}

* $c15 \cdot E_{dt}^2 - c16 \cdot E_{dt} + c17 = 0$, where;

$$c15 = 1 + c9^2 - c13^2$$

$$c16 = 2 \cdot c14 \cdot c13 - 2 \cdot c9 \cdot c10$$

$$c17 = c10^2 - c14^2$$

* hence;

$$E_{dt} = [-c16 + \sqrt{(c16^2 - 4 \cdot c15 \cdot c17)}] / (2 \cdot c15)$$

$$E_{qt} = c9 \cdot E_{dt} - c10$$

$$E_t^2 = \sqrt{E_{qt}^2 + E_{dt}^2}$$

$$I_{qt} = c2 \cdot E_{dt} - c3 \cdot E_{qt}$$

$$I_d t = c2 \cdot E_{qt} + c1 \cdot E_{dt}$$

$$I_t^2 = \sqrt{I_{qt}^2 + I_d t^2}$$

$$V_t = I_t \cdot \sqrt{R^2 + X^2}$$

These equations evaluate the emfs, the fault current and power station busbar voltage at any time t seconds after the fault occurs.

If the exciter can restore the voltage to normal volts before the fault is cleared, then the AVR will cease to call for an increase in the field current.

The frequency at time t seconds after the fault occurs is found by calculating the power load of the combination of load impedance and fault impedance in steps during the fault. The difference between this load and the system power load before the fault means the generators will slow down or speed up under the control of the governors. In most cases, the generators will speed up as the fall in voltage reduces the power of the connected load while the additional power load of the fault is low as it is usually very low power factor. The change in speed that actually occurs depends on the inertia of the machine.

Calculation of Fault Currents

Generator Reactances and Time Constants

The works short circuit test can be analysed to obtain T_{ds}'' , T_{ds}' , X_{d}'' and X_{d}' .

If the machine is also switched onto a low resistance, then values can be obtained for X_{q}'' and T_{qs}'' .

Short circuit and open circuit characteristics

The generator is usually dried out as part of the commissioning procedure. A short circuit of heavy section copper bar is bolted to the generator circuit breaker terminals. The short circuit characteristic is obtained during the dry out and it can be followed by the open circuit characteristic.

Off load tests

With the machine running off load, the effect of a sudden change in excitation can be analysed to obtain values for T_{do}'' and T_{do}' . It may be possible to do this on load to obtain a value for T_{qo}'' .

On load records

With the machine on load, the excitation current can be recorded for various loads and power factors to confirm X_{d} and obtain a value for X_{q} .

Excellent Economics and Business programmes at:



**university of
 groningen**



**“The perfect start
 of a successful,
 international career.”**

CLICK HERE
 to discover why both socially
 and academically the University
 of Groningen is one of the best
 places for a student to be

www.rug.nl/feb/education



Note. Any oscillographs taken of transient conditions should be recorded on an oscilloscope supplied from a different power supply, battery and inverter or a small generator. If the oscilloscope is supplied from the same supply, the trace will disappear off screen due to the system voltage fluctuations that occur in transient conditions.

Machine Inertia

The inertia, H, is measured in kW seconds of kinetic energy at full rated speed per kVA. This can be estimated by plotting the curve of speed against time during a normal start. As the speed approaches full speed, the prime mover power increases till the governor kicks in. Draw the tangent to the curve at the speed corresponding to full load governor droop

Extend this tangent to the full speed line at the top and the axis at the bottom. The value T seconds is the approximate time to gain full speed kinetic energy if the prime mover supplied rated full load power throughout this period. Thus the kinetic energy is approximately T · MW megawatt seconds where MW is the rated full load in megawatts. Hence an approximate value of H can be obtained

$$H = T \cdot MW/MVA$$

$$= T \cdot pf$$

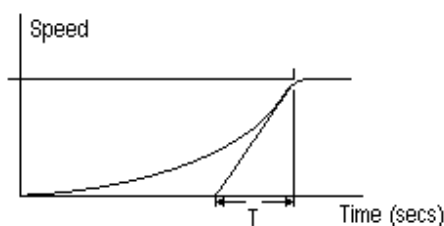

Impedance external to the power station

The impedance of the power system between the power station and the fault largely determines the magnitude of the fault. Power lines and cables have resistance and inductive reactance. Transformers have inductive reactance but negligible resistance.

Resistance of Power Lines and cables

Manufacturer’s figures for the resistance of line conductors are usually available.

In the absence of manufacturer’s figures, the table below gives approximate values for hard drawn copper conductors.

Size mm ²	10	16	35	50	70	95	150
Ohms/km/phase	4.02	1.09	0.596	0.379	0.298	0.181	0.102

Aluminium conductor sizes are usually quoted as equivalent copper size. If the actual size is quoted, multiply the above figures by 1.7

Reactance of Power Lines

Manufacturer's figures are usually available.

The reactance $X = 0.016 \cdot \mu + 0.146 \cdot \text{Log}_{10}(D / r)$ ohms/km

Where μ is permeability, D is conductor spacing and r is conductor radius.

Approximate Reactance of power lines in ohms/phase/km

Size mm ²	10	16	35	50	70	95	150
12 inch spacing	0.34	0.32	0.29	0.28	.28	.27	.25
36 inch spacing	0.41	0.39	0.37	0.35	0.34	0.33	0.32
72 inch spacing	0.45	0.43	0.41	0.40	0.39	0.38	0.36

Reactance of Cables

Manufacturer's figures are usually available.

In the absence of manufacturer's figures, the table below gives the approximate value of the reactance of three core belted cables in ohms/phase/km

Size mm ²	16	35	50	70	95	150	300	500
1100 Volt	0.081	0.073	0.070	0.069	0.066	0.065	0.063	0.062
3.3 kV	0.089	0.078	0.076	0.073	0.070	0.068	0.066	0.065
11 kV	0.108	0.092	0.088	0.084	0.079	0.076	0.072	0.070

Transformer Impedance

Transformer impedance is nearly all reactance and the resistance can be ignored. The transformer nameplate quotes the "Impedance Volts". This is the volt drop due to the impedance on full load expressed as a percentage of the rated voltage.

If the nameplate value is unavailable, approximate figures are;

Transformer Size kVA	100	250	500	1000	2000	5000	10000
Impedance Volts %	3	3.5	4	5	5.5	7.5	10

Auto Transformers

If the voltage ratio is near unity, the primary and the secondary are sometimes different connections to the same winding. Transformers of this type are called Auto Transformers. The impedance volts of an auto transformer are about half the above figures.

Positive, Negative and Zero sequence Impedances

The measured or quoted impedances per phase for non rotating plant can be used for both the positive and the negative sequence impedances. The negative phase sequence impedance is usually quoted by the manufacturer for generators. In the absence of manufacturer's figures, the positive sequence impedance could be used but this could lead to significant errors in the calculated fault current.

Zero Sequence Impedances

The zero sequence impedance may be lower or more usually higher by a factor of two or three. It is best to measure the value by a practical test. Power lines with no earth line or a steel earth line have a higher zero sequence impedance. If the impedance of a power line is significant, always measure the zero sequence resistance and reactance on site.

To measure the zero sequence impedance of the generators and other plant, short circuit all three phases each side of the plant. The short circuit at the remote end is then connected to earth. The impedance is then measured between the near end short circuit and earth. This can be done by using a 20 amp Variac transformer, a Voltmeter, an Ammeter and a Wattmeter. The Variac will need to be supplied from a mobile generator or alternatively through an isolating transformer. If it is connected directly to the mains, the neutral connection to earth will negate the readings.

.....Alcatel-Lucent 

www.alcatel-lucent.com/careers

What if you could build your future and create the future?

One generation's transformation is the next's status quo. In the near future, people may soon think it's strange that devices ever had to be "plugged in." To obtain that status, there needs to be "The Shift".



The Zero sequence impedance/phase Z_0 is then 3 x Volts / Current.

The Zero sequence resistance R_0 is 3 x Watts/(Current)²

The Zero sequence reactance is X_0 is $\sqrt{(Z_0^2 - R_0^2)}$

It may be necessary to correct for the voltage drop across the ammeter and wattmeter current coil or for the current through the voltmeter and wattmeter voltage coil.

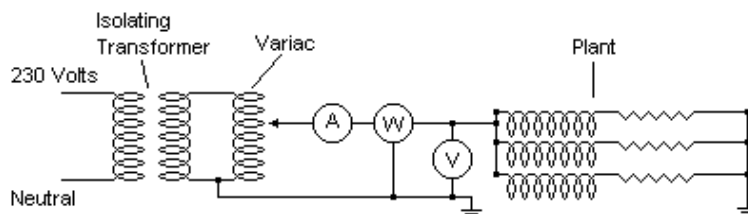

Measurement of Zero Seq Impedance

$$Z_0 = \frac{3 \times \text{Volts}}{\text{Amps}} \quad \text{ohms/phase}$$

$$R_0 = \frac{3 \times \text{Watts}}{\text{Amps}^2}$$

$$X_0 = \sqrt{(Z_0^2 - R_0^2)}$$

Calculation of Fault Currents

Where a power system contains transformers, impedances in series at different voltages cannot be simply added. They must all be converted to the equivalent at the same voltage.

A convenient way to do this is to evaluate each impedance as the per cent volt drop when carrying a “base load”. The base load can be any value but it is common to use 10 MVA.

Impedances to a base 10 MVA

The impedance Z to base 10 MVA is given by;

$$Z = (\% \text{ Plant Impedance}) \cdot 10 / (\text{Plant MVA})$$

$$Z = 1000 \cdot (\text{Impedance in ohms per phase}) / (\text{line kV})^2$$

Impedances in series and at different voltages each expressed to a common base 10 MVA can be added numerically, ie $R = R1 + R2$ and $X = X1 + X2$.

Fault MVA

$$\text{Fault MVA} = [1000 / (\text{total } \% \text{ impedance including the generator subtransient reactance to base 10 MVA})] \text{ MVA}$$

Short Circuit heating

$$\text{Temp rise in degrees C} = [\text{Aps/mm}^2]^2 \times (\text{time in seconds}) / (\text{material factor})$$

where the material factor is about 700 for copper and about 300 for aluminium.

For the permissible short circuit heating, see BS7671 para 434.5.2.

Thus the minimum size of 11kV XPLE cable to carry 250MVA for 2 seconds is about 150mm²

Force between conductors

Mean Force = $2 \times 10^{-4} \times I^2 / S$ Newtons/metre run, where S is the conductor spacing in mm

$$\begin{aligned} \text{Peak Force} &= (1.8 \times \sqrt{2} \times I)^2 \times 2 \times 10^{-4} / S \\ &= 1.30 \times 10^{-3} \times I^2 / S \text{ Newtons/metre run} \end{aligned}$$

Motor Contribution

Add induction motor starting currents to the fault current. This is normal practice, and some standards require it. However, in a fault, the voltage falls and the frequency usually rises. Both cause the motor to take more current rather than generate. In a heavy fault causing near zero voltage, induction motors are likely to generate at slip frequency due to residual magnetism in the rotor. This will "beat" with the fault current and there will be times when the currents are in anti phase.



Maastricht University

Leading in Learning!

Join the best at the Maastricht University School of Business and Economics!

Top master's programmes

- 33rd place Financial Times worldwide ranking: MSc International Business
- 1st place: MSc International Business
- 1st place: MSc Financial Economics
- 2nd place: MSc Management of Learning
- 2nd place: MSc Economics
- 2nd place: MSc Econometrics and Operations Research
- 2nd place: MSc Global Supply Chain Management and Change

Sources: Keuzegids Master ranking 2013; Elsevier 'Beste Studies' ranking 2012; Financial Times Global Masters in Management ranking 2012

Maastricht University is the best specialist university in the Netherlands (Elsevier)

Visit us and find out why we are the best!
Master's Open Day: 22 February 2014

www.mastersopenday.nl



Symmetrical Components

Symmetrical Components

The method of expressing unbalanced currents by symmetrical components is well documented and covered in many textbooks. The following is a summary of what is published elsewhere.

Evaluating Symmetrical Components

The currents in a three phase system can be represented by the sum of three symmetrical three phase currents. The Figure shows the symmetrical components of three very unbalanced currents I_A , I_B and I_C . I_1 , I_2 and I_0 are the positive, negative and zero sequence components. h is the operator that rotates the vector by 120 degrees.

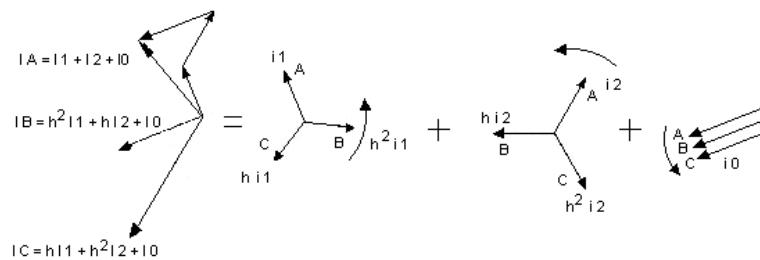

Symmetrical Components

The vector equations are true;

$$I_a = I_0 + I_1 + I_2$$

$$I_b = I_0 + h^2 I_1 + h I_2$$

$$I_c = I_0 + h I_1 + h^2 I_2$$

h is the operator that rotates the vector by 120 degrees.

$$h = -1/2 + j \sqrt{3}/2$$

$$h^2 = -1/2 - j \sqrt{3}/2$$

$$h^3 = 1$$

Also $1 + h + h^2 = 0$

Adding $I_a + I_b + I_c = 3 \times I_0$

$$I_a + h \cdot I_b + h^2 \cdot I_c = 3 \cdot I_1$$

$$I_a + h^2 \cdot I_b + h \cdot I_c = 3 \cdot I_2$$

These equations show that there is always one but only one set of symmetrical components for any given three currents

Impedance drop

Let Z_1 , Z_2 and Z_0 be the impedances per phase of the circuit to the positive, negative and zero sequence components of the current.

Generator emfs are;

$$E_a = E$$

$$E_b = h^2 \cdot E$$

$$E_c = h \cdot E$$

$$V_a = E - I_a \cdot Z$$

$$= E - (I_1 \cdot Z_1 + I_2 \cdot Z_2 + I_0 \cdot Z_0)$$

$$V_b = h^2 \cdot E - (h^2 \cdot I_1 \cdot Z_1 + h \cdot I_2 \cdot Z_2 + I_0 \cdot Z_0)$$

$$V_c = h \cdot E - (h \cdot I_1 \cdot Z_1 + h^2 \cdot I_2 \cdot Z_2 + I_0 \cdot Z_0)$$

Three phase fault (LLL)

$$I_a = I_{\text{fault}}$$

$$I_a + I_b + I_c = 0$$

$$V_a = V_b = V_c = V_{\text{fault}}$$

Substituting in the above equations and simplifying;

$$V_{\text{fault}} = 0, \quad I_1 = I_{\text{fault}}, \quad I_2 = 0 \quad \text{and} \quad I_0 = 0$$

$$I_{\text{fault}} = E / Z_1$$

For fault calculations, put XF and RF equal to the sum of all positive sequence reactances and resistances respectively between the generators and the fault.

Single phase to ground (LG)

$$I_a = I_{\text{fault}}$$

$$V_a = I_b = I_c = 0$$

Substituting and simplifying;

$$I_1 = I_2 = I_0 = I_{\text{fault}} / 3$$

$$I_{\text{fault}} = 3 \cdot E / (Z_1 + Z_2 + Z_0)$$

For fault calculations put XF equal to the sum of all positive and negative and zero sequence reactances between the generators and the fault. Similarly put RF equal to all the positive and negative and zero resistances. The fault current is then three times the value calculated for E / Z .

Line to line (LL)

$$I_a = 0$$

$$I_b = -I_c = I_{\text{fault}}$$

$$V_b = V_c$$

Substituting and simplifying;

$$I_0 = 0$$

$$I_1 = -I_2 = (h - h^2) \cdot I_{\text{f}}/3$$

$$I_{\text{f}} = E \cdot \sqrt{3} / (Z_1 + Z_2)$$

For fault calculations put XF equal to the sum of all positive and negative sequence reactances and RF equal to the sum of positive and negative sequence resistances between the generators and the fault. The fault current is then $\sqrt{3}$ times the value calculated for E / Z .

Line to line and ground fault (LLG)

$$I_a = 0, \quad V_b = V_c = 0$$

Substituting and simplifying;

$$I_1 = E / (Z_1 + Z_0 \cdot Z_2 / (Z_0 + Z_2))$$

$$I_2 = -I_1 \cdot Z_0 / (Z_0 + Z_2)$$

$$I_0 = -I_1 \cdot Z_2 / (Z_0 + Z_2)$$

$$I_b = I_0 + h^2 I_1 + h I_2$$

$$I_c = I_0 + h I_1 + h^2 I_2$$

$$\text{Current to ground} = 3 \cdot I_0$$

For fault calculations, it is best to calculate the symmetrical components and then add them vectorally to obtain I_b and I_c . The current to ground, which will be needed if there is earth fault protection, is three times the zero sequence component.

Using these values for the fault calculations, the positive sequence current and the positive sequence busbar voltage are obtained.

Power in terms of symmetrical components

Power due to I_1 is the sum of the vector dot products;

$$\begin{aligned} W &= E \cdot I_1 + h^2 E \cdot h I_1 + h E \cdot h I_1 \\ &= E \cdot I_1 \cdot \cos(\phi_1) + E \cdot I_1 \cdot \cos(\phi_1) + E \cdot I_1 \cdot \cos(\phi_1) \\ &= \sqrt{3} \cdot (\text{line kV}) \cdot I_1 \cdot \cos(\phi_1) \end{aligned}$$

Power due to I_2 is the sum of the vector dot products;

$$\begin{aligned} W &= E \cdot I_2 + h^2 E \cdot h I_2 + h E \cdot h^2 I_2 \\ &= E \cdot I_2 \cdot \cos(\phi_2) + E \cdot I_2 \cdot \cos(2\pi/3 + \phi_2) + E \cdot I_2 \cdot \cos(2\pi/3 - \phi_2) \\ &= E \cdot I_2 \cdot [\cos(\phi_2) - (1/2) \cdot \cos(\phi_2) - (\sqrt{3}/2) \cdot \sin(\phi_2) - (1/2) \cdot \cos(\phi_2) + (\sqrt{3}/2) \cdot \sin(\phi_2)] \\ &= 0 \end{aligned}$$

Power due to I_0 is the sum of the vector dot products;

$$W = E \cdot I_0 + h^2 E \cdot I_0 + h E \cdot I_0 = 0$$

Thus the total power due to the symmetrical components is;

$$W = \sqrt{3} \cdot (\text{line kV}) \cdot I_1 \cdot \cos(\phi_1)$$

where W is in MW, I_1 is in kiloamps and ϕ_1 is the phase angle of I_1

Currents in the primaries of Delta Star Transformers

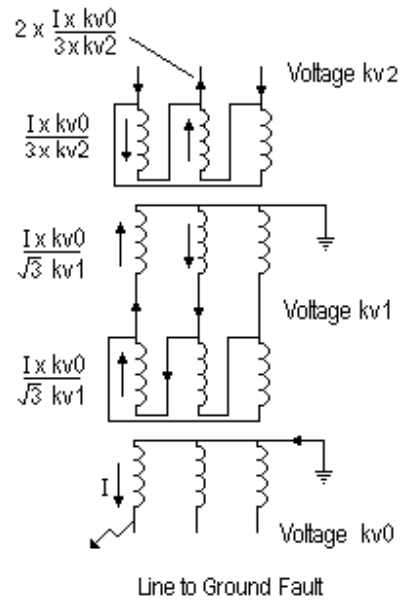

agency.cdg © Photonistop

> Apply now

REDEFINE YOUR FUTURE
AXA GLOBAL GRADUATE PROGRAM 2014

redefining / standards 



Use the turns ratio, not the line voltage ratio to calculate the currents on the primaries of Delta / Star Transformers.

A single line to ground fault of I in one phase of the secondary of the transformer gives rise to a current of $I \cdot kv0/(\sqrt{3} \cdot kv1)$ in two phases of the primary.

A further delta star transformer has a current of $I \cdot kv0/(3 \cdot kv2)$ in two phases of its primary and a current of $2 \cdot I \cdot kv0/(3 \cdot kv2)$ in the third phase.

A Star / Star transformer with a third Delta winding, ie Star / Delta / Star has a current of $(I / 3) \cdot kv0/kv1$ in two phases of the Star primary and a current of $(2 \cdot I / 3) \cdot kv0/kv1$ in the third phase.

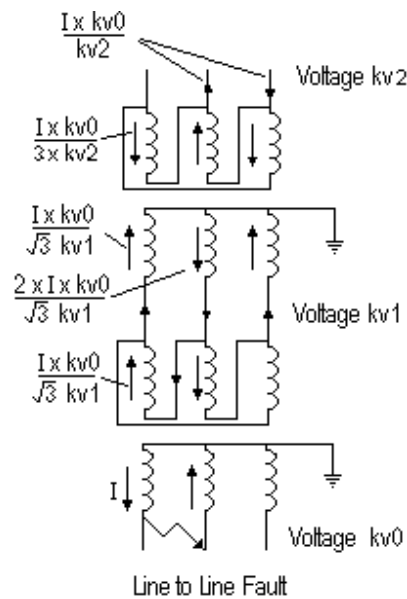

A Line to Line Fault of I at $kv0$ on the secondary side of a delta / star transformer appears as a current of $I \cdot kv0/(\sqrt{3} \cdot kv1)$ on two phases of the primary. The third phase has a current of $2 \cdot I \cdot kv0/(\sqrt{3} \cdot kv1)$.

A further delta / star transformer has a current of $I \cdot kv0 / kv2$ in two phases.

A Star / Delta / Star transformation gives a current of $I \cdot kv0 / kv1$ in two phases of the primary.

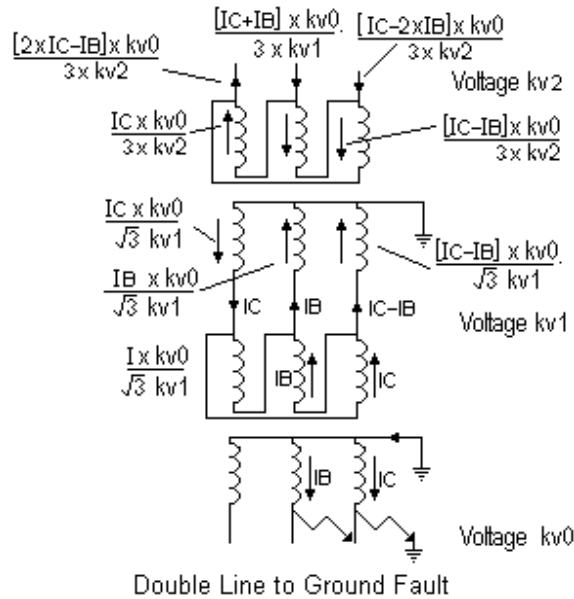

Double Line to ground fault involves the vector sum and difference between the currents on each phase. Thus it is best to keep the fault currents in terms of the symmetrical components until final evaluation.

Combination of Fault current and Load current

LLL and LLLG Faults

The Fault current and Load current are both positive phase sequence only

Hence Total Current = vector sum of Fault current i_{fault} and Load current i_L

$$= \sqrt{[\{i_{fault} \cdot \cos(\phi_F) + i_L \cdot \cos(\phi_L)\}^2 + \{i_{fault} \cdot \sin(\phi_F) + i_L \cdot \sin(\phi_L)\}^2]}$$

where $\phi_F = \arctan(XF/RF)$ and $\phi_L = \arctan(XL/RL)$

LG Fault

The Positive, Negative and Zero phase sequence currents are all in phase on the line with the fault. The Fault current i_{fault} is the sum of these currents.

Hence on the phase with the fault,

Total current = vector sum of i_{fault} and i_L

Hence Total Current

$$= \sqrt{[\{i_{fault} \cdot \cos(\phi_F) + i_L \cdot \cos(\phi_L)\}^2 + \{i_{fault} \cdot \sin(\phi_F) + i_L \cdot \sin(\phi_L)\}^2]}$$

where $\phi_F = \arctan(XF/RF)$ and $\phi_L = \arctan(XL/RL)$

On the other two phases, the fault current is zero.

LL Fault

Zero sequence component = 0

Assume the fault is between phases B and C

On phase A, the Fault current is zero.

On phase A, the Negative sequence component is equal and opposite to the Positive sequence component.

On phase B,

$$\begin{aligned}\text{Fault current} &= h^2 \cdot \text{Positive seq component} + h \cdot \text{Negative seq component} \\ &= (h^2 - h) \cdot \text{Positive seq component}\end{aligned}$$

$$\text{Fault current} = \sqrt{3} \times \text{Positive sequence component of the Fault current}$$

This current lags the voltage E_b by $(\phi_F - \pi/6)$

On phase C,

Fault current is equal and opposite to the Fault current on phase B

It lags the voltage E_c by $(\phi_F + \pi/6)$

Hence the Total current

$$= \sqrt{[\{i_{\text{fault}} \cdot \cos(\phi_T) + i_L \cdot \cos(\phi_L)\}^2 + \{i_{\text{fault}} \cdot \sin(\phi_T) + i_L \cdot \sin(\phi_L)\}^2]}$$

where $\phi_F = \arctan(XF/RF)$ and $\phi_L = \arctan(XL/RL)$

$$\text{On phase B} \quad (\phi_T) = (\phi_F - \pi/6)$$

$$\text{On phase C} \quad (\phi_T) = (\phi_F + \pi/6)$$

LLG Faults

The positive sequence component of the Fault Current can be obtained directly by putting;

$$XF = X_1 + (R_0^2 \cdot X_2 + R_2^2 \cdot X_0 + X_0 \cdot X_2 \cdot (X_0 + X_2)) / ((R_0 + R_2)^2 + (X_0 + X_2)^2)$$

$$RF = R_1 + (R_0 \cdot R_2 \cdot (R_0 + R_2) + R_2 \cdot X_0^2 + R_0 \cdot X_2^2) / ((R_0 + R_2)^2 + (X_0 + X_2)^2)$$



Empowering People. Improving Business.

BI Norwegian Business School is one of Europe's largest business schools welcoming more than 20,000 students. Our programmes provide a stimulating and multi-cultural learning environment with an international outlook ultimately providing students with professional skills to meet the increasing needs of businesses.

BI offers four different two-year, full-time Master of Science (MSc) programmes that are taught entirely in English and have been designed to provide professional skills to meet the increasing need of businesses. The MSc programmes provide a stimulating and multi-cultural learning environment to give you the best platform to launch into your career.

- MSc in Business
- MSc in Financial Economics
- MSc in Strategic Marketing Management
- MSc in Leadership and Organisational Psychology

BI NORWEGIAN BUSINESS SCHOOL

EFMD **EQUIS** ACCREDITED

www.bi.edu/master



This impedance can be combined with the Load Impedance to obtain the equivalent impedance $R + jX$. This enables the Total Positive sequence component to be obtained which can then be separated into the Load Current and Positive Sequence Component of the Fault Current.

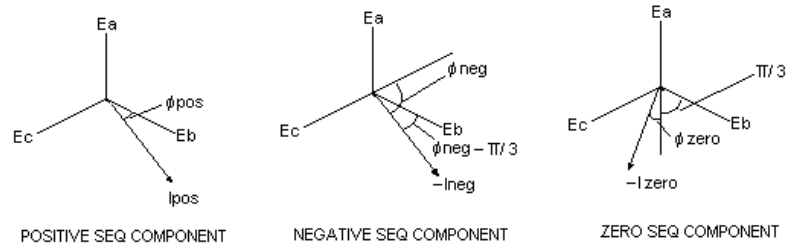

The Negative and Zero components of the Fault Current can then be obtained.

Let Positive Seq Component be I_{pos} at phase angle ϕ_{Pos}
 $\phi_{Pos} = \arctan(XF/RF)$

Let Negative Seq Component be I_{neg} at phase angle ϕ_{Neg} on phase A
 Put $R_3 = R_0 + R_2$ and $X_3 = X_0 + X_2$

$$I_{neg} = -I_{pos} \cdot (R_0 + j X_0) / (R_3 + j X_3)$$

$$= -I_{pos} \cdot [(R_0 \cdot R_3 + X_0 \cdot X_3) + j(R_3 \cdot X_0 - R_0 \cdot X_3)] / (R_3^2 + X_3^2)$$

Hence magnitude of I_{neg} is given by

$$I_{neg} = -I_{pos} \cdot \sqrt{[(R_0 \cdot R_3 + X_0 \cdot X_3)^2 + (R_3 \cdot X_0 - R_0 \cdot X_3)^2]} / (R_3^2 + X_3^2)$$

$$\phi_{Neg} = \phi_F + \arctan[(R_3 \cdot X_0 - R_0 \cdot X_3) / (R_0 \cdot R_3 + X_0 \cdot X_3)]$$

Interchange suffix 2 and 0 to get;

Magnitude of I_{zero} is given by

$$I_{zero} = -I_{pos} \cdot \sqrt{[(R_2 \cdot R_3 + X_2 \cdot X_3)^2 + (R_3 \cdot X_2 - R_2 \cdot X_3)^2]} / (R_3^2 + X_3^2)$$

$$\phi_{Zero} = \phi_F + \arctan[(R_3 \cdot X_2 - R_2 \cdot X_3) / (R_2 \cdot R_3 + X_2 \cdot X_3)]$$

Thus the current in all phases with and without Load Current can be obtained by the vector addition of the relevant currents.

Currents in phase B

Fault Current in phase B =

$$\sqrt{\{I_{pos} \cdot \cos(\phi_{Pos}) + I_{neg} \cdot \cos(\phi_{Neg} - \pi/3) + I_{zero} \cdot \cos(\phi_{Zero} + \pi/3)\}^2 + \{I_{pos} \cdot \sin(\phi_{Pos}) + I_{neg} \cdot \sin(\phi_{Neg} - \pi/3) + I_{zero} \cdot \sin(\phi_{Zero} + \pi/3)\}^2}$$

Similarly, Fault Current in phase C =

$$\sqrt{\{I_{pos} \cdot \cos(\phi_{Pos}) + I_{neg} \cdot \cos(\phi_{Neg} + \pi/3) + I_{zero} \cdot \cos(\phi_{Zero} - \pi/3)\}^2 + \{I_{pos} \cdot \sin(\phi_{Pos}) + I_{neg} \cdot \sin(\phi_{Neg} + \pi/3) + I_{zero} \cdot \sin(\phi_{Zero} - \pi/3)\}^2}$$

$$\text{Current to ground} = 3 \cdot I_{zero}$$

For parts of the network carrying both Load Current and Fault Current, put $I_{pos} = I_{fault}$ but keeping I_{neg} and I_{zero} unchanged as these currents do not flow in the load circuit.

Commissioning Electrical Plant

Works tests

Manufacturers usually carry out tests on their standard range of products. The direct and quadrature axes subtransient, transient reactances and time constants of generators are measured by a short circuit test on a running machine. The exciter characteristics are also measured. Pressure tests and impulse tests may be specified for individual machines in the contract of purchase. Impulse tests are artificial lightning strikes. A bank of capacitors are charged up in parallel then switched into series to give a voltage impulse of up to 3 million volts rising to full value in one microsecond then decaying to 50% value in a further 50 microseconds. The current behaves like a high frequency current and will not go easily round corners. A lightning strike can blast a hole through a masonry abutment rather than follow round it via a lightning conductor of large section copper. The capacitances in the high voltage bushings of a transformer or switchgear play an important part in protecting the equipment in an impulse test. These tests are factory tests and cannot normally be done on site.

To Commission new Electrical Plant, the following tests need to be carried out.

- 1.) Dry out
- 2.) Operation tests
- 3.) Primary Injection
- 4.) Secondary Injection
- 5.) Pressure tests
- 6.) Phase polarity test

Dry Out

All new plant with insulation that can absorb moisture must be dried out before any voltage tests are carried out. Motors can be dried out by applying a low voltage three phase ac supply to the machine. Use a voltage that is too low to rotate the machine but high enough to give a current somewhat lower than full load current. The cooling fan is not supplying cooling air, so the current should not reach the full load value.

At regular intervals of time, the current is switched off and the insulation resistance is measured. As the temperature rises, the insulation resistance falls until a steady temperature is reached. The insulation resistance then rises as the machine dries out. When the machine is dry, the insulation resistance again levels off. Record both the insulation resistance and the temperature. The winding resistance gives a figure for the temperature.

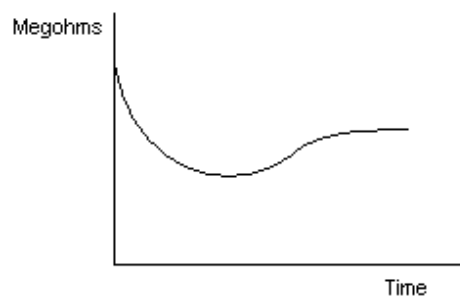

Generators can be dried out by applying a short circuit to earth on all phases and the machine run on hand excitation control. The short circuit connection must be rated for continuous full load current. The normal switchgear earthing gear must on no account be used as it is usually rated for only 30 seconds. A failure of this connection will lead to a catastrophe, the machine voltage will rise rapidly. As the connection melts, a high power fault close to the power station busbars will develop leading to a power station busbar fault.

Some operators remove the generator trip fuses during the dry out. If the machine circuit breaker trips inadvertently, the voltage could rise above the machine rating before the insulation is fully dry and permanently damage the machine.

Dry out may not be possible if the machine is of the brushless excitation design. These machines have an ac exciter on the same shaft as the generator. The exciter field is the stator. The exciter rotor generates ac which is converted to dc by silicon rectifiers at the generator field on the generator rotor. The generator stator is the generator armature. The voltage regulator controls the exciter field and hand control of the exciter may not be possible.

Short circuit and open circuit characteristics can be plotted during and after the dry out if required.

Operation tests

With the switchgear in the racked out position, attach the secondary jump leads. Operate all the closing and tripping controls and trip the switch by all the protection relays.

Primary Injection

Apply a short circuit on the plant and connect a high current low voltage ac supply from a Primary Injection set. Apply the full rated ac current and measure the current in all the CT secondary circuits. Use a milliammeter to display the residual current in earth fault circuits. With all phases short circuited on one side of the plant, apply the primary injection on the other side. Apply the current between the red and yellow phases, repeat between the yellow and blue phases and repeat again between the blue and red phases. Finally apply the injection current between one phase and earth. Record the current in all CT secondary circuits and the CT residual current on each test and check the results are as expected.

Many relays use a metal plug to set the current rating. A useful device is a split plug to fit these relays with a lead to an ammeter connected to each side of the split plug.

Secondary Injection

Apply a low power single phase ac current from secondary injection set to each CT secondary circuit and check the operation of all protection relays and the instrumentation. Time the operation of time lagged relays.

Voltage transformer secondary circuits are also tested at this time. Remove the voltage transformer fuses to prevent any feedback that might make the voltage transformer primary live at full voltage. If a new power station is being commissioned, the synchronising panel will also need to be tested.

Pressure Tests.

The main electrical circuit is tested with a high voltage dc test set. If the neutral is earthed through an impedance, test the red phase with the yellow phase against the blue phase and earth. Repeat the test with the yellow phase and blue phase against the red phase and earth. The test voltages are at prescribed levels, eg use a 30 kV dc test voltage on an 11kV rms line voltage system. **BEWARE A NON LETHAL HIGH VOLTAGE DC TEST SET CHARGES UP THE CAPACITANCE IN HIGH VOLTAGE CABLES TO A LETHAL VALUE.** Discharge the cables after the test, wait a few minutes and discharge them again. Repeat again and again till fully discharged. It can take many minutes to discharge a long cable. Keep the cables earthed while making the connections for the next test.

If the neutral is solidly earthed, the operating voltage to earth is $1/\sqrt{3}$ times the voltage between lines and the pressure tests should take account of this lower voltage.

Phase polarity test

When all the above tests have been successfully done, the plant may be energised for the first time. However if the plant is part of a duplicate supply, the phase connection must be checked before switching the plant into parallel operation. Energise the plant from one end and check the polarity of the voltage transformer secondary with another voltage transformer secondary. Switch off the new plant and energise from the other end and check the voltage transformer polarities again.

If there is no suitable voltage transformer, then a high voltage voltmeter is required to check the polarity of high tension equipment.

Check the direction of rotation of three phase motors.

Automatic Voltage Regulator compounding

When commissioning a generator, the AVR compounding will need to be checked. Incorrect compounding is a common fault on new machines. There is always an earth connection in CT secondary circuits and an earth connection on voltage transformer secondary circuits. The AVR compounding connects a current transformer circuit to a voltage transformer circuit and if these both have an earth connection they may short out the compounding. When the generator supplies a lagging current, the machine reactance lowers the voltage. The AVR compounding must not eliminate this voltage drop or the machines will not run in parallel.

Fault Finding

High impedance faults

A high impedance fault on one phase of a long underground cable or overhead power line can be located by a high voltage bridge.

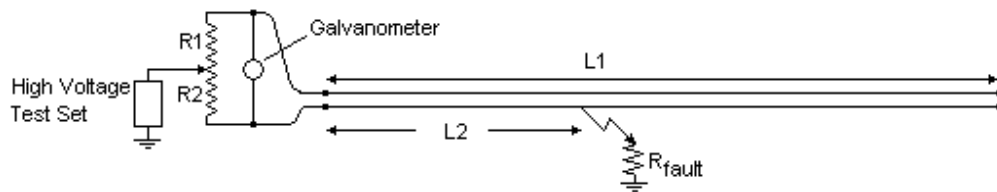

Connect the remote end of the faulty core to a healthy core. Connect the high voltage bridge to this healthy core and the faulty core. Supply the bridge from a high voltage test set and balance the bridge on the slider. Note the readings R_1 and R_2 .

Although the fault resistance may be several thousand ohms and the cable core only a few ohms, the ratio $[L_1 + (L_1 - L_2)]/L_2$ is equal to R_1/R_2

Thus $L_2/L_1 = 2 R_2/(R_1 + R_2)$

It is prudent to keep a record of the exact location of all cable joints on a long underground cable. The fault is usually at a joint unless there is obvious damage above ground.

Need help with your dissertation?

Get in-depth feedback & advice from experts in your topic area. Find out what you can do to improve the quality of your dissertation!

[Get Help Now](#)



Go to www.helpmyassignment.co.uk for more info

 **Helpmyassignment**

Index

<u>Item</u>	<u>Page</u>
Addition of AC quantities	43
AC, Alternating Current	40
AC Bridge Circuits	62-64
AC commutator motor	127
AC machine emf	100, 102-105
Ampere, Amp, I	16
Armature Reaction, AC synch machine	111
Armature Reaction, DC machine	77
Automatic Voltage Regulator, AVR	120
Average Value of AC	40
B, Magnetic Field	15
Bearings	82
Brush drop	95
Brush friction	90
Buchholtz protection	170
Cables	147
Cable and line protection	169
Capacitance, μF	31-33,53
Capacitive load on AC generator	110,112
Circulating current protection	167
Coil span, k_p	101
Commutator	72
Compensating winding, DC machine	77
Contactors	152
Corkscrew Rule	15
Coulomb, q	16
Current Transformers	152
Damping winding	101
DC compound motor	77
DC circuits	36
DC machine emf	74
DC machine with split field	86
DC motor losses	90
DC shunt and series generators	87,88
DC shunt and series motors	75
Deceleration test	94
Delta/Star Transformation	135,204
Direct and quadrature axes	115
Distribution factor, k_d	104
Distribution lines	146
Earth fault protection	155,167

Earthing Electrode	148
Earthing Resistor	149
Eddy currents	50,69,90,147
Electrical degrees	101
Electromagnet	70
Electro Motive force, EMF	24,74,100,104
Energy in a magnetic field	69
Farad, microfarad , μF	31
Faraday's Law	24
Fault MVA	150
Flux, Φ	15
Flux in magnetic circuit	21
Flux in three phase machine	124
Flux in transformers	135
Flux temperature relation	66
Force between conductors	19,200
Form Factor	41
Fractional slots	105
Frequency, f	42
Gauss, G	15
Generator constants	179
Generator protection	168
Gilbert	21
H	15
Harmonics	107-110,145
Heating due to fault current	199
Henry	27
High Rupturing Fuses, HRC Fuses	167
Hopkinson Knapp test for DC machine	92
Hydrogen cooling	101
Hysteresis	66
Impedance, Z	55
Induction meter	163
Induction motor, single phase	131
Induction motor, three phase	127
Instruments, moving coil	159
Instruments, moving iron	160
Instruments, dynamometer	161
Instruments, electrostatic	162
Instruments, induction meter	163
Insulation Class	132
Insulation temperature rating and life	132
Interpoles	78
Iron cored Reactor	52
Kirchoff's Laws	37

Leakage Reactance	111,179
Left Hand Rule	18
Lenz's Law	26
Line impedances	197
Line insulators	146
Line to ground fault	202
Magnetic Circuit	21
Magnetic Field, B	15
Magnetic Flux, Φ	15
Magnetic Properties of materials	65
Magnetizing Force	15-20
Magneto Motive Force, MMF	21
Mercury arc rectifier	140
MMF in three phase machine	124
Motor protection	170,174
Neutral Earth	148
Oersted	15
Ohm, Ω	25
Open Circuit test	113
Overcurrent protection	167
Parallel operation of synchronous machines	118
Peak Factor	41
Permeability, μ	15
Potentiometer	39
Power, AC three phase induction motor	129
Power, DC machine	74
Power, single phase system	44
Power, three phase system	46
Power measurement	46
Power, symmetrical components	203
Power systems	172
Rating of machines	48
Reactance, X	51,53
Rectifier, mercury arc	140
Rectifiers, three phase and single phase	140-145
Rectifier with capacitor	143
Resistance, R	25,26,36,37
Resistance on AC	49-51
Restricted earth fault protection	168
Resonance	56,59
Right Hand Rule	25
Ring Main	175,176
RMS Value of AC	41
Self Inductance, L	27
Short Circuit	178

Short Circuit test	114,178
Slot ripple	108
Speed control of DC motor	83-86
Stability of AC machines	122
Starter for DC motor	82
Surge Diverters	146
Swinburne test for DC motor	90
Switchgear close and trip circuits	154
Switchgear types	150,151
Symmetrical components	201
Synchronising AC machines	120
Synchronising circuits	156,157
Synchronous condenser	124
Synchronous motor	123
Synchronous Reactance, X_d	114
Tesla	15
Thevenin's Theorem	38
Three phase generation	100
Three phase system	45
Three phase fault	177
Torque, AC three phase induction motor	129
Torque, DC machine	74
Transformer cores	135
Transformer flux and emf	135
Transformer losses	137
Transformer magnetising current	137
Transformer protection	169,170
Transformers, delta/star and star/star	135,136
Transformers, unbalanced load	136
Transmission lines	146
Unit pole	15
Vector Diagram AC synchronous machine	117
Vector diagram at fault	181
Vector diag during a fault	184
Vector Representation of AC	43
Voltage transformers	153
Volt, V	24
Ward Leonard set	85
Weber	15
Wheatstone Bridge	39
Winding types	80,81